

BIENNALE MUSICA



La Biennale di Venezia

Arte
Architettura
Cinema
Danza
Musica
Teatro
Archivio Storico

Out of stage

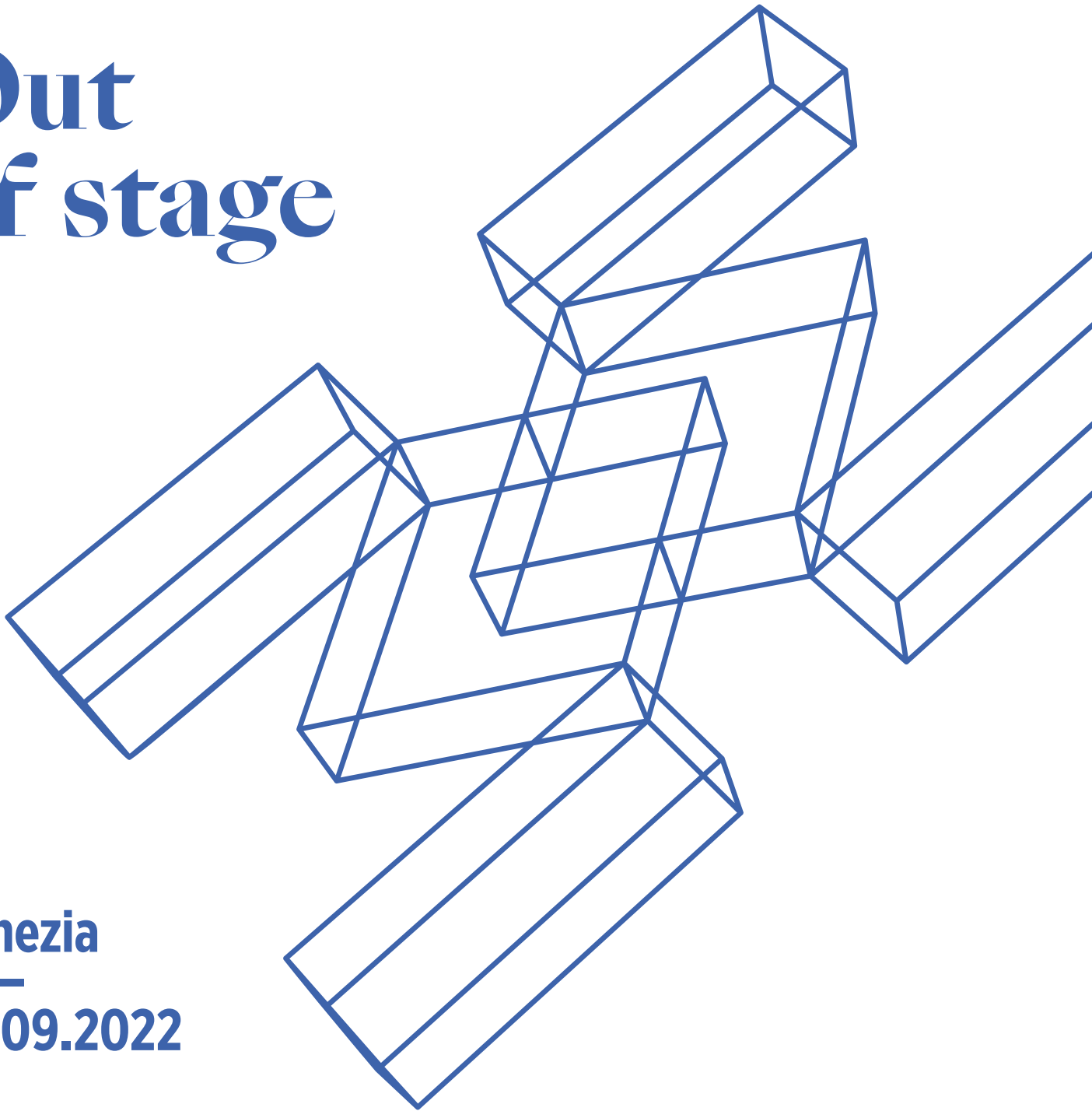

Venezia
14—
25.09.2022

#BiennaleMusica2022

-  La Biennale di Venezia
-  labiennale
-  la_Biennale
-  BiennaleChannel

labiennale.org

La Biennale di Venezia
Ca' Giustinian
San Marco 1364/A

Info:
T. +39 041 5218 828
promozione@labiennale.org



REGIONE DEL VENETO

WEDNESDAY

14.09.22

8.00 PM

Teatro La Fenice

INSTRUMENTAL THEATRE

GIORGIO BATTISTELLI (1953)

JULES VERNE, 1987 (60') ***

Immaginazione in forma di spettacolo

for percussion trio, three voices, trumpet and piano

Libretto by Giorgio Battistelli

Ars Ludi

Antonio Caggiano, Rodolfo Rossi,

Gianluca Ruggeri

Angelo Linzalata, set lighting

Giorgio Battistelli, stage director

La Biennale di Venezia - CIMM,

Centro di Informatica Musicale Multimediale

Thierry Coduys, sound engineer

Production La Biennale di Venezia

In collaboration with

Fondazione Teatro La Fenice

THURSDAY

15.09.22

12.00 PM > 8.00 PM

Arsenale and Forte Marghera - Padiglione 51

VIRTUAL SOUND THEATRE

THIERRY CODUYS (1962)

LE CAS DE L'HIPPOCAMPE, 2022 (12')

VR triptych

Thierry Coduys, concept, composition, sound programming

Agnès de Cayeux, VR design concept

Patricio Di Bacco, development

of 3D unreal engine

Estelle Senay, Martin Saëz,

server Implementation

Vel.Cro, audio engine development

Production, La Biennale di Venezia - CIMM,

Centro Informatico Musicale Multimediale

12.00 PM

Ca' Giustinian - Sala delle Colonne

Award Ceremony

Golden Lion for Lifetime Achievement

GIORGIO BATTISTELLI

12.30

Helga de la Motte in dialogue

with Giorgio Battistelli (30')

5.00 PM > 8.00 PM

Arsenale - Sala d'Armi A

SOUND INSTALLATION

BIENNALE COLLEGE MUSICA 2022

PAUL HAUPTMEIER (1993)

DIAPHANOUS SOUND, 2022 (30') ***

augmented reality sound installation

Production La Biennale di Venezia - CIMM,

Centro di Informatica Musicale Multimediale

8.00 PM

Arsenale - Teatro alle Tese (III)

EXPERIMENTAL MUSIC THEATRE

ONDŘEJ ADÁMEK (1979)

RINO MURAKAMI (1995)

ERIC OBERDORFF

REACHING OUT, 2022 (55') *

MOVING VOICES

ONDŘEJ ADÁMEK

KNOCK EARTH STONE DUST (20')

based on man time stone time for six

singers, two percussionists, two dancers

Lyrics by Sjón (Sigurjón Birgir Sigurðsson)

RINO MURAKAMI

SALMON CROSSING (15')

FOR SIX SINGERS, TWO

PERCUSSIONISTS, TWO DANCERS

Text after *Sake No Uta (Salmon Song)*

By Keiko Oguro

ONDŘEJ ADÁMEK

SCHLAFEN GUT. WARM. (20')

new version for six singers, two

Performers, two dancers

Ondřej Adámek, Eric Oberdorff,

concept and staging

Jean-Gabriel Valot, light design

Marie Hoffmann, production

Ensemble N.E.S.E.V.E.N.

(Never Ending Searching for Exact

Vocal Expression and Nuances)

Olga Siemieńczuk, Shigeko Hata,

Landy Andriamboavonjy, Nicolas Simeha,

Steve Zheng, Paul-Alexandre Dubois,

voice, objects and movement

Compagnie Humaine

Cécile Robin Prévallée, Pierre Theoleyre,

movement and objects

Jeanne Larrouturou, Miguel Angel García

Martín, instruments, objects and movement

Co-Production, La Biennale di Venezia,

GMEM (Groupe de Musique Expérimental

de Marseille) - Centre national de création

musicale, Scène 55 - Mougins / scène con-

ventionnée d'intérêt, C.I.R.M. Centre National

de création musicale (France)

With support by Goethe institut (Germany),

DAAD (German Academic Exchange Servi-

ce), SACEM (France)

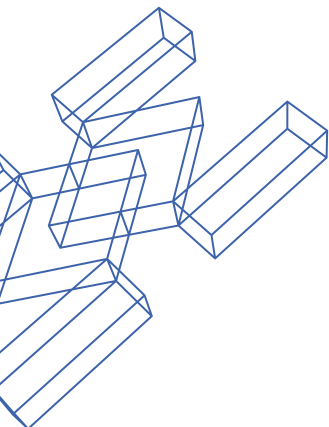

Out of stage

BIENNALE MUSICA 2022

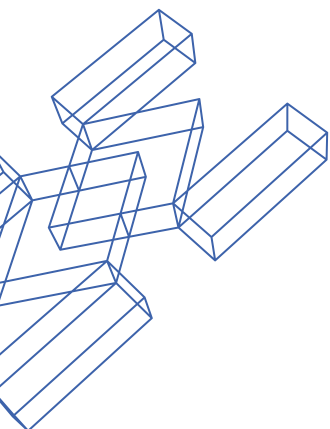

10.30 PM
Ca' Giustinian – Sala delle Colonne
RADIO LIVE
Rai Radio3 – Il teatro di Radio3
BIENNALE COLLEGE MUSICA 2022
GEMMA RAGUÉS (1993)
VERITÀ A VENEZIA, 2022 (50') ***
Gemma Ragués, vocal
and experimental performance
Production La Biennale di Venezia – CIMM,
Centro di Informatica Musicale Multimediale

FRIDAY
16.09.2022

11.00 AM
Ca' Giustinian – Sala delle Colonne
LECTURE
LAURA BERMAN
NEW MUSIC THEATRE, YESTERDAY,
TODAY AND TOMORROW (50')
An aperitif will follow

11.00 AM > 8.00 PM
Arsenale – Sala d'Armi A
SOUND INSTALLATION
BIENNALE COLLEGE MUSICA 2022
PAUL HAUPTMEIER (1993)
DIAPHANOUS SOUND, 2022 (30') ***
augmented reality sound installation
Production La Biennale di Venezia – CIMM,
Centro di Informatica Musicale Multimediale

12.00 PM > 8.00 PM
Arsenale and Forte Marghera - Padiglione 51
VIRTUAL SOUND THEATRE
THIERRY CODUYS (1962)
LE CAS DE L'HIPPOCAMPE, 2022 (12')
VR triptych
Thierry Coduys, concept, composition,
sound programming
Agnès de Cayeux, VR design concept
Patricio Di Bacco, development
of 3D unreal engine
Estelle Senay, Martin Saëz,
server Implementation
Vel.Cro, audio engine development
Production, La Biennale di Venezia - CIMM,
Centro Informatico Musicale Multimediale

7.00 PM
Teatro Piccolo Arsenale
EXPERIMENTAL MUSIC THEATRE
SIMON STEEN-ANDERSEN
**THE RETURN (A.K.A. RUN TIME
ERROR @ VENICE FEAT. MONTEVERDI),**
2022 (80') ***
music theatre for three singers,
baroque ensemble, objects
and video based upon
Il ritorno d'Ulisse in patria
by Claudio Monteverdi
Libretto by Giacomo Badoaro,
with original stage directions,
edits and additions by

by Simon Steen-Andersen
Giulia Bolcato, soprano
Ancio Zorzi Giustiniani, tenor
Davide Giangregorio, bass-baritone
VenEthos Ensemble
Fabiano Martignago,
Anna Chiara Mondin, recorders
Giacomo Catana, Mauro Spinazzè, violins
Francesco Lovato, viola
Leonardo Galligioni, doublebass
Simone Vallerotonda, thiorbo
Alberto Busettini, cembalo (also regal)
Massimo Raccanelli, cello, conductor
Simon Steen-Andersen, concept,
staging, mic- and joystick-performer
Peter Tinning, camera performer
Ellen Rosand, Stefano Nardelli,
interviews
La Biennale di Venezia – CIMM,
Centro di Informatica Musicale Multimediale
Thierry Coduys, ingegnere del suono
Commission La Biennale di Venezia,
funded by Ernst von Siemens Music
Foundation
Production, La Biennale di Venezia
Thanks to VELA S.p.a. and Comune
di Venezia – Venice Film Commission
for collaboration during shooting
in February

9.00 PM
Mestre – Teatro del Parco
EXPERIMENTAL PERFORMANCE
KLEIN
PERFORMANCE, 2022 (30') ***

DANIELE CARCASSI, X. LEE
PARALLAX, 2022 (30') ***
EXPERIMENTAL PERFORMANCE
Production, La Biennale di Venezia – CIMM,
Centro di Informatica Musicale Multimediale
In collaboration with Comune di Venezia /
Cultura Venezia / Teatro del Parco

SATURDAY
17.09.2022

9.00 AM
Ca' Giustinian – Sala delle Colonne
RADIO LIVE
RAI RADIO3 – LEZIONI DI MUSICA
GIOVANNI BIETTI
FRANCESCO CAVALLI, IL GIASONE
Teatro San Cassian, 1649 (30')
A coffee break will follow

11.00 AM > 8.00 PM
Arsenale – Sala d'Armi A
SOUND INSTALLATION
BIENNALE COLLEGE MUSICA 2022
PAUL HAUPTMEIER (1993)
DIAPHANOUS SOUND, 2022 (30') ***
augmented reality sound installation
Production La Biennale di Venezia – CIMM,
Centro di Informatica Musicale Multimediale

12.00 PM > 8.00 PM
Arsenale and Forte Marghera - Padiglione 51
VIRTUAL SOUND THEATRE
THIERRY CODUYS (1962)
LE CAS DE L'HIPPOCAMPE, 2022 (12')
VR triptych
Thierry Coduys, concept, composition,
sound programming
Agnès de Cayeux, VR design concept
Patricio Di Bacco, development
of 3D unreal engine
Estelle Senay, Martin Saëz,
server Implementation
Vel.Cro, audio engine development
Production, La Biennale di Venezia - CIMM,
Centro Informatico Musicale Multimediale

12.00 PM
Ca' Giustinian - Sala delle Colonne
Award Ceremony Silver Lion
ARS LUDI

12.30 PM
Guido Barbieri in dialogue with Ars Ludi (30')

6.00 PM
Teatro Piccolo Arsenale
EXPERIMENTAL MUSIC THEATRE
SIMON STEEN-ANDERSEN (1976)
THE RETURN (A.K.A. RUN TIME
ERROR @ VENICE FEAT.
MONTEVERDI), 2022 (80')

8.00 PM
Fondazione Giorgio Cini - Lo Squero
INSTRUMENTAL THEATRE
BIENNALE COLLEGE MUSICA 2022
Hosted by Tom Service (BBC Radio 3)

FRANÇOIS SARHAN (1972)
SITUATION 4 - VICE VERSA, 2010 (4')
for two performers
Kathryn Vetter, Dafne Paris, performers

GEORGES APERGHIS (1945)
GRAFFITIS, 1981 (20')
for a percussionist
Federico Tramontana, percussion

SIX TOURBILLONS, 1989 (12')
for female voice
Esther-Elisabeth Rispens, soprano

TRYPTIQUE - FIDÉLITÉ (PART III), 1982 (16')
for harp
Dafne Paris, harp

7 CRIMES DE L'AMOUR, 1979 (12')
for soprano, clarinet and percussion
Esther-Elisabeth Rispens, soprano
Kathryn Vetter, clarinet
Federico Tramontana, percussion

CAROLA BAUCKHOLT (1959)
HIRN & EI
(FRAGMENTS OF THE SCORE), 2010 (4')
for four performers
Dafne Paris, Esther-Elisabeth Rispens,
Kathryn Vetter, Federico Tramontana
Production, La Biennale di Venezia

SUNDAY

18.09.22

9.00 AM

Ca' Giustinian - Sala delle Colonne
RADIO LIVE
RAI RADIO3 - LEZIONI DI MUSICA

GIOVANNI BIETTI

ANTONIO VIVALDI, ORLANDO

Teatro dell'Angelo, 1727 (30')
A coffee break will follow

11.00 AM

Conservatorio "Benedetto Marcello" -
Sala dei concerti
LECTURE

PAUL HAUPTMEIER

PERSPECTIVES ON THE USE
OF EXTENDED REALITIES
IN SOUND ART AND COMPOSITION (50')

11.00 PM > 8.00 PM

Arsenale - Sala d'Armi A
SOUND INSTALLATION
BIENNALE COLLEGE MUSICA 2022

PAUL HAUPTMEIER

 (1993)

DIAPHANOUS SOUND, 2022 (30') ***
augmented reality sound installation
Production La Biennale di Venezia - CIMM,
Centro di Informatica Musicale Multimediale

12.00 PM > 8.00 PM

Arsenale and Forte Marghera - Padiglione 51
VIRTUAL SOUND THEATRE

THIERRY CODUYS

 (1962)

LE CAS DE L'HIPPOCAMPE, 2022 (12')
VR triptych

Thierry Coduys, concept, composition,
sound programming

Agnès de Cayeux, VR design concept
Patricio Di Bacco, development
of 3D unreal engine

Estelle Senay, Martin Saëz,
server Implementation

Vel.Cro, audio engine development
Production, La Biennale di Venezia - CIMM,
Centro Informatico Musicale Multimediale

16.00

Biblioteca Marciana - Salone Sansoviniano
PERFORMATIVE LECTURE

AD IMITATIONE DELLE PASSIONI (30')

"Canto" and "declamato" between Florence
and Venice in early seventeenth Century
Texts by Claudio Monteverdi
and Giulio Caccini

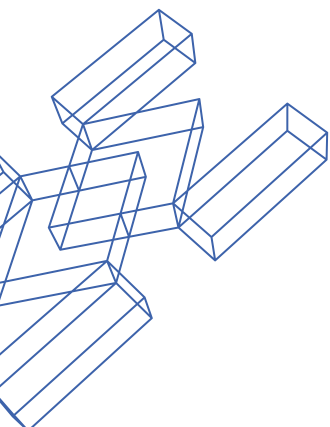

Paolo Da Col, lecture
and vocal performance
INSTRUMENTAL THEATRE
MEHDI JALALI (1980)
UNFOLDING, 2022 (30') ***
praying ritual for solo tanbur
Improvisation on maqams by
Khan-Amiri, Sahari, Chupi-Razbaari,
Savar-Savar and Jelo-Shahi
RAGHS-E-SAMA
from KHAT-E-SEVOM, 2016
Mehdi Jalali, tanbur

8.00 PM
Arsenale - Tese dei Soppalchi
INSTRUMENTAL THEATRE
Hosted by Tom service (BBC Radio 3)
GIORGIO BATTISTELLI (1953)
ORAZI E CURIAZI, 1996 (13')
for two percussionists
Ars Ludi
Antonio Caggiano, Gianluca Ruggeri
MAURICIO KAGEL (1931-2008)
DRESSUR, 1977 (30')
percussion trio for wooden instruments
Ars Ludi
Antonio Caggiano, Rodolfo Rossi,
Gianluca Ruggeri

MONDAY
19.09.2022
11.00 AM
Conservatorio "Benedetto Marcello"
Sala dei concerti
LECTURE
ELLEN ROSAND
THE FIRST EXPERIMENTAL
MUSIC THEATRE:
VENETIAN OPERA (50')

11.00 PM > 7.00 PM
Arsenale - Sala d'Armi A
SOUND INSTALLATION
BIENNALE COLLEGE MUSICA 2022
PAUL HAUPTMEIER (1993)
DIAPHANOUS SOUND, 2022 (30') ***
augmented reality sound installation
Production La Biennale di Venezia - CIMM,
Centro di Informatica Musicale Multimediale

12.00 PM > 8.00 PM
Arsenale and Forte Marghera - Padiglione 51
VIRTUAL SOUND THEATRE
THIERRY CODUYS (1962)
LE CAS DE L'HIPPOCAMPE, 2022 (12')
VR triptych
Thierry Coduys, concept, composition,
sound programming
Agnès de Cayeux, VR design concept
Patricio Di Bacco, development
of 3D unreal engine
Estelle Senay, Martin Saëz,
server Implementation

Vel.Cro, audio engine development
Production, La Biennale di Venezia - CIMM,
Centro Informativo Musicale Multimediale

8.00 PM
Teatro Goldoni
EXPERIMENTAL MUSIC THEATRE
MICHEL VAN DER AA
THE BOOK OF WATER, 2022 (70') ***
music theatre for actor, string quartet
and film based upon *Der Mensch
erscheint im Holozän* by Max Frisch
adapted by Michel van der Aa
Samuel West, narrator, geiser
Timothy West, geiser (film)
Mary Bevan, Corinne (soprano, film)
Ensemble Modern String Quartet
Jagdish Mistry, Giorgos Panagiotidis, violins
Megumi Kasakawa, viola
Eva Böcker, cello
Michael van der Aa, composition,
stage director and script
Madelon Kooijman, dramaturgy
Bart van den Heuvel, light design
Djoere de Jong, production
Paul Jeukendrup, sound design
Judith de Zwart, costume design
Joost Rietdijk nsc, director of photography
Arjen Oosterbaan, Eastbound Films,
executive producer film
Djoere de Jong, ProductieCollectief,
production manager
Siemen van der Werf,
technical director
Martijn van Nunen, stage manager
Fergus McAlpine, play-out operator
Douwe Bulten, light operator
Tomas Valečka, sound operator
Commission La Biennale di Venezia, Ensemble Modern, Muziekgebouw Amsterdam,
Amsterdam Sinfonietta, November Music,
Philharmonie Cologne
With financial support of Ammodo, Prins
Bernhard Cultuurfonds, Cultuurfonds Bank
Nederlandse Gemeenten,
Ernst Von Siemens Music Foundation,
Stiching Reinbert de Leeuw,
Société Gavignières
Foundation doubleA is supported by Performing Arts Fund NL

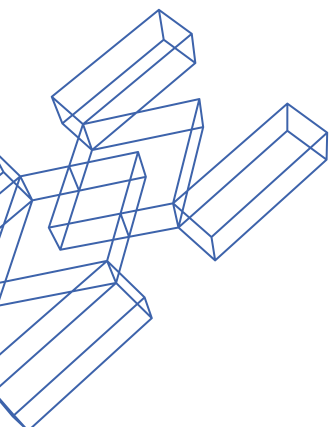

Out of stage

BIENNALE MUSICA 2022

TUESDAY

20.09.2022

11.00 AM

Conservatorio "Benedetto Marcello"
Sala dei concerti
LECTURE

MICHEL VAN DER AA (50')

11.00 PM > 7.00 PM

Arsenale - Sala d'Armi A
SOUND INSTALLATION
BIENNALE COLLEGE MUSICA 2022
PAUL HAUPTMEIER (1993)
DIAPHANOUS SOUND, 2022 (30') ***
augmented reality sound installation
Production La Biennale di Venezia - CIMM,
Centro di Informatica Musicale Multimediale

12.00 PM > 8.00 PM

Arsenale and Forte Marghera - Padiglione 51
VIRTUAL SOUND THEATRE

THIERRY CODUYS (1962)

LE CAS DE L'HIPPOCAMPE, 2022 (12')

VR triptych

Thierry Coduys, concept, composition,
sound programming
Agnès de Cayeux, VR design concept
Patricio Di Bacco, development
of 3D unreal engine

Estelle Senay, Martin Saëz,
server Implementation

Vel.Cro, audio engine development
Production, La Biennale di Venezia - CIMM,
Centro Informatico Musicale Multimediale

6.00 PM

Ca' Giustinian - Sala delle Colonne
CHORAL MUSIC THEATRE
NATIVE AMERICAN INSPIRATIONS ***
a music drama in voice

BRENT MICHAEL DAVIDS (1959)

MOHICAN SOUP, 1997

NIGHT CHANT, 1996

CITY OF WATER, 2022

Commission Shenandoah Conservatory

RUSSELL WALLACE (1965)

ST'AT'IMC

JOURNEY, 2002

LOUIS BALLARD (1931-2007)

QUAPAW/CHEROKEE

MOHAVE BIRD DANCE SONGS, ARR. 2003

DAWN Ierihokwats AVERY

MOHAWK/KANIËNKÉHA (1961)

TEIONKHIYÀ:TATON, 2022

JENNIFER STEVENS (1972)

ONEIDA

BEGINNING OF TIME, 2022

Vocal Ensemble Students
Shenandoah Conservatory &
Shenandoah University
Austin Thorpe, conductor

Ella Marchment, director

Co-production La Biennale di Venezia,
Sala 1 - Centro Internazionale d'Arte
Contemporanea, Shenandoah Conservatory

9.00 PM

Mestre - Teatro del Parco
EXPERIMENTAL PERFORMANCE

YVETTE JANINE JACKSON (1973)

LEFT BEHIND, 2022 (60') ***

a radio opera

Radio Opera Workshop Ensemble
Malesha Jessie Taylor, voice

Joy Guidry, bassoon

Amy Cimini, viola

Judith Hamann, cello

Tommy Babin, double bass

Yvette Janine Jackson, electronics

In collaboration with Comune di Venezia /
Cultura Venezia / Teatro del Parco

WEDNESDAY

21.09.2022

11.00 AM

Conservatorio "Benedetto Marcello"
Sala dei concerti
LECTURE

YVETTE JANINE JACKSON (50')

11.00 PM > 7.00 PM

Arsenale - Sala d'Armi A
SOUND INSTALLATION
BIENNALE COLLEGE MUSICA 2022

PAUL HAUPTMEIER (1993)

DIAPHANOUS SOUND, 2022 (30') ***

augmented reality sound installation

Production La Biennale di Venezia - CIMM,
Centro di Informatica Musicale Multimediale

12.00 PM > 8.00 PM

Arsenale and Forte Marghera - Padiglione 51
VIRTUAL SOUND THEATRE

THIERRY CODUYS (1962)

LE CAS DE L'HIPPOCAMPE, 2022 (12')

VR triptych

Thierry Coduys, concept, composition,
sound programming

Agnès de Cayeux, VR design concept

Patricio Di Bacco, development

of 3D unreal engine

Estelle Senay, Martin Saëz,

server Implementation

Vel.Cro, audio engine development

Production, La Biennale di Venezia - CIMM,
Centro Informatico Musicale Multimediale

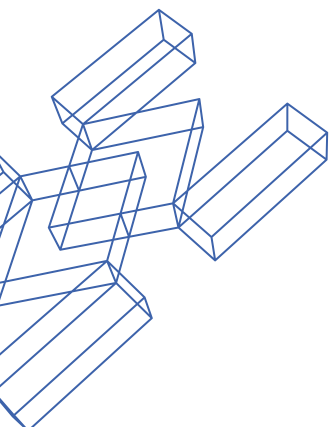

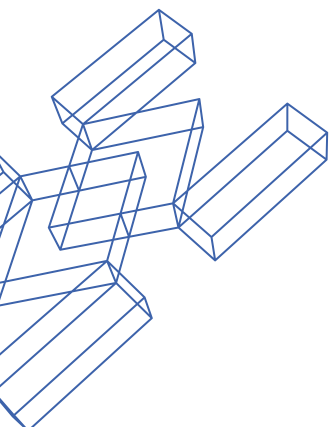

9.00 PM
 Basilica di San Marco
SACRED REPRESENTATION
HELENA TULVE (1972)
 VISIONS, 2022 (50') ***
 for vocal ensemble, "cori spezzati"
 and multiple instrumental ensembles
 Text by Helena Tulve
 After fragments of sacred representation
 found by Giulio Cattin in Santa
 Maria della Fava and the Gospel
 of Mary Magdalene
 Vox Clamantis
 Jaan-Eik Tulve, conductor
 Cappella Marciana
 Marco Gemmani, conductor
 Marco Ambrosini, Angela Ambrosini,
 nyckelharpa
 Anna-Liisa Eller, kannel, percussion
 Ensemble Barocco del Conservatorio
 "Benedetto Marcello" di Venezia
 Francesco Erle, conductor
 Marius Peterson, stage director
 Commission La Biennale di Venezia,
 funded by Ernst von Siemens Music
 Foundation
 Production La Biennale di Venezia
 In collaboration with Basilica
 e Procuratoria di San Marco

THURSDAY
22.09.2022
 10.00 AM > 12.00 PM
 Fondazione Ugo e Olga Levi -
 Sala Biblioteca
ROUND TABLE
GIULIO CATTIN'S CRITICAL
RECONSTRUCTION OF THE FOURTEEN-
TH-CENTURY LITURGICAL DRAMAS
IN SANTA MARIA DELLA FAVA
AND HELENA TULVE'S NEW TREATMENT
OF THE COMPOSITION
 Helena Tulve
 (Estonian Academy of Music and Theatre),
 Roberto Calabretto (Fondazione Ugo
 e Olga Levi, Università di Udine),
 Antonio Lovato (Università di Padova),
 Francesco Erle (Conservatorio
 "Benedetto Marcello" di Venezia)
 in collaboration with
 Fondazione Ugo e Olga Levi

11.00 PM > 8.00 PM
 Arsenale - Sala d'Armi A
SOUND INSTALLATION
BIENNALE COLLEGE MUSICA 2022
PAUL HAUPTMEIER (1993)
 DIAPHANOUS SOUND, 2022 (30') ***
 augmented reality sound installation
 Production La Biennale di Venezia - CIMM,
 Centro di Informatica Musicale Multimediale

12.00 PM > 8.00 PM
 Arsenale and Forte Marghera - Padiglione 51
VIRTUAL SOUND THEATRE
THIERRY CODUYS (1962)
 LE CAS DE L'HIPPOCAMPE, 2022 (12')
 VR triptych
 Thierry Coduys, concept, composition,
 sound programming
 Agnès de Cayeux, VR design concept
 Patricio Di Bacco, development
 of 3D unreal engine
 Estelle Senay, Martin Saëz,
 server Implementation
 Vel.Cro, audio engine development
 Production, La Biennale di Venezia - CIMM,
 Centro Informatico Musicale Multimediale

4.00, 6.00 PM
 Arsenale - Sala d'Armi E
PERFORMATIVE SOUND INSTALLATION
ALEXANDER SCHUBERT (1979)
 SLEEP LABORATORY, 2022 (50') *
 performative installation for
 musicians/performers and VR/360 Video
 United Instruments of Lucilin
 Sophie Deshayes, flute
 Winnie Cheng, violin
 Danielle Hennicot, viola
 Ingrid Schoenlaub, cello
 Pascal Meyer, piano
 Guy Frisch, percussion
WE ARE VISUAL
 Marc Einsiedel, Felix Jung, set
 Multimedia Kontor Hamburg (MMKH)
 Leonhard Onken Menke, Sebastian Olariu,
 VR/360 Video
 Tobias Johannes Pfeil, co-development
 and artistic collaboration
 Felina Levits, costumes
 Jonathan Harth, scientific adviser
 Alexander Schubert, concept, stage director
 Co-production La Biennale di Venezia,
 ACHT BRÜCKEN-Musik für
 Köln, Philharmonie Luxemburg (rainy days
 festival), United Instruments of Lucilin

8.00 PM
 Arsenale – Teatro alle Tese (II)
 EXPERIMENTAL MUSIC THEATRE
PAOLO BUONVINO (1968)
 CIATU, 2022 (50') ***
 for vocalists, disklaviers, ensemble,
 recorded voices and live electronics
 Text by Paolo Buonvino
 based on literary and documentary frag-
 ments about the concept of breath in Sicily
 Paolo Buonvino, piano and live electronics
 Rossella Ruini, Badara Seck,
 Faisal Taher, vocalists
 Pasquale Laino, wind instruments
 and live electronics
 Seby Burgio, keyboard and live electronics
 PMCE - Parco della Musica
 Contemporanea Ensemble
 Manuel Zurria, flutes
 Paolo Ravaglia, ethnic flutes and clarinets
 Flavio Tanzi, percussion
 Francesco Peverini, violin I
 Filippo Fattorini, violin II
 Luca Sanzò, viola
 Anna Armatys, cello
 Massimo Ceccarelli, doublebass
 Tommaso Cancellieri, sound design
 Fabio Venturi, audio project
 Tonino Battista, conductor
 2 Yamaha Disklavier D U1 EN verticals
 1 Yamaha C7X EN Disklavier
 Thierry Coduys, Paolo Buonvino, sound
 design and live electronics
 Silvia Barbera, musical assistant
 Irma Blank, art installation
 Maria Grazia Chiuri per / for DIOR, costumes
 Antonello Pocetti, direction
 Marco Lucarelli, light project
 Maria Alicata, curator visual project
 production of the Irma Blank art
 installation by Bureau Betak for DIOR
 Madre, video animation
 Commission La Biennale di Venezia
 Production La Biennale di Venezia
 Thanks to House of DIOR for the production
 of the costumes
 Thanks to P420, Bologna for Irma Blank's
 artwork

FRIDAY
 23.09.2022

11.00 AM
 Conservatorio “Benedetto Marcello”
 Sala dei concerti
 LECTURE
ONDŘEJ ADÁMEK (50')

11.00 PM > 8.00 PM
 Arsenale – Sala d'Armi A
 SOUND INSTALLATION
 BIENNALE COLLEGE MUSICA 2022
PAUL HAUPTMEIER (1993)
 DIAPHANOUS SOUND, 2022 (30') ***
 augmented reality sound installation
 Production La Biennale di Venezia – CIMM,
 Centro di Informatica Musicale Multimediale

12.00 PM > 8.00 PM
 Arsenale and Forte Marghera - Padiglione 51
 VIRTUAL SOUND THEATRE
THIERRY CODUYS (1962)
 LE CAS DE L'HIPPOCAMPE, 2022 (12')
 VR triptych
 Thierry Coduys, concept, composition,
 sound programming
 Agnès de Cayeux, VR design concept
 Patricio Di Bacco, development
 of 3D unreal engine
 Estelle Senay, Martin Saëz,
 server Implementation
 Vel.Cro, audio engine development
 Production, La Biennale di Venezia - CIMM,
 Centro Informatico Musicale Multimediale

12.00, 2.00, 4.00, 6.00 PM
 Arsenale – Sala d'Armi E
 PERFORMATIVE SOUND INSTALLATION
ALEXANDER SCHUBERT (1979)
 SLEEP LABORATORY, 2022 (50') *
 performative installation for
 musicians/performers and VR/360 Video
 United Instruments of Lucilin
 Sophie Deshayes, flute
 Winnie Cheng, violin
 Danielle Hennicot, viola
 Ingrid Schoenlaub, cello
 Pascal Meyer, piano
 Guy Frisch, percussion
 WE ARE VISUAL
 Marc Einsiedel, Felix Jung, set
 Multimedia Kontor Hamburg (MMKH)
 Leonhard Onken Menke, Sebastian Olariu,
 VR/360 Video
 Tobias Johannes Pfeil, co-development
 and artistic collaboration
 Felina Levits, costumes
 Jonathan Harth, scientific adviser
 Alexander Schubert, concept, stage director
 Co-production La Biennale di Venezia,
 ACHT BRÜCKEN-Musik für
 Köln, Philharmonie Luxemburg (rainy days
 festival), United Instruments of Lucilin

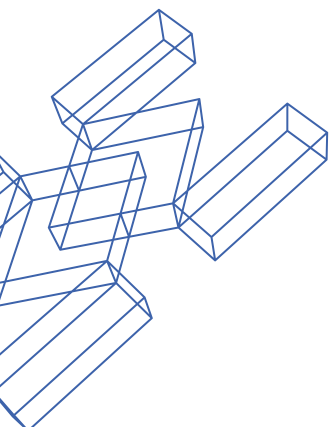

Out of stage

BIENNALE MUSICA 2022

4.00, 4.30, 5.00, 5.30 PM
Arsenale – Teatro alle Tese (II)
SOUND INSTALLATION
PAOLO BUONVINO
ÇIATU, 2022 (30') ***
Paolo Buonvino, concept and composition
Irma Blank, art installation
Marco Lucarelli, light
Antonello Pocetti, mise en espace
Fabio Venturi, audio project
La Biennale di Venezia – CIMM, Centro di Informatica Musicale Multimediale
Thierry Coduys, sound diffusion
production of the Irma Blank art installation by Bureau Betak for DIOR
Madre, video animation
Maria Alicata, curator visual project
Commission La Biennale di Venezia
Production La Biennale di Venezia
Thanks to House of DIOR
for the production of the costumes
Thanks to P420, Bologna
for Irma Blank's artwork

8.00 PM
Arsenale – Tese dei Soppalchi
EXPERIMENTAL PERFORMANCE
BIENNALE COLLEGE MUSICA 2022
TANIA CORTÉS (1993)
R I Z O M A, 2022 (30') ***
for electronics and video
Tania Cortés, performer
JACOPO CENNI
HUNT, 2022 (30') ***
sound theatre for electronics
and incandescent light bulbs
Jacopo Cenni, performer
Production La Biennale di Venezia – CIMM,
Centro di Informatica Musicale Multimediale

SATURDAY
24.09.2022
9.00 AM
Ca' Giustinian – Sala delle Colonne
RADIO LIVE
RAI RADIO3 – LEZIONI DI MUSICA
GIOVANNI BIETTI
BRUNO MADERNA, HYPERION
Teatro La Fenice, 1964 (30')
A coffee break will follow

11.00 AM
Conservatorio "Benedetto Marcello"
Sala dei concerti
LECTURE
PAOLO BUONVINO (50')

11.00 PM > 8.00 PM
Arsenale – Sala d'Armi A
SOUND INSTALLATION
BIENNALE COLLEGE MUSICA 2022
PAUL HAUPTMEIER (1993)
DIAPHANOUS SOUND, 2022 (30') ***
augmented reality sound installation
Production La Biennale di Venezia – CIMM,
Centro di Informatica Musicale Multimediale

12.00 PM > 8.00 PM
Arsenale and Forte Marghera - Padiglione 51
VIRTUAL SOUND THEATRE
THIERRY CODUYS (1962)
LE CAS DE L'HIPPOCAMPE, 2022 (12')
VR triptych
Thierry Coduys, concept, composition,
sound programming
Agnès de Cayeux, VR design concept
Patricio Di Bacco, development
of 3D unreal engine
Estelle Senay, Martin Saëz,
server Implementation
Vel.Cro, audio engine development
Production, La Biennale di Venezia - CIMM,
Centro Informatico Musicale Multimediale

12.00, 2.00, 4.00, 6.00 PM
Arsenale – Sala d'Armi E
PERFORMATIVE SOUND INSTALLATION
ALEXANDER SCHUBERT (1979)
SLEEP LABORATORY, 2022 (50') *
performative installation for
musicians/performers and VR/360 Video
United Instruments of Lucilin
Sophie Deshayes, flute
Winnie Cheng, violin
Danielle Hennicot, viola
Ingrid Schoenlaub, cello
Pascal Meyer, piano
Guy Frisch, percussion
WE ARE VISUAL
Marc Einsiedel, Felix Jung, set
Multimedia Kontor Hamburg (MMKH)
Leonhard Onken Menke, Sebastian Olariu,
VR/360 Video
Tobias Johannes Pfeil, co-development
and artistic collaboration
Felina Levits, costumes
Jonathan Harth, scientific adviser
Alexander Schubert, concept, stage director
Co-production La Biennale di Venezia,
ACHT BRÜCKEN-Musik für
Köln, Philharmonie Luxemburg (rainy days
festival), United Instruments of Lucilin

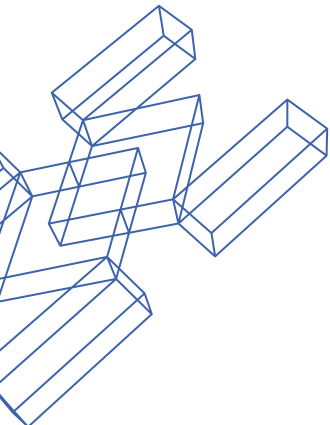

4.00, 4.30, 5.00, 5.30 PM
Arsenale – Teatro alle Tese (II)
SOUND INSTALLATION
PAOLO BUONVINO
ÇIATU, 2022 (30') ***
Paolo Buonvino, concept and composition
Irma Blank, art installation
Marco Lucarelli, light
Antonello Pocetti, mise en espace
Fabio Venturi, audio project
La Biennale di Venezia – CIMM, Centro di Informatica Musicale Multimediale
Thierry Coduys, sound diffusion
production of the Irma Blank art installation by Bureau Betak for DIOR
Madre, video animation
Maria Alicata, curator visual project
Commission La Biennale di Venezia
Production La Biennale di Venezia
Thanks to House of DIOR
for the production of the costumes
Thanks to P420, Bologna
for Irma Blank's artwork

6.00 PM
Teatro Piccolo Arsenale
EXPERIMENTAL MUSIC THEATRE
BIENNALE COLLEGE MUSICA
COMPOSER
TIMOTHY CAPE (1991)
STILL DROWSY, 2022 (30') ***
performative music theatre for voice,
percussion trio and sound diffusion
Text collated by Timothy Cape
Esther-Elisabeth Rispens, soprano
Ars Ludi
Antonio Caggiano, Rodolfo Rossi,
Gianluca Ruggeri

DANIIL POSAZHENNIKOV
RELICT, 2022 (35') ***
linguistic mantram for voice,
percussion trio, video and electronics
Libretto by Egor Zaytsev
Esther-Elisabeth Rispens, soprano
Ars Ludi
Antonio Caggiano, Rodolfo Rossi,
Gianluca Ruggeri
Daniil Posazhennikov, stage director
Egor Zaytsev, dramaturgy
Production La Biennale di Venezia – CIMM,
Centro di Informatica Musicale Multimediale

9.00 PM
Scuola Grande di San Rocco
MADRIGALE RAPPRESENTATIVO
ANNELIES VAN PARYS (1975)
NOTWEHR, 2022 (50') ***
for two singers, vocal and instrumental
ensemble based upon *Barca di Venetia
per Padova - Dilettevoli Madrigali à cinque
Voci* by Adriano Banchieri, 1605-1623
Libretto by Gaea Schoeters
after Adriano Banchieri
Johanna Zimmer, soprano
Els Mondelaers, mezzo-soprano
VENETIAETERNA vocal ensemble
Silvia Porcellini, soprano
Elisabetta Cuman, mezzo-soprano
Miranda Ying Quan, contralto
Giacomo Schiavo, tenor
Francisco Augusto Bois, bass
Francesco Erle, conductor
HERMESensemble
Karin de Fleyt, flute
Stijn Saveniers, cello
Bram Fournier, trombone
Gaetan La Mela, percussion
Sjaron Minailo, mise en scène
Music Published / Licensed by: © Deuss
Music, The Hague www.deussmusic.com
Commission La Biennale di Venezia
Co-production La Biennale di Venezia,
Studio Minailo, HERMESensemble,
Muziektheater Transparan
With support of the Flemish Government

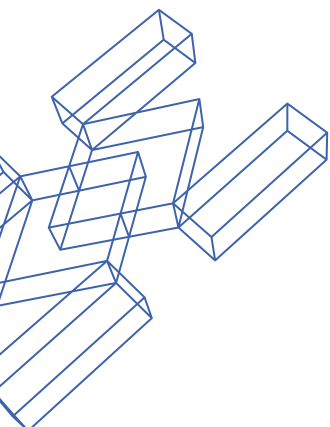

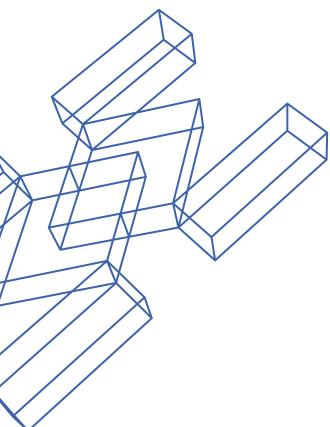

SUNDAY
25.09.2022
9.00 AM

Ca' Giustinian – Sala delle Colonne
RADIO LIVE
RAI RADIO3 – LEZIONI DI MUSICA
GIOVANNI BIETTI
LUIGI NONO, INTOLLERANZA
Teatro La Fenice, 1961 (30')
A coffee break will follow

11.00 AM
Ca' Giustinian – Sala delle Colonne
Award Ceremony of the Jury Prize of
Students from Italian Conservatories (30')
Guido Barbieri, Coordinator of the Jury

11.00 PM > 8.00 PM
Arsenale – Sala d'Armi A
SOUND INSTALLATION
BIENNALE COLLEGE MUSICA 2022
PAUL HAUPTMEIER (1993)
DIAPHANOUS SOUND, 2022 (30') ***
augmented reality sound installation
Production La Biennale di Venezia – CIMM,
Centro di Informatica Musicale Multimediale

12.00 PM > 8.00 PM
Arsenale and Forte Marghera - Padiglione 51
VIRTUAL SOUND THEATRE
THIERRY CODUYS (1962)
LE CAS DE L'HIPPOCAMPE, 2022 (12')
VR triptych
Thierry Coduys, concept, composition,
sound programming
Agnès de Cayeux, VR design concept
Patricio Di Bacco, development
of 3D unreal engine
Estelle Senay, Martin Saëz,
server implementation
Vel.Cro, audio engine development
Production, La Biennale di Venezia - CIMM,
Centro Informatico Musicale Multimediale

12.00, 2.00, 4.00, 6.00 PM
Arsenale – Sala d'Armi E
PERFORMATIVE SOUND INSTALLATION
ALEXANDER SCHUBERT (1979)
SLEEP LABORATORY, 2022 (50') *
performative installation for
musicians/performers and VR/360 Video
United Instruments of Lucilin
Sophie Deshayes, flute
Winnie Cheng, violin
Danielle Hennicot, viola
Ingrid Schoenlaub, cello
Pascal Meyer, piano
Guy Frisch, percussion
WE ARE VISUAL
Marc Einsiedel, Felix Jung, set
Multimedia Kontor Hamburg (MMKH)
Leonhard Onken Menke, Sebastian Olariu,

VR/360 Video
Tobias Johannes Pfeil, co-development
and artistic collaboration
Felina Levits, costumes
Jonathan Harth, scientific adviser
Alexander Schubert, concept, stage director
Co-production La Biennale di Venezia,
ACHT BRÜCKEN-Musik für
Köln, Philharmonie Luxemburg (rainy days
festival), United Instruments of Lucilin

2.00 > 4.00 PM
Fondazione Giorgio Cini – Sala Barbantini
ROUND TABLE
MUSIC THEATRE TODAY.
VOICES, ACTIONS, TECHNOLOGIES
Gianmario Borio (Fondazione Giorgio Cini,
Università di Pavia),
Vincenzina Caterina Ottomano
(Università Ca' Foscari di Venezia)
Participants:
Robert Adlington
(University of Huddersfield),
Susanne Kogler (Universität Graz),
Giordano Ferrari (Université Paris 8),
Dorothea Hartmann (Deutsche Oper Berlin),
Koen Bollen (Opera Ballet Vlaanderen)
In collaboration with
Fondazione Giorgio Cini,
Università Ca' Foscari di Venezia –
Dipartimento di Filosofia e Beni Culturali

4.00, 4.30, 5.00, 5.30 PM
Arsenale – Teatro alle Tese (II)
SOUND INSTALLATION
PAOLO BUONVINO
ÇIATU, 2022 (30') ***
Paolo Buonvino, concept and composition
Irma Blank, art installation
Marco Lucarelli, light
Antonello Pocetti, mise en espace
Fabio Venturi, audio project
La Biennale di Venezia – CIMM, Centro di
Informatica Musicale Multimediale
Thierry Coduys, sound diffusion
production of the Irma Blank art
installation by Bureau Betak for DIOR
Madre, video animation
Maria Alicata, curator visual project
Commission La Biennale di Venezia
Production La Biennale di Venezia
Thanks to House of DIOR
for the production of the costumes
Thanks to P420, Bologna
for Irma Blank's artwork

Out of stage

BIENNALE MUSICA 2022

8.00 PM
Arsenale – Teatro alle Tese (III)
EXPERIMENTAL MUSIC THEATRE
GIORGIO BATTISTELLI
EXPERIMENTUM MUNDI, 1981 (60')
opera di musica immaginistica for one actor,
four women voices,
sixteen craftsmen and solo percussion
Libretto by Giorgio Battistelli
after the *Encyclopédie ou Dictionnaire
raisonné des sciences, des arts et des
métiers* by Denis Diderot
and Jean Le Rond D'Alembert
Peppe Servillo, actor
Nicola Raffone, percussion
Paola Calcagni, Flora Molle, Rosa Pulcini,
Anna Rita Severini, female chorus
Alfredo Sannibale,
Fabio Sannibale, coopers
Roberto Festuccia,
Alberto Casini, carpenters
Marcello Di Palma, baker
Oberdan Carpineti, Pietro Meelli, pavers
Ciro Paudice, Marco Carbone, bricklayers
Gianni Sannibale,
Marco Sannibale, blacksmiths
Aldo Sardilli, Luigi Battistelli, knife sharpeners
Enzo Iezzi, Luigi Diotallevi, cobblers
Francesco Campanella, stone-mason
Angelo Linzalata, light design
Giorgio Battistelli, conductor
La Biennale di Venezia – CIMM, Centro
di Informatica Musicale Multimediale
Thierry Coduys, sound engineer

*** World premiere
* Italian premiere

The program may vary



FREE SHUTTLE BOAT

From Arsenale
to S. Elena – S. Zaccaria –
Zattere – Tronchetto – P.le Roma
after the evening shows

Snack bar service available (Arsenale)

TICKETS

tickets can be purchased online
and one hour before the show at
the ticket office on site

LECTURES, ROUND TABLE GOLDEN AND SILVER LION AWARD CEREMONIES

Free admission

For information, prices and access regulations visit the website

www.labiennale.org
promozione@labiennale.org
T. +39 041 5218 828

Media Partner