

# BIENNALE MUSICA



La Biennale di Venezia

Arte  
Architettura  
Cinema  
Danza  
Musica  
Teatro  
Archivio Storico

## Out of stage

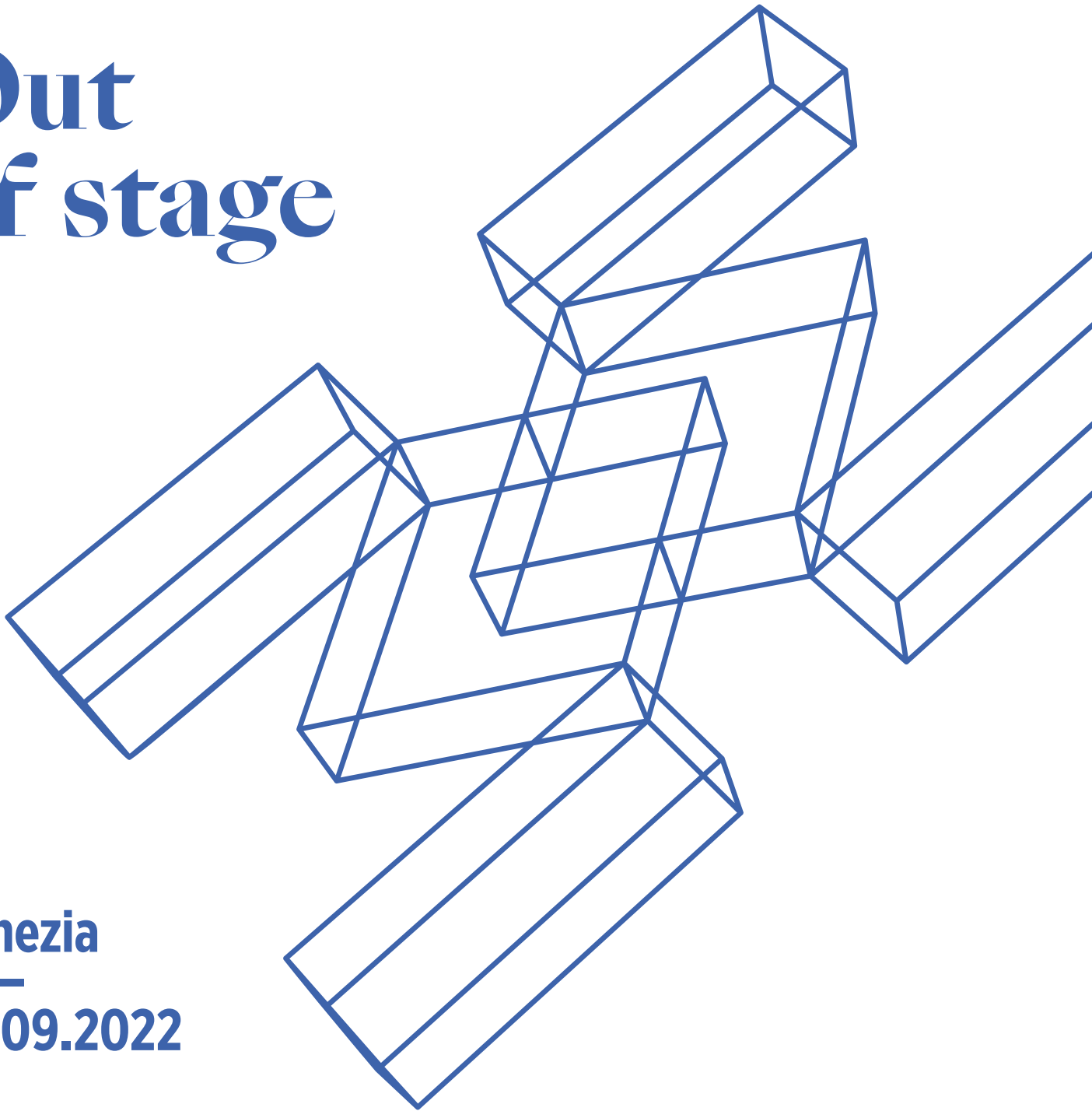

Venezia  
14—  
25.09.2022

#BiennaleMusica2022

-  La Biennale di Venezia
-  labiennale
-  la\_Biennale
-  BiennaleChannel

[labiennale.org](http://labiennale.org)

La Biennale di Venezia  
Ca' Giustinian  
San Marco 1364/A

Info:  
T. +39 041 5218 828  
[promozione@labiennale.org](mailto:promozione@labiennale.org)



REGIONE DEL VENETO

## WEDNESDAY

14.09.22

8.00 PM

Teatro La Fenice

INSTRUMENTAL THEATRE

**GIORGIO BATTISTELLI** (1953)

JULES VERNE, 1987 (60') \*\*\*

Immaginazione in forma di spettacolo

for percussion trio, three voices, trumpet and piano

Libretto by Giorgio Battistelli

Ars Ludi

Antonio Caggiano, Rodolfo Rossi,

Gianluca Ruggeri

Angelo Linzalata, set lighting

Giorgio Battistelli, stage director

La Biennale di Venezia - CIMM,

Centro di Informatica Musicale Multimediale

Thierry Coduys, sound engineer

Production La Biennale di Venezia

In collaboration with

Fondazione Teatro La Fenice

## THURSDAY

15.09.22

15.09, 18.09, 22.09, 23.09, 25.09

H 11.00 AM > 8.00 PM

16.09, 17.09, 19.09 - 21.09, 24.09

H 11.00 AM > 7.00 PM

Arsenale - Entrata

Metaverse (Virtual Platforms)

VIRTUAL SOUND THEATRE

**THIERRY CODUYS** (1962)

LE CAS DE L'HIPPOCAMPE, 2022 (12')

VR triptych

Thierry Coduys, director & musical research

Agnès de Cayeux,

screenplay & graphic world

Patricio Di Bacco, development

of 3D unreal engine

Estelle Senay, Martin Saëz,

server implementation

Vel.Cro, audio engine development

Production, La Biennale di Venezia - CIMM,

Centro Informatico Musicale Multimediale

12.00 PM

Ca' Giustinian - Sala delle Colonne

Award Ceremony

Golden Lion for Lifetime Achievement

**GIORGIO BATTISTELLI**

H 12.30

Helga de la Motte in dialogue

with Giorgio Battistelli (30')

5.00 PM

Arsenale - Sala d'Armi A

SOUND INSTALLATION

BIENNALE COLLEGE MUSICA 2022

**PAUL HAUPTMEIER** (1993)

DIAPHANOUS SOUND, 2022 (30') \*\*\*

augmented reality sound installation

Production La Biennale di Venezia - CIMM,

Centro di Informatica Musicale Multimediale

15.09 H 17.00 > 19.30,

16-17.09 H 11.00 > 20.00,

18.09 H 11.00 > 19.30

8.00 PM

Arsenale - Teatro alle Tese (III)

EXPERIMENTAL MUSIC THEATRE

**ONDŘEJ ADÁMEK** (1979)

**RINO MURAKAMI** (1995)

**ERIC OBERDORFF**

REACHING OUT, 2022 (55') \*

MOVING VOICES

**ONDŘEJ ADÁMEK**

KNOCK EARTH STONE DUST (20')

based on man time stone time for six

singers, two percussionists, two dancers

Lyrics by Sjón (Sigurjón Birgir Sigurðsson)

**RINO MURAKAMI**

SALMON CROSSING (15')

FOR SIX SINGERS, TWO

PERCUSSIONISTS, TWO DANCERS

Text after *Sake No Uta (Salmon Song)*

By Keiko Oguro

**ONDŘEJ ADÁMEK**

SCHLAFEN GUT. WARM. (20')

new version for six singers, two

Performers, two dancers

Ondřej Adámek, Eric Oberdorff,

concept and staging

Jean-Gabriel Valot, light design

Marie Hoffmann, production

Ensemble N.E.S.E.V.E.N.

(Never Ending Searching for Exact

Vocal Expression and Nuances)

Olga Siemieńczuk, Shigeko Hata,

Landy Andriamboavonjy, Nicolas Simeha,

Steve Zheng, Paul-Alexandre Dubois,

voice, objects and movement

Compagnie Humaine

Cécile Robin Prévallée, Pierre Theoleyre,

movement and objects

Jeanne Larroutourou, Miguel Angel García

Martin, instruments, objects and movement

Co-Production, La Biennale di Venezia,

GMEM (Groupe de Musique Expérimental

de Marseille) - Centre national de création

musicale, Scène 55 - Mougins / scène con-

ventionnée d'intérêt, C.I.R.M. Centre National

de création musicale (France)

With support by Goethe institut (Germany),

DAAD (German Academic Exchange Servi-

ce), SACEM (France)

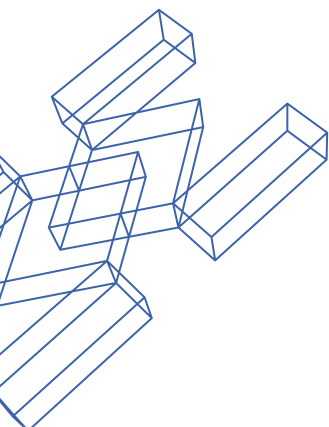

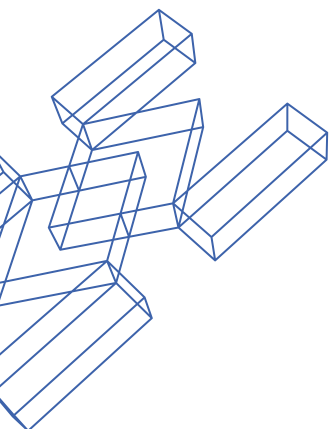

10.30 PM  
Ca' Giustinian – Sala delle Colonne  
RADIO LIVE  
Rai Radio3 – Il teatro di Radio3  
BIENNALE COLLEGE MUSICA 2022  
**GEMMA RAGUÉS** (1993)  
VERITÀ A VENEZIA, 2022 (50') \*\*\*  
Gemma Ragués, vocal  
and experimental performance  
Production La Biennale di Venezia – CIMM,  
Centro di Informatica Musicale Multimediale

FRIDAY  
16.09.2022

11.00 AM  
Ca' Giustinian – Sala delle Colonne  
LECTURE  
**LAURA BERMAN**  
NEW MUSIC THEATRE, YESTERDAY,  
TODAY AND TOMORROW (50')  
An aperitif will follow

7.00 PM  
Teatro Piccolo Arsenale  
EXPERIMENTAL MUSIC THEATRE  
SIMON STEEN-ANDERSEN  
**THE RETURN (A.K.A. RUN TIME  
ERROR @ VENICE FEAT. MONTEVERDI),**  
2022 (60') \*\*\*

music theatre for three singers,  
baroque ensemble, objects  
and video based upon  
*Il ritorno d'Ulisse in patria*  
by Claudio Monteverdi  
Libretto by Giacomo Badoaro,  
with original stage directions,  
edits and additions by  
by Simon Steen-Andersen  
Giulia Bolcato, soprano  
Anicio Zorzi Giustiniani, tenor  
Davide Giangregorio, bass-baritone  
VenEthos Ensemble  
Fabiano Martignago,  
Anna Chiara Mondin, recorders  
Giacomo Catana, Mauro Spinazzè, violins  
Francesco Lovato, viola  
Leonardo Galligioni, doublebass  
Simone Vallerotonda, thiorbo  
Alberto Busetini, cembalo (also regal)  
Massimo Raccanelli, cello, conductor  
Simon Steen-Andersen, concept,  
staging, mic- and joystick-performer  
Peter Tinning, camera performer  
Ellen Rosand, Stefano Nardelli,  
interviews  
La Biennale di Venezia – CIMM,  
Centro di Informatica Musicale Multimediale  
Thierry Coduys, ingegnere del suono  
Commission La Biennale di Venezia,  
funded by Ernst von Siemens Music  
Foundation  
Production, La Biennale di Venezia  
Thanks to VELA S.p.a. and Comune  
di Venezia – Venice Film Commission  
for collaboration during shooting  
in February

9.00 PM  
Mestre – Teatro del Parco  
EXPERIMENTAL PERFORMANCE  
**KLEIN**  
PERFORMANCE, 2022 (30') \*\*\*

**DANIELE CARCASSI, X. LEE**  
PARALLAX, 2022 (30') \*\*\*  
EXPERIMENTAL PERFORMANCE  
Production, La Biennale di Venezia – CIMM,  
Centro di Informatica Musicale Multimediale  
In collaboration with  
Settore Cultura Comune di Venezia

SATURDAY  
17.09.2022

9.00 AM  
Ca' Giustinian – Sala delle Colonne  
RADIO LIVE  
RAI RADIO3 – LEZIONI DI MUSICA  
**GIOVANNI BIETTI**  
**FRANCESCO CAVALLI, IL GIASONE**  
Teatro San Cassian, 1649 (30')  
A coffee break will follow

12.00 PM  
Ca' Giustinian – Sala delle Colonne  
Award Ceremony Silver Lion  
**ARS LUDI**

12.30 PM  
Guido Barbieri in dialogue with Ars Ludi (30')

6.00 PM  
Teatro Piccolo Arsenale  
EXPERIMENTAL MUSIC THEATRE  
**SIMON STEEN-ANDERSEN** (1976)  
THE RETURN (A.K.A. RUN TIME  
ERROR @ VENICE FEAT.  
MONTEVERDI), 2022 (60')

8.00 PM  
Fondazione Giorgio Cini – Lo Squero  
INSTRUMENTAL THEATRE  
BIENNALE COLLEGE MUSICA 2022  
Hosted by Tom Service (BBC Radio 3)

**FRANÇOIS SARHAN** (1972)  
SITUATION 4 – VICE VERSA, 2010 (4')  
for two performers  
Kathryn Vetter, Dafne Paris, performers

**GEORGES APERGHIS** (1945)  
GRAFFITIS, 1981 (20')  
for a percussionist  
Federico Tramontana, percussion

SIX TOURBILLONS, 1989 (12')  
for female voice  
Esther-Elisabeth Rispens, soprano

TRYPTIQUE – FIDÉLITÉ (PART III), 1982 (16')  
for harp  
Dafne Paris, harp

7 CRIMES DE L'AMOUR, 1979 (12')  
for soprano, clarinet and percussion  
Esther-Elisabeth Rispens, soprano  
Kathryn Vetter, clarinet  
Federico Tramontana, percussion

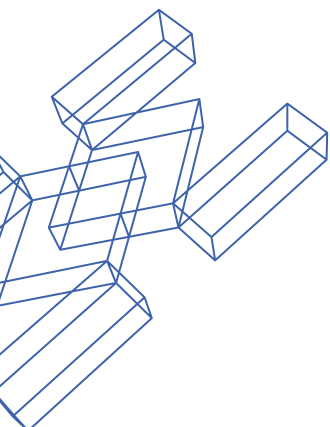

**CAROLA BAUCKHOLT** (1959)  
HIRN & EI  
(FRAGMENTS OF THE SCORE), 2010 (4')  
for four performers  
Dafne Paris, Esther-Elisabeth Rispens,  
Kathryn Vetter, Federico Tramontana  
Production, La Biennale di Venezia

**SUNDAY**  
18.09.22  
9.00 AM  
Ca' Giustinian – Sala delle Colonne  
RADIO LIVE  
RAI RADIO3 – LEZIONI DI MUSICA  
**GIOVANNI BIETTI**  
**ANTONIO VIVALDI, ORLANDO**  
Teatro dell'Angelo, 1727 (30')  
A coffee break will follow

11.00 AM  
Conservatorio "Benedetto Marcello" –  
Sala dei concerti  
LECTURE  
**PAUL HAUPTMEIER**  
PERSPECTIVES ON THE USE  
OF EXTENDED REALITIES  
IN SOUND ART AND COMPOSITION (50')

H 16.00  
Biblioteca Marciana – Salone Sansoviniano  
PERFORMATIVE LECTURE  
AD IMITATIONE DELLE PASSIONI (30')  
"Canto" and "declamato" between Florence  
and Venice in early seventeenth Century  
Texts by Claudio Monteverdi  
and Giulio Caccini  
Paolo Da Col, lecture  
and vocal performance  
INSTRUMENTAL THEATRE  
**MEHDI JALALI** (1980)  
UNFOLDING, 2022 (30') \*\*\*  
praying ritual for solo tanbur  
Improvisation on maqams by  
Khan-Amiri, Sahari, Chupi-Razbaari,  
Savar-Savar and Jelo-Shahi  
RAGHS-E-SAMA  
from KHAT-E-SEVOM, 2016  
Mehdi Jalali, tanbur

8.00 PM  
Arsenale – Tese dei Soppalchi  
INSTRUMENTAL THEATRE  
Hosted by Tom service (BBC Radio 3)  
**GIORGIO BATTISTELLI** (1953)  
ORAZI E CURIAZI, 1996 (13')  
for two percussionists  
Ars Ludi  
Antonio Caggiano, Gianluca Ruggeri  
**MAURICIO KAGEL** (1931-2008)  
DRESSUR, 1977 (30')  
percussion trio for wooden instruments  
Ars Ludi  
Antonio Caggiano, Rodolfo Rossi,  
Gianluca Ruggeri

**MONDAY**  
19.09.2022  
11.00 AM  
Conservatorio "Benedetto Marcello"  
Sala dei concerti  
LECTURE  
**ELLEN ROSAND**  
THE FIRST EXPERIMENTAL  
MUSIC THEATRE:  
VENETIAN OPERA (50')

8.00 PM  
Teatro Goldoni  
EXPERIMENTAL MUSIC THEATRE  
**MICHEL VAN DER AA**  
THE BOOK OF WATER, 2022 (70') \*\*\*  
music theatre for actor, string quartet  
and film based upon *Der Mensch  
erscheint im Holozän* by Max Frisch  
adapted by Michel van der Aa  
Samuel West, narrator, geiser  
Timothy West, geiser (film)  
Mary Bevan, Corinne (soprano, film)  
Ensemble Modern String Quartet  
Jagdish Mistry, Giorgos Panagiotidis, violins  
Megumi Kasakawa, viola  
Eva Böcker, cello  
Michael van der Aa, composition,  
stage director and script  
Madelon Kooijman, dramaturgy  
Bart van den Heuvel, light design  
Djoere de Jong, production  
Paul Jeukendrup, sound design  
Judith de Zwart, costume design  
Joost Rietdijk nsc, director of photography  
Arjen Oosterbaan, Eastbound Films,  
executive producer film  
Djoere de Jong, ProductieCollectief,  
production manager  
Siemen van der Werf,  
technical director  
Martijn van Nunen, stage manager  
Fergus McAlpine, play-out operator  
Douwe Bulten, light operator  
Tomas Valečka, sound operator  
Commission La Biennale di Venezia, Ensem-  
ble Modern, Muziekgebouw Amsterdam,  
Amsterdam Sinfonietta, November Music,  
Philharmonie Cologne  
With financial support of Ammodo, Prins  
Bernhard Cultuurfonds, Cultuurfonds Bank  
Nederlandse Gemeenten,  
Ernst Von Siemens Music Foundation,  
Stiching Reinbert de Leeuw,  
Société Gavignières  
Foundation doubleA is supported by Per-  
forming Arts Fund NL

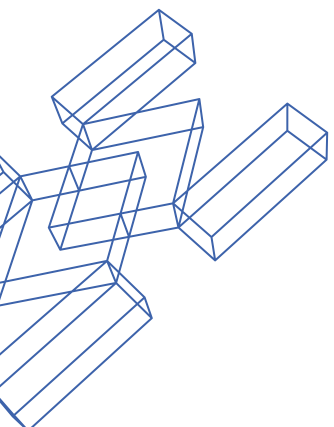

## TUESDAY

20.09.2022

11.00 AM

Conservatorio "Benedetto Marcello"  
Sala dei concerti  
LECTURE

**MICHEL VAN DER AA** (50')

6.00 PM

Ca' Giustinian – Sala delle Colonne  
CHORAL MUSIC THEATRE  
NATIVE AMERICAN INSPIRATIONS \*\*\*  
a music drama in voice

**BRENT MICHAEL DAVIDS** (1959)

MOHICAN SOUP, 1997  
NIGHT CHANT, 1996  
CITY OF WATER, 2022  
Commission Shenandoah Conservatory

**RUSSELL WALLACE** (1965)

ST'AT'IMC  
JOURNEY, 2002

**LOUIS BALLARD** (1931–2007)

QUAPAW/CHEROKEE  
MOHAVE BIRD DANCE SONGS, ARR. 2003

**DAWN Ierihokwats AVERY**

MOHAWK/KANIËNKÉHA (1961)  
TEIONKHIYÀ:TATON, 2022

**JENNIFER STEVENS** (1972)

ONEIDA  
BEGINNING OF TIME, 2022

Vocal Ensemble Students  
Shenandoah Conservatory &  
Shenandoah University  
Austin Thorpe, conductor  
Ella Marchment, director  
Co-production La Biennale di Venezia,  
Sala 1 – Centro Internazionale d'Arte  
Contemporanea, Shenandoah Conservatory

9.00 PM

Mestre – Teatro del Parco  
EXPERIMENTAL PERFORMANCE  
**YVETTE JANINE JACKSON** (1973)

LEFT BEHIND, 2022 (60') \*\*\*

a radio opera  
Radio Opera Workshop Ensemble  
Malesha Jessie Taylor, voice  
Joy Guidry, bassoon  
Amy Cimini, viola  
Judith Hamann, cello  
Tommy Babin, double bass  
Yvette Janine Jackson, electronics  
In collaboration with  
Settore Cultura Comune di Venezia

## WEDNESDAY

21.09.2022

11.00 AM

Conservatorio "Benedetto Marcello"  
Sala dei concerti  
LECTURE

**YVETTE JANINE JACKSON** (50')

9.00 PM

Basilica di San Marco  
SACRED REPRESENTATION

**HELENA TULVE** (1972)

VISIONS, 2022 (50') \*\*\*  
for vocal ensemble, "cori spezzati"  
and multiple instrumental ensembles  
Text by Helena Tulve

After fragments of sacred representation  
found by Giulio Cattin in Santa  
Maria della Fava and the Gospel  
of Mary Magdalene

Vox Clamantis

Jaan-Eik Tulve, conductor

Cappella Marciana

Marco Gemmani, conductor

Marco Ambrosini, Angela Ambrosini,  
nyckelharpa

Anna-Liisa Eller, kannel, percussion

Ensemble Barocco del Conservatorio  
"Benedetto Marcello" di Venezia

Francesco Erle, conductor

Marius Peterson, stage director

Commission La Biennale di Venezia,  
funded by Ernst von Siemens Music  
Foundation

Production La Biennale di Venezia

In collaboration with Basilica  
e Procuratoria di San Marco

THURSDAY  
22.09.2022  
10.00 AM > 12.00 PM  
Fondazione Ugo e Olga Levi –  
Sala Biblioteca  
ROUND TABLE  
GIULIO CATTIN'S CRITICAL  
RECONSTRUCTION OF THE FOURTEEN-  
TH-CENTURY LITURGICAL DRAMAS  
IN SANTA MARIA DELLA FAVA  
AND HELENA TULVE'S NEW TREATMENT  
OF THE COMPOSITION  
Helena Tulve  
(Estonian Academy of Music and Theatre),  
Roberto Calabretto (Fondazione Ugo  
e Olga Levi, Università di Udine),  
Antonio Lovato (Università di Padova),  
Francesco Erle (Conservatorio  
"Benedetto Marcello" di Venezia)  
in collaboration with  
Fondazione Ugo e Olga Levi

4.00, 6.00 PM  
Arsenale – Sala d'Armi E  
PERFORMATIVE SOUND INSTALLATION  
**ALEXANDER SCHUBERT** (1979)  
SLEEP LABORATORY, 2022 (50') \*  
performative installation for  
musicians/performers and VR/360 Video  
United Instruments of Lucilin  
Sophie Deshayes, flute  
Winnie Cheng, violin  
Danielle Hennicot, viola  
Ingrid Schoenlaub, cello  
Pascal Meyer, piano  
Guy Frisch, percussion  
WE ARE VISUAL  
Marc Einsiedel, Felix Jung, set  
Multimedia Kontor Hamburg (MMKH)  
Leonhard Onken Menke, Sebastian Olariu,  
VR/360 Video  
Tobias Johannes Pfeil, co-development  
and artistic collaboration  
Felina Levits, costumes  
Jonathan Harth, scientific adviser  
Alexander Schubert, concept, stage director  
Music Published  
Licensed by: © Deuss Music, The Hague  
www.deussmusic.com  
Co-production La Biennale di Venezia,  
ACHT BRÜCKEN-Musik für  
Köln, Philharmonie Luxemburg (rainy days  
festival), United Instruments of Lucilin

8.00 PM  
Arsenale – Teatro alle Tese (II)  
EXPERIMENTAL MUSIC THEATRE  
**PAOLO BUONVINO** (1968)  
CIATU, 2022 (50') \*\*\*  
for vocalists, disklaviers, ensemble,  
recorded voices and live electronics  
Text by Paolo Buonvino  
based on literary and documentary frag-  
ments about the concept of breath in Sicily  
Paolo Buonvino, piano and live electronics  
Rossella Ruini, Badara Seck,  
Faisal Taher, vocalists  
Pasquale Laino, wind instruments  
and live electronics  
Seby Burgio, keyboard and live electronics  
PMCE - Parco della Musica  
Contemporanea Ensemble  
Manuel Zurria, flutes  
Paolo Ravaglia, ethnic flutes and clarinets  
Flavio Tanzi, percussion  
Francesco Peverini, violin I  
Filippo Fattorini, violin II  
Luca Sanzò, viola  
Anna Armatys, cello  
Massimo Ceccarelli, doublebass  
Tommaso Cancellieri, sound design  
Fabio Venturi, audio project  
Tonino Battista, conductor  
2 Yamaha Disklavier D U1 EN verticals  
1 Yamaha C7X EN Disklavier  
Thierry Coduys, Paolo Buonvino, sound  
design and live electronics  
Silvia Barbera, musical assistant  
Irma Blank, art installation  
Maria Grazia Chiuri per / for DIOR, costumes  
Antonello Pocetti, direction  
Marco Lucarelli, light project  
Maria Alicata, curator art project  
production of the Irma Blank art  
installation by Bureau Betak for DIOR  
Madre, video animation  
Commission La Biennale di Venezia  
Production La Biennale di Venezia  
Thanks to House of DIOR for the production  
of the costumes  
Thanks to P420, Bologna for Irma Blank's  
artwork

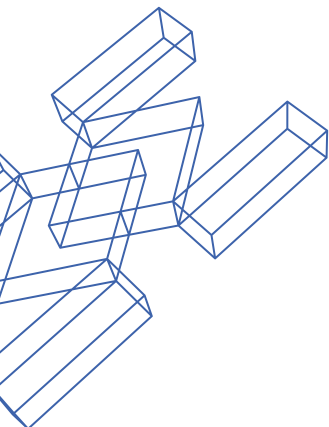

# Out of stage

## BIENNALE MUSICA 2022

### FRIDAY

23.09.2022

11.00 AM

Conservatorio "Benedetto Marcello"  
Sala dei concerti  
LECTURE

**ONDŘEJ ADÁMEK** (50')

4.00 PM > 5.30 PM

Arsenale - Teatro alle Tese (II)  
SOUND INSTALLATION

**PAOLO BUONVINO**

ÇIATU, 2022 (30') \*\*\*

Paolo Buonvino, concept and composition  
Irma Blank, art installation  
Marco Lucarelli, light

Antonello Pocetti, mise en espace

Fabio Venturi, audio project

La Biennale di Venezia - CIMM, Centro di  
Informatica Musicale Multimediale

Thierry Coduys, sound diffusion

production of the Irma Blank art  
installation by Bureau Betak for DIOR

Madre, video animation

Maria Alicata, curator art project

Commission La Biennale di Venezia

Production La Biennale di Venezia

Thanks to House of DIOR

for the production of the costumes

Thanks to P420, Bologna

for Irma Blank's artwork

8.00 PM

Arsenale - Tese dei Soppalchi  
EXPERIMENTAL PERFORMANCE  
BIENNALE COLLEGE MUSICA 2022

**TANIA CORTÉS** (1993)

R I Z O M A, 2022 (30') \*\*\*

for electronics and video

Tania Cortés, performer

**JACOPO CENNI**

HUNT, 2022 (30') \*\*\*

sound theatre for electronics

and incandescent light bulbs

Jacopo Cenni, performer

Production La Biennale di Venezia - CIMM,  
Centro di Informatica Musicale Multimediale

### SATURDAY

24.09.2022

9.00 AM

Ca' Giustinian - Sala delle Colonne  
RADIO LIVE

RAI RADIO3 - LEZIONI DI MUSICA

**GIOVANNI BIETTI**

**BRUNO MADERNA, HYPERION**

Teatro La Fenice, 1964 (30')

A coffee break will follow

11.00 AM

Conservatorio "Benedetto Marcello"  
Sala dei concerti

LECTURE

**PAOLO BUONVINO** (50')

4.00 PM > 5.30 PM

Arsenale - Teatro alle Tese (II)  
SOUND INSTALLATION

**PAOLO BUONVINO**

ÇIATU, 2022 (30') \*\*\*

Paolo Buonvino, concept and composition

Irma Blank, art installation

Marco Lucarelli, light

Antonello Pocetti, mise en espace

Fabio Venturi, audio project

La Biennale di Venezia - CIMM, Centro di

Informatica Musicale Multimediale

Thierry Coduys, sound diffusion

production of the Irma Blank art

installation by Bureau Betak for DIOR

Madre, video animation

Maria Alicata, curator art project

Commission La Biennale di Venezia

Production La Biennale di Venezia

Thanks to House of DIOR

for the production of the costumes

Thanks to P420, Bologna

for Irma Blank's artwork

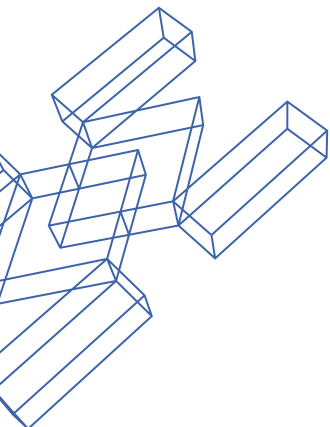

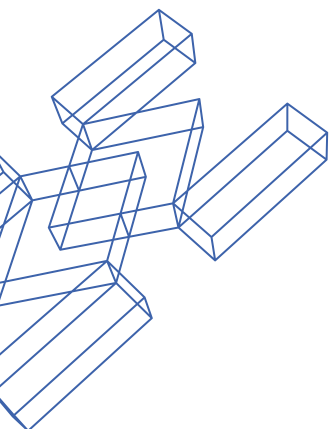

6.00 PM  
Teatro Piccolo Arsenale  
EXPERIMENTAL MUSIC THEATRE  
BIENNALE COLLEGE MUSICA  
COMPOSER  
**TIMOTHY CAPE** (1991)  
STILL DROWSY, 2022 (30') \*\*\*  
performative music theatre for voice,  
percussion trio and sound diffusion  
Text collated by Timothy Cape  
Esther-Elisabeth Rispens, soprano  
Ars Ludi  
Antonio Caggiano, Rodolfo Rossi,  
Gianluca Ruggeri  
**DANIIL POSAZHENNIKOV**  
RELICT, 2022 (35') \*\*\*  
linguistic mantram for voice,  
percussion trio, video and electronics  
Libretto by Egor Zaytsev  
Esther-Elisabeth Rispens, soprano  
Ars Ludi  
Antonio Caggiano, Rodolfo Rossi,  
Gianluca Ruggeri  
Daniil Posazhennikov, stage director  
Egor Zaytsev, dramaturgy  
Production La Biennale di Venezia – CIMM,  
Centro di Informatica Musicale Multimediale

9.00 PM  
Scuola Grande di San Rocco  
MADRIGALE RAPPRESENTATIVO  
**ANNELIES VAN PARYS** (1975)  
NOTWEHR, 2022 (50') \*\*\*  
for two singers, vocal and instrumental  
ensemble based upon *Barca di Venetia  
per Padova - Dilettevoli Madrigali à cinque  
Voci* by Adriano Banchieri, 1605-1623  
Libretto by Gaea Schoeters  
after Adriano Banchieri  
Johanna Zimmer, soprano  
Els Mondelaers, mezzo-soprano  
VENETIAETERNA vocal ensemble  
Silvia Porcellini, soprano  
Elisabetta Cuman, mezzo-soprano  
Miranda Ying Quan, contralto  
Giacomo Schiavo, tenor  
Francisco Augusto Bois, bass  
Francesco Erle, conductor  
HERMESensemble  
Karin de Fleyt, flute  
Stijn Saveniers, cello  
Bram Fournier, trombone  
Gaetan La Mela, percussion  
Sjaron Minailo, mise en scène  
Commission La Biennale di Venezia  
Co-production La Biennale di Venezia,  
Studio Minailo, HERMESensemble,  
Muziektheater Transparan  
With support of the Flemish Government

SUNDAY  
25.09.2022  
9.00 AM  
Ca' Giustinian – Sala delle Colonne  
RADIO LIVE  
RAI RADIO3 – LEZIONI DI MUSICA  
**GIOVANNI BIETTI**  
**LUIGI NONO, INTOLLERANZA**  
Teatro La Fenice, 1961 (30')  
A coffee break will follow  
  
11.00 AM  
Ca' Giustinian – Sala delle Colonne  
Award Ceremony of the Jury Prize of  
Students from Italian Conservatories (30')  
Guido Barbieri, Coordinator of the Jury  
  
2.00 > 4.00 PM  
Fondazione Giorgio Cini – Sala Barbantini  
ROUND TABLE  
MUSIC THEATRE TODAY.  
VOICES, ACTIONS, TECHNOLOGIES  
Coordinators:  
Gianmario Borio (Fondazione Giorgio Cini,  
Università di Pavia),  
Vincenzina Caterina Ottomano  
(Università Ca' Foscari di Venezia)  
Participants:  
Robert Adlington  
(University of Huddersfield),  
Susanne Kogler (Universität Graz),  
Giordano Ferrari (Université Paris 8),  
Dorothea Hartmann (Deutsche Oper Berlin),  
Koen Bollen (Opera Ballet Vlaanderen)  
In collaboration with  
Fondazione Giorgio Cini,  
Università Ca' Foscari di Venezia –  
Dipartimento di Filosofia e Beni Culturali  
  
4.00 PM > 5.30 PM  
Arsenale – Teatro alle Tese (II)  
SOUND INSTALLATION  
**PAOLO BUONVINO**  
ÇIATU, 2022 (30') \*\*\*  
Paolo Buonvino, concept and composition  
Irma Blank, art installation  
Marco Lucarelli, light  
Antonello Pocetti, mise en espace  
Fabio Venturi, audio project  
La Biennale di Venezia – CIMM, Centro di  
Informatica Musicale Multimediale  
Thierry Coduys, sound diffusion  
production of the Irma Blank art  
installation by Bureau Betak for DIOR  
Madre, video animation  
Maria Alicata, curator art project  
Commission La Biennale di Venezia  
Production La Biennale di Venezia  
Thanks to House of DIOR  
for the production of the costumes  
Thanks to P420, Bologna  
for Irma Blank's artwork



# Out of stage

# BIENNALE MUSICA 2022

8.00 PM  
Arsenale – Teatro alle Tese (III)  
EXPERIMENTAL MUSIC THEATRE  
**GIORGIO BATTISTELLI**  
EXPERIMENTUM MUNDI, 1981 (60')  
opera di musica immaginistica for one actor,  
four women voices,  
sixteen craftsmen and solo percussion  
Libretto by Giorgio Battistelli  
after the *Encyclopédie ou Dictionnaire  
raisonné des sciences, des arts et des  
métiers* by Denis Diderot  
and Jean Le Rond D'Alembert  
Peppe Servillo, actor  
Nicola Raffone, percussion  
Paola Calcagni, Flora Molle, Rosa Pulcini,  
Anna Rita Severini, female chorus  
Alfredo Sannibale,  
Fabio Sannibale, coopers  
Roberto Festuccia,  
Alberto Casini, carpenters  
Marcello Di Palma, baker  
Oberdan Carpineti, Pietro Meelli, pavers  
Ciro Paudice, Marco Carbone, bricklayers  
Gianni Sannibale,  
Marco Sannibale, blacksmiths  
Aldo Sardilli, Luigi Battistelli, knife sharpeners  
Enzo Iezzi, Luigi Diotallevi, cobblers  
Francesco Campanella, stone-mason  
Angelo Linzalata, light design  
Giorgio Battistelli, conductor  
La Biennale di Venezia – CIMM, Centro  
di Informatica Musicale Multimediale  
Thierry Coduys, sound engineer

\*\*\* World premiere  
\* Italian premiere

The program may vary



#### FREE SHUTTLE BOAT

From Arsenale  
to S. Elena – S. Zaccaria –  
Zattere – Tronchetto – P.le Roma  
after the evening shows

Snack bar service available (Arsenale)

#### TICKETS

tickets can be purchased online  
and one hour before the show at  
the ticket office on site

#### LECTURES, ROUND TABLE GOLDEN AND SILVER LION AWARD CEREMONIES

Free admission

#### For information, prices and access regulations visit the website

[www.labiennale.org](http://www.labiennale.org)  
[promozione@labiennale.org](mailto:promozione@labiennale.org)  
T. +39 041 5218 828

Media Partner