

# BIENNALE MUSICA



La Biennale di Venezia

Arte  
Architettura  
Cinema  
Danza  
Musica  
Teatro  
Archivio Storico

## Out of stage

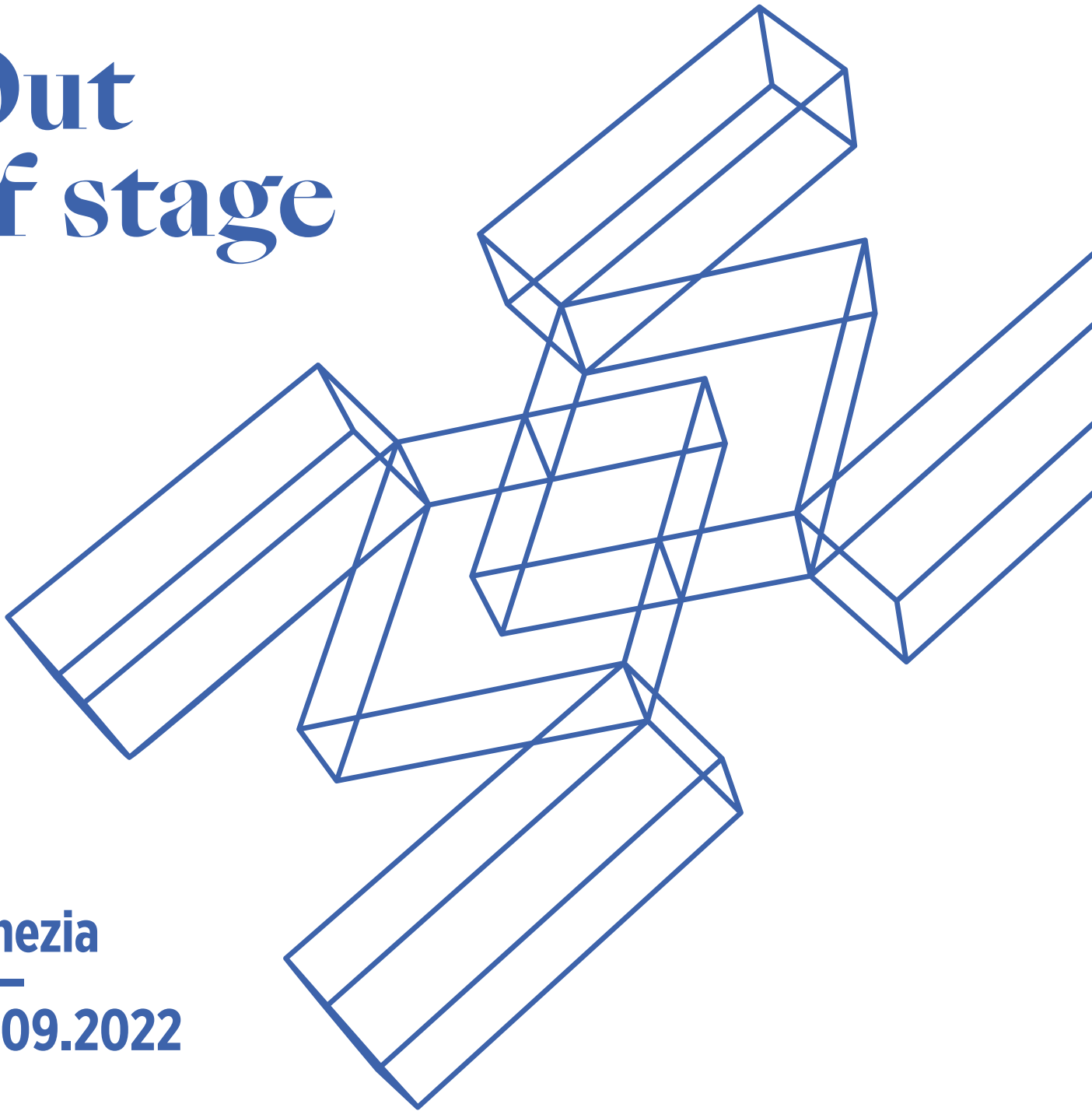

Venezia  
14—  
25.09.2022

#BiennaleMusica2022

-  La Biennale di Venezia
-  labiennale
-  la\_Biennale
-  BiennaleChannel

[labiennale.org](http://labiennale.org)

La Biennale di Venezia  
Ca' Giustinian  
San Marco 1364/A

Info:  
T. +39 041 5218 828  
[promozione@labiennale.org](mailto:promozione@labiennale.org)



REGIONE DEL VENETO

## WEDNESDAY

14.09.2022

8.00 PM

Teatro La Fenice

INSTRUMENTAL THEATRE

**GIORGIO BATTISTELLI**

JULES VERNE, 1984-85 (60') \*\*\*

Immaginazione in forma di spettacolo  
for percussion trio, three voices,  
trumpet and piano

Libretto by Giorgio Battistelli

Ars Ludi

Gianluca Ruggeri, Antonio Caggiano,  
Rodolfo Rossi

Angelo Linzalata, set/light design

Giorgio Battistelli, stage director

CIMM - Centro di Informatica Musicale

Multimediale della Biennale di Venezia

Thierry Coduys, sound engineer

Production La Biennale di Venezia

In collaboration with

Fondazione Teatro La Fenice

## THURSDAY

15.09.2022

12.00 PM

Ca' Giustinian - Sala delle Colonne

Award Ceremony

Golden Lion for Lifetime Achievement

**GIORGIO BATTISTELLI**

12.30

Helga de la Motte in dialogue  
with Giorgio Battistelli (30')

5.00 PM

Arsenale - Sala d'Armi A

SOUND INSTALLATION

BIENNALE COLLEGE MUSICA

COMPOSER

**PAUL HAUPTMEIER**

DIAPHANOUS SOUND, 2022 (30') \*\*\*

Augmented reality sound installation

Production La Biennale di Venezia,

CIMM - Centro di Informatica Musicale

Multimediale della Biennale di Venezia

15>25.09.2022

8.00 PM

Arsenale - Teatro alle Tese (III)

EXPERIMENTAL MUSIC THEATRE

**ONDŘEJ ADÁMEK**

**RINO MURAKAMI**

REACHING OUT, 2022 (55') \*

moving voices

**ONDŘEJ ADÁMEK**

KNOCK EARTH STONE DUST (20')

based on *Man Time Stone Time*

for six singers, two percussionists,

two dancers

Lyrics by Sjón (Sigurjón Birgir Sigurðsson)

**RINO MURAKAMI**

SALMON CROSSING (15')

for six singers, two percussionists,

two dancers

Text after *Sake no Uta*

(*Salmon Song*) by Keiko Oguro

**ONDŘEJ ADÁMEK**

SCHLAFEN GUT. WARM (20')

new version for six singers,

two performers, two dancers

Ondřej Adámek, Eric Oberdorff,

concept and staging

Jean-Gabriel Valot, light design

Marie Hoffmann, production

Ensemble N.E.S.E.V.E.N.

(Never Ending Searching for Exact Vocal  
Expression and Nuances)

Olga Siemieńczuk, Shigeko Hata,

Landy Andriamboavonjy, Nicolas Simeha,

Steve Zheng, Paul-Alexandre Dubois,

voice, objects and movement

Compagnie Humaine

Cécile Robin Prévallée, Luc Bérad,

movement, objects

Jeanne Larroutourou, Miguel Angel Garcia

Martin, instruments, objects and movement

Coproduction La Biennale di Venezia,

GMEM (Groupe de Musique Expérimental

de Marseille)-Centre national de création

musicale

10.30 PM

Ca' Giustinian - Sala delle Colonne

RADIO LIVE

Rai Radio3 - Il teatro di Radio3

BIENNALE COLLEGE MUSICA

COMPOSER

**GEMMA RAGUÉS**

VERITÀ A VENEZIA, 2022 (50') \*\*\*

performative radio composition

Gemma Ragués, vocal

and experimental performance

Production La Biennale di Venezia,

CIMM - Centro di Informatica Musicale

Multimediale della Biennale di Venezia

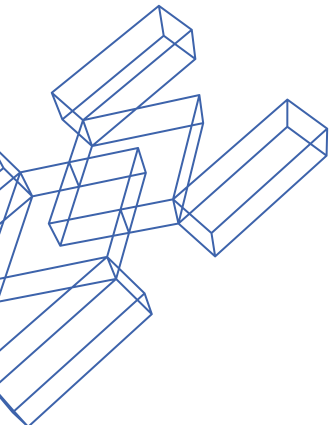

FRIDAY  
16.09.2022  
11.00 AM  
Ca' Giustinian – Sala delle Colonne  
LECTURE  
NEW MUSIC THEATRE YESTERDAY,  
TODAY AND TOMORROW (50')  
Laura Berman, General Manager  
and Artistic Director Staatsoper Hannover

7.00 PM  
Teatro Piccolo Arsenale  
EXPERIMENTAL MUSIC THEATRE  
**SIMON STEEN-ANDERSEN**  
THE RETURN  
(a.k.a. Run Time Error @ Venice  
feat. Monteverdi), 2022 (60') \*\*\*  
Music theatre for three singers,  
baroque ensemble, objects  
and video based upon *Il ritorno  
di Ulisse in patria* by Claudio Monteverdi  
Text by Giacomo Badoaro  
Giulia Bolcato, soprano  
Anicio Zorzi Giustiniani, tenor  
Davide Giangregorio, bass-baritone  
VenEthos Ensemble  
Fabiano Martignago,  
Anna Chiara Mondin, recorder  
Giacomo Catana, Mauro Spinazzè, violins  
Francesco Lovato, viola  
Leonardo Galligioni, doublebass  
Simone Vallerotonda, thiorbo  
Alberto Busettini, cembalo (also regal)  
Massimo Raccanelli, cello and conductor  
Simon Steen-Andersen, concept,  
staging, mic- and joystick performer  
Peter Tinning, camera performer  
Ellen Rosand and Stefano Nardelli,  
video interviews  
Commission La Biennale di Venezia  
Production La Biennale di Venezia  
Thanks to VELA S.p.a e Comune  
di Venezia, Venice Film Commission  
for collaboration during shooting  
in February

9.00 PM  
Teatro del Parco – Mestre  
EXPERIMENTAL PERFORMANCE  
**KLEIN**  
Performance for voice  
and electronics (30') \*\*\*  
**DANIELE CARCASSI, X. LEE**  
PARALLAX (30') \*\*\*  
Experimental performance  
CIMM - Centro di Informatica Musicale  
Multimediale della Biennale di Venezia  
Production La Biennale di Venezia  
In collaboration with  
Settore Cultura Comune di Venezia

SATURDAY  
17.09.2022  
9.00 AM  
Ca' Giustinian – Sala delle Colonne  
RADIO LIVE  
Music Lessons RAI RADIO 3  
Giovanni Bietti, presentation  
**FRANCESCO CAVALLI**  
IL GIASONE  
Teatro San Cassian, 1649 (30')

12.00 PM  
Ca' Giustinian – Sala delle Colonne  
Award Ceremony  
Silver Lion  
**ARS LUDI**  
12.30 PM  
Guido Barbieri in dialogue with Ars Ludi (30')

6.00 PM  
Teatro Piccolo Arsenale  
EXPERIMENTAL MUSIC THEATRE  
**SIMON STEEN-ANDERSEN**  
THE RETURN  
(a.k.a. Run Time Error @ Venice  
feat. Monteverdi), 2022 (60')

8.00 PM  
Fondazione Giorgio Cini – Lo Squero  
INSTRUMENTAL THEATRE  
BIENNALE COLLEGE MUSICA  
PERFORMER  
Hosted by Tom Service (BBC Radio3)  
**FRANÇOIS SARHAN**  
SITUATION 4 – VICE VERSA  
for two performers, 2010 (4')  
Kathryn Vetter, Dafne Paris, performers

**GEORGES APERGHIS**  
GRAFFITIS, 1981 (20')  
for a percussionist  
Federico Tramontana, percussion  
SIX TOURBILLONS, 1989 (12')  
for female voice  
Esther-Elisabeth Rispens, soprano  
TRYPTIQUE – FIDÉLITÉ (PART III), 1982 (16')  
for harp  
Dafne Paris, harp

SEPT CRIMES DE L'AMOUR –  
FOR A MOVIE BY MICHEL FANO, 1979 (12')  
for soprano, clarinet and percussion  
Esther-Elisabeth Rispens, soprano  
Kathryn Vetter, clarinet  
Federico Tramontana, percussion

**CAROLA BAUCKHOLT**  
HIRN & EI  
(fragments of the score), 2010 (4')  
for four performers  
Dafne Paris, Esther-Elisabeth Rispens,  
Kathryn Vetter, Federico Tramontana  
Production La Biennale di Venezia

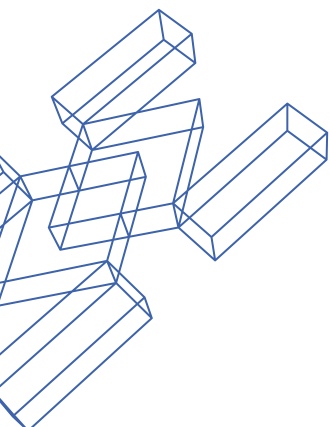

# Out of stage

## BIENNALE MUSICA 2022

### SUNDAY

18.09.2022

9.00 AM

Ca' Giustinian – Sala delle Colonne

RADIO LIVE

Music Lessons RAI RADIO 3

Giovanni Bietti, presentation

**ANTONIO VIVALDI**

ORLANDO

Teatro dell'Angelo, 1727 (30')

11.00 AM

Conservatorio "Benedetto Marcello"

Sala dei concerti

LECTURE (50')

Simon Steen-Andersen

4.00 PM

Biblioteca Marciana – Salone Sansoviniano

PERFORMATIVE LECTURE

"Ad imitacione delle passioni" (30')

"Canto" and "declamato" between Florence and Venice in early XVII Century

Texts by Claudio Monteverdi

and Giulio Caccini

Paolo Da Col, lecture

and vocal performance

INSTRUMENTAL THEATRE

**MEHDI JALALI**

UNFOLDING \*\*\*

Praying ritual for solo tanbur

Improvisation on maqâm by

Khan-Amiri, Sahari, Chupi-Razbaari,

Savar-Savar and Jelo-Shahi

RAGHS-E-SAMA

from KHAT-E-SEVOM, 2016

Mehdi Jalali, tanbur

8.00 PM

Arsenale – Tese dei Soppalchi

INSTRUMENTAL THEATRE

Hosted by Tom service (BBC Radio3)

**MAURICIO KAGEL**

DRESSUR, 1977 (30')

percussion trio for wooden instruments

Ars Ludi

Gianluca Ruggeri, Antonio Caggiano,

Rodolfo Rossi

**GIORGIO BATTISTELLI**

ORAZI E CURIAZI, 1996 (13')

for two percussionists

Ars Ludi

Gianluca Ruggeri, Antonio Caggiano

### MONDAY

19.09.2022

11.00 AM

Conservatorio "Benedetto Marcello"

Sala dei concerti

LECTURE

THE FIRST EXPERIMENTAL

MUSIC THEATER: VENETIAN OPERA (50')

Ellen Rosand, Yale University

8.00 PM

Teatro Goldoni

EXPERIMENTAL MUSIC THEATRE

**MICHEL VAN DER AA**

THE BOOK OF WATER, 2022 (70') \*\*\*

music theatre for actor, string quartet

and film based upon *Der Mensch*

*erscheint im Holozän* by Max Frisch

adapted by Michel van der Aa

Geiser young (live), Samuel West

Geiser elderly (film), Timothy West

Corinne (soprano, film), Mary Bevan

String Quartet Ensemble Modern

Jagdish Mistry, Giorgos Panagiotidis, violins

Megumi Kasakawa, viola

Eva Böcker, cello

Michael van der Aa, composition,

stage director and script

Madelon Kooijman, dramaturgy

Bart van den Heuvel, light design

Djoere de Jong, production

Martijn van Nunen, Siemen van der Werf,

technical production

Norbert Ommer, sound director

(Ensemble Modern)

Commission La Biennale di Venezia, En-

semble Modern, Amsterdam Sinfonietta,

Muziekgebouw Amsterdam

Coproduction La Biennale di Venezia,

doubleAFoundation

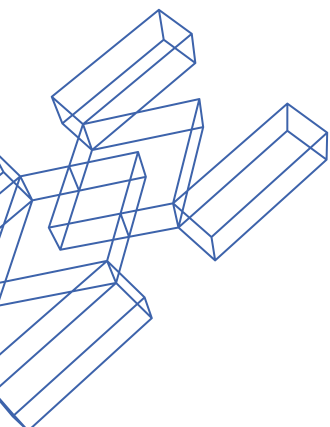

# Out of stage

## BIENNALE MUSICA 2022

### TUESDAY

20.09.2022

11.00 AM

Conservatorio "Benedetto Marcello"  
Sala dei concerti  
LECTURE (50')  
Michel van der Aa

6.00 PM

Ca' Giustinian – Sala delle Colonne  
CHORAL MUSIC THEATRE  
NATIVE AMERICAN INSPIRATIONS \*\*\*  
A music drama in voice

#### **BRENT MICHAEL DAVIDS**

MOHICAN SOUP, 1997  
NIGHT CHANT, 1996  
CITY OF WATER, 2022  
Commission Shenandoah Conservatory

#### **RUSSELL WALLACE**

JOURNEY, 2002, revised 2021

#### **LOUIS BALLARD**

MOHAVE BIRD DANCE SONGS, arr. 2003

#### **DAWN Ieriho:kwats AVERY**

TEIONKHIYA:TATON, 2022

#### **JENNIFER STEVENS**

BEGINNING OF TIME, 2022

Vocal Ensemble Students of Shenandoah  
Conservatory & Shenandoah University  
Matt Oltman, conductor  
Ella Marchment, director  
Coproduction La Biennale di Venezia,  
Sala 1 – Centro Internazionale d'Arte  
Contemporanea, Shenandoah Conservatory

9.00 PM

Teatro del Parco – Mestre  
EXPERIMENTAL PERFORMANCE

#### **YVETTE JANINE JACKSON**

LEFT BEHIND (60') \*\*\*

A radio opera  
Radio Opera Workshop Ensemble  
Malesha Jessie Taylor, voice  
Joy Guidry, bassoon  
Amy Cimini, viola  
Judith Hamann, cello  
Tommy Babin, double bass  
Yvette Janine Jackson, electronics  
In collaboration with  
Settore Cultura Comune di Venezia

### WEDNESDAY

21.09.2022

11.00 AM

Conservatorio "Benedetto Marcello"  
Sala dei concerti  
LECTURE (50')  
Yvette Janine Jackson

9.00 PM

Basilica di San Marco  
SACRED REPRESENTATION

#### **HELENA TULVE**

VISIONS, 2022 (50') \*\*\*

for vocal ensemble, "cori spezzati"  
and multiple instrumental ensembles  
Text by Helena Tulve after fragments  
of sacred representation found  
by Giulio Cattin in Santa Maria della Fava  
in 1994, and the Gospel of Mary Magdalene  
Vox Clamantis  
Jaan-Eik Tulve, conductor  
Cappella Marciana  
Marco Gemmani, conductor  
Marco Ambrosini, Angela Ambrosini,  
nyckelharpa  
Anna-Liisa Eller, kannel, percussion  
Ensemble barocco del Conservatorio  
"Benedetto Marcello" di Venezia  
Francesco Erle, conductor  
Marius Peterson, stage director  
Commission La Biennale di Venezia  
Production La Biennale di Venezia  
In collaboration with Basilica  
e Procuratoria di San Marco

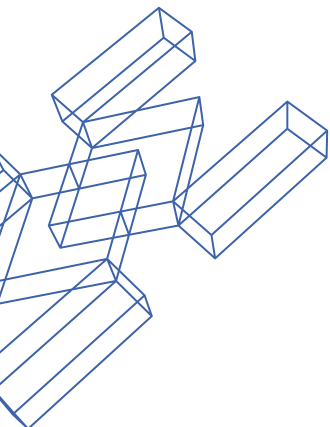



THURSDAY  
22.09.2022  
10.00 AM > 12.00 PM  
Palazzo Giustinian Lolin – Sala Biblioteca

**ROUND TABLE**  
GIULIO CATTIN'S CRITICAL RECONSTRUCTION OF THE 14TH-CENTURY LITURGICAL DRAMAS IN SANTA MARIA DELLA FAVA AND HELENA TULVE'S NEW COMPOSITIONAL TREATMENT  
Helena Tulve  
(Estonian Academy of Music and Theatre),  
Roberto Calabretto (Fondazione Ugo e Olga Levi, Università di Udine),  
Antonio Lovato (Università di Padova),  
Francesco Erle (Conservatorio "Benedetto Marcello" di Venezia)  
in collaboration with  
Fondazione Ugo e Olga Levi

4.00, 6.00 AM  
Arsenale – Sala d'Armi E  
PERFORMATIVE SOUND INSTALLATION  
**ALEXANDER SCHUBERT**  
SLEEP LABORATORY, 2022 (50') \*  
Performative Installation for  
musicians/performers and VR/360 Video  
United Instruments of Lucilin  
Sophie Deshayes, flute  
Winnie Cheng, violin  
Danielle Hennicot, viola  
Ingrid Schoenlaub, cello  
Pascal Meyer, piano  
Guy Frisch, percussions  
WE ARE VISUAL  
Marc Einsiedel, Felix Jung, set  
Multimedia Kontor Hamburg (MMKH)  
Leonhard Onken Menke, Sebastian Olariu,  
VR, 360 Video  
Tobias Johannes Pfeil, co-development  
and artistic collaboration  
Felina Levits, costumes  
Jonathan Harth, scientific adviser  
Alexander Schubert, concept, stage director  
Coproductio La Biennale di Venezia,  
ACHT BRÜCKEN-Musik für Köln,  
Philharmonie Luxemburg  
(rainy days festival),  
United Instruments of Lucilin  
22.09 > 25.09.2022  
12.00, 2.00, 4.00, 6.00 PM

8.00 PM  
Arsenale – Teatro alle Tese (II)  
EXPERIMENTAL MUSIC THEATRE  
**PAOLO BUONVINO**  
ÇIATU, 2022 (50') \*\*\*  
for vocalists, disklaviers, ensemble,  
recorded voices and live electronics  
Text by Paolo Buonvino  
based on literary and documentary frag-  
ments about the concept of breath in Sicily  
PMCE - Parco della Musica  
Contemporanea Ensemble  
Manuel Zurria, flute

Paolo Ravaglia, clarinet  
Francesco Peverini, Filippo Fattorini, violins  
Luca Sanzò, viola  
Anna Armatys, cello  
Massimo Ceccarelli, doublebass  
Flavio Tanzi, percussion  
Paolo Buonvino, Yamaha C7X EN Disklavier  
Yamaha Disklavier D U1 EN  
Tonino Battista, conductor  
Thierry Coduys, Paolo Buonvino,  
Tommaso Cancellieri, sound design  
and live electronics  
Marco Lucarelli, light project  
Antonello Pocetti, stage director  
Commission La Biennale di Venezia  
Production La Biennale di Venezia

FRIDAY  
23.09.2022  
11.00 AM  
Conservatorio "Benedetto Marcello"  
Sala dei concerti  
LECTURE (50')  
Ondřej Adámek

4.00, 4.30, 5.00, 5.30 PM  
Arsenale – Teatro alle Tese (II)  
SOUND INSTALLATION  
**PAOLO BUONVINO**  
ÇIATU (30') \*\*\*  
Sound Installation  
Marco Lucarelli, light project  
Antonello Pocetti, mise en espace  
Production La Biennale di Venezia

8.00 PM  
Arsenale – Tese dei Soppalchi  
EXPERIMENTAL PERFORMANCE  
BIENNALE COLLEGE MUSICA -  
PERFORMER  
**TANIA CORTÉS**  
R I Z O M A, 2022 (30') \*\*\*  
for electronics and video  
Tania Cortés, performer  
**JACOPO CENNI**  
HUNT, 2022 (30') \*\*\*  
sound theatre for electronics  
and incandescent light bulbs  
Jacopo Cenni, performer  
Production La Biennale di Venezia,  
CIMM - Centro di Informatica Musicale  
Multimediale della Biennale di Venezia

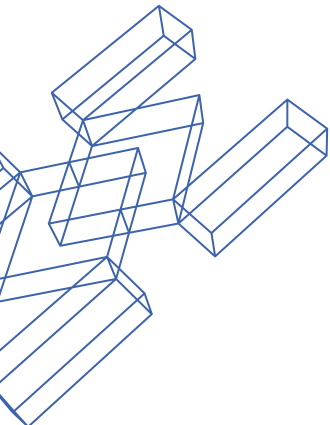

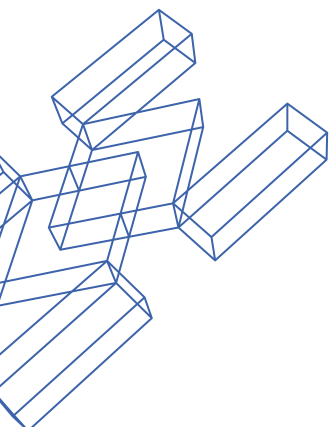

## SATURDAY

24.09.2022

9.00 AM

Ca' Giustinian – Sala delle Colonne

RADIO LIVE

Music Lessons RAI RADIO 3

Giovanni Bietti, presentation

**BRUNO MADERNA**

HYPERION

Teatro La Fenice, 1964 (30')

11.00 AM

Conservatorio "Benedetto Marcello"

Sala dei concerti

LECTURE (50')

Paolo Buonvino

4.00, 4.30, 5.00, 5.30 PM

Arsenale – Teatro alle Tese (II)

SOUND INSTALLATION

**PAOLO BUONVINO**

CIATU (30')

Sound Installation

Marco Lucarelli, light project

Antonello Pocetti, mise en espace

Production La Biennale di Venezia

6.00 PM

Teatro Piccolo Arsenale

EXPERIMENTAL MUSIC THEATRE

BIENNALE COLLEGE MUSICA -

COMPOSER

**TIMOTHY CAPE**

STILL DROWSY, 2022 (25') \*\*\*

performative music theatre for voice,

percussion trio, video and sound diffusion

Text collated by Timothy Cape

Esther-Elisabeth Rispens, soprano

Ars Ludi

Gianluca Ruggeri, Antonio Caggiano,

Rodolfo Rossi

**DANIIL POSAZHENNIKOV**

RELICT, 2022 (35') \*\*\*

linguistic mantram for voice,

percussion trio and electronics

Esther-Elisabeth Rispens, soprano

Ars Ludi

Gianluca Ruggeri, Antonio Caggiano,

Rodolfo Rossi

Daniil Posazhennikov, stage director

Egor Zaytsev, dramaturgy

Production La Biennale di Venezia,

CIMM - Centro di Informatica Musicale

Multimediale della Biennale di Venezia

9.00 PM

Scuola Grande di San Rocco

MADRIGALE RAPPRESENTATIVO

**ANNELIES VAN PARYS**

NOTWEHR, 2022 (50') \*\*\*

for two singers, vocal and instrumental

ensemble based upon *Barca di Venetia*

*per Padova - Dilettevoli Madrigali à cinque*

*Voci* by Adriano Banchieri, 1605, 1623

Libretto by Gaea Schoeters

Johanna Zimmer, soprano

Els Mondelaers, mezzo-soprano

VENETIAETERNA ensemble vocale

Silvia Porcellini, soprano

Elisabetta Cuman, mezzo-soprano

Miranda Ying Quan, contralto

Giacomo Schiavo, tenor

Francisco Augusto Bois, bass

Francesco Erle, conductor

HERMESensemble

Karin de Fleyt, flute

Stijn Saveniers, cello

Bram Fournier, trombone

Gaetan La Mela, percussion

Sjaron Minailo, mise en espace

Commission La Biennale di Venezia

Coproduction La Biennale di Venezia,

Studio Minailo, HERMESensemble,

Muziektheater Transparan

With support of the Flemish Government

# Out of stage

# BIENNALE MUSICA 2022

SUNDAY

25.09.2022

9.00 AM

Ca' Giustinian – Sala delle Colonne

RADIO LIVE

Music Lessons RAI RADIO 3

Giovanni Bietti, presentation

**LUIGI NONO**

INTOLLERANZA

Teatro La Fenice, 1961 (30')

11.00 AM

Ca' Giustinian – Sala delle Colonne

Award Ceremony of the Jury Prize

of Students from Italian Conservatories

Guido Barbieri, Coordinator of the Jury

(30')

2.00 > 4.00 PM

Fondazione Giorgio Cini – Sala Barbantini

ROUND TABLE

MUSIC THEATRE TODAY.

VOICES, ACTIONS, TECHNOLOGIES

coordinators:

Gianmario Borio (Fondazione Giorgio Cini,  
Università di Pavia),

Vincenzina Caterina Ottomano

(Università Ca' Foscari di Venezia)

Participants:

Robert Adlington

(University of Huddersfield),

Susanne Kogler (Universität Graz),

Giordano Ferrari (Université Paris 8),

Dorothea Hartmann (Deutsche Oper Berlin),

Koen Bollen (Opera Ballet Vlaanderen)

In collaboration with

Fondazione Giorgio Cini,

Università Ca' Foscari Venezia –

Dipartimento di Filosofia e Beni Culturali

4.00, 4.30, 5.00, 5.30 PM

Arsenale – Teatro alle Tese (II)

SOUND INSTALLATION

**PAOLO BUONVINO**

CIATU (30')

Sound Installation

Marco Lucarelli, light project

Antonello Pocetti, mise en espace

Production La Biennale di Venezia

8.00 PM

Arsenale – Teatro alle Tese (III)

EXPERIMENTAL MUSIC THEATRE

**GIORGIO BATTISTELLI**

EXPERIMENTUM MUNDI, 1981 (60')

Opera di musica immaginistica for one

actor, four women voices,

sixteen craftsmen and solo percussion

Libretto by Giorgio Battistelli

after the *Encyclopédie ou Dictionnaire*

*raisonné des sciences, des arts et des*

*métiers* by Denis Diderot

and Jean Le Rond D'Alembert

Peppe Servillo, actor

Nicola Raffone, percussions

Paola Calcagni, Flora Molle, Rosa Pulcini,

Anna Rita Severini, female voices

Alfredo Sannibale,

Fabio Sannibale, cooperages

Roberto Festuccia,

Alberto Casini, carpenters

Marcello Di Palma, pasta-maker

Oberdan Carpineti, Pietro Melelli, paviours

Ciro Paudice, Marco Carbone, bricklayers

Gianni Sannibale,

Marco Sannibale, blacksmiths

Aldo Sardilli, Luigi Battistelli, knife-grinders

Enzo Iezzi, Luigi Diotallevi, shoemakers

Francesco Campanella, stone-mason

Angelo Linzalata, light design

Giorgio Battistelli, conductor

CIMM - Centro di Informatica Musicale

Multimediale della Biennale di Venezia

Thierry Coduys, sound engineer

\*\*\* World premiere

\* Italian premiere

The program may vary



#### FREE SHUTTLE BOAT

From Arsenale  
to S. Elena – S. Zaccaria –  
Zattere – Tronchetto – P.le Roma  
after the evening shows

Snack bar service available (Arsenale)

#### TICKETS

tickets can be purchased online  
and one hour before the show at  
the ticket office on site

**LECTURES, ROUND TABLE  
GOLDEN AND SILVER LION  
AWARD CEREMONIES**

Free admission

**For information, prices  
and access regulations  
visit the website**

[www.labiennale.org](http://www.labiennale.org)  
[promozione@labiennale.org](mailto:promozione@labiennale.org)  
T. +39 041 5218 828

Media Partner