

BIENNALE MUSICA



La Biennale di Venezia

Arte
Architettura
Cinema
Danza
Musica
Teatro
Archivio Storico

Out of stage

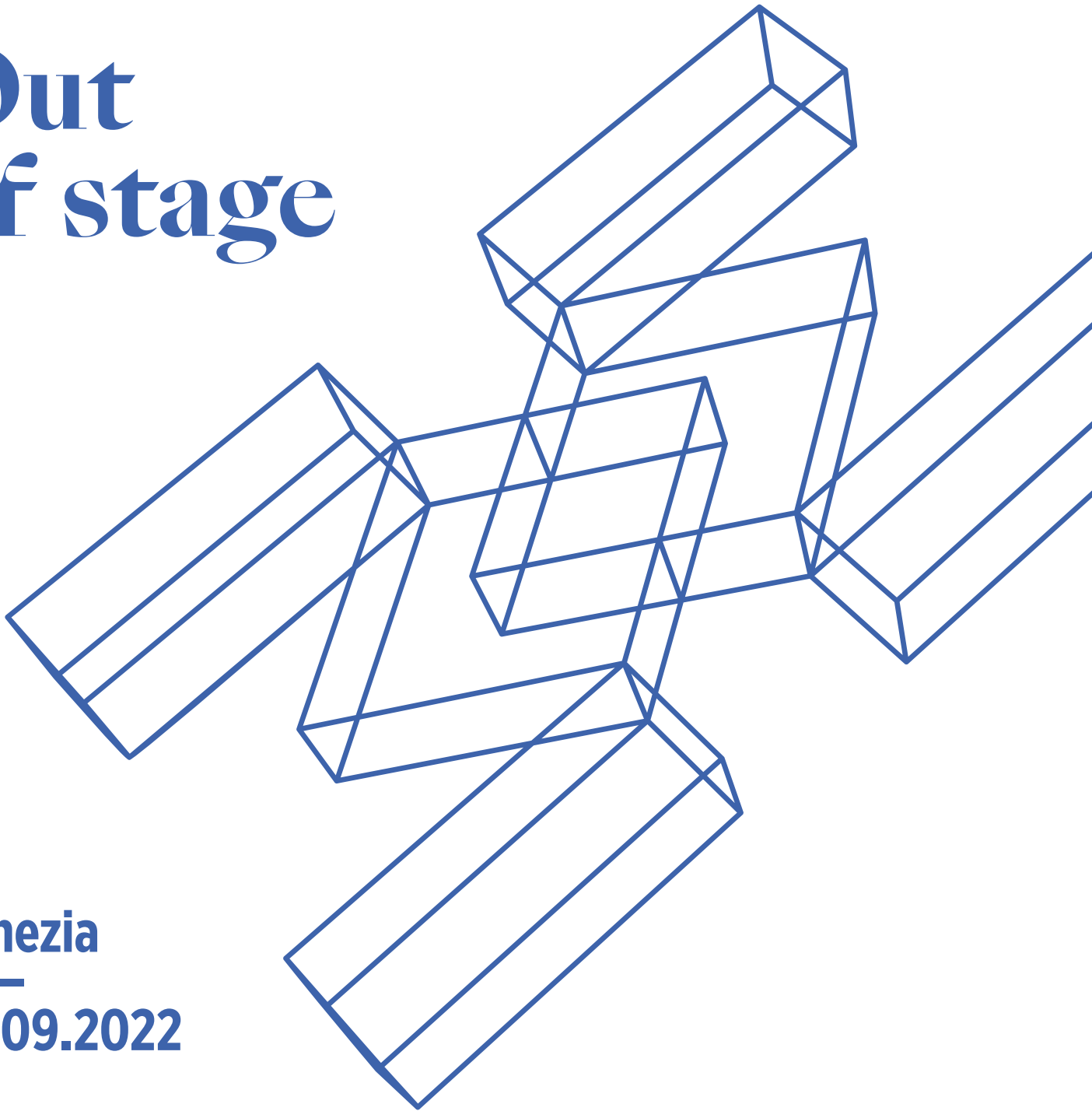

Venezia
14—
25.09.2022

#BiennaleMusica2022

-  La Biennale di Venezia
-  labiennale
-  la_Biennale
-  BiennaleChannel

labiennale.org

La Biennale di Venezia
Ca' Giustinian
San Marco 1364/A

Info:
T. +39 041 5218 828
promozione@labiennale.org



REGIONE DEL VENETO

WEDNESDAY

14.09.2022

8.00 PM

Teatro La Fenice

INSTRUMENTAL THEATRE

GIORGIO BATTISTELLI

JULES VERNE, 1984-85 (60') ***

Immaginazione in forma di spettacolo
for percussion trio, three voices,
trumpet and piano

Libretto by Giorgio Battistelli

Ars Ludi

Gianluca Ruggeri, Antonio Caggiano,
Rodolfo Rossi

Angelo Linzalata, set/light design

Giorgio Battistelli, stage director

CIMM - Centro di Informatica Musicale

Multimediale della Biennale di Venezia

Thierry Coduys, sound engineer

Production La Biennale di Venezia

In collaboration with

Fondazione Teatro La Fenice

THURSDAY

15.09.2022

12.00 PM

Ca' Giustinian - Sala delle Colonne

Award Ceremony

Golden Lion for Lifetime Achievement

GIORGIO BATTISTELLI

12.30

Helga de la Motte in dialogue
with Giorgio Battistelli (30')

5.00 PM

Arsenale - Sala d'Armi A

SOUND INSTALLATION

BIENNALE COLLEGE MUSICA

COMPOSER

PAUL HAUPTMEIER

DIAPHANOUS SOUND, 2022 (30') ***

Augmented reality sound installation

Production La Biennale di Venezia,

CIMM - Centro di Informatica Musicale

Multimediale della Biennale di Venezia

15>25.09.2022

8.00 PM

Arsenale - Teatro alle Tese (III)

EXPERIMENTAL MUSIC THEATRE

ONDŘEJ ADÁMEK

RINO MURAKAMI

REACHING OUT, 2022 (55') *

moving voices

ONDŘEJ ADÁMEK

KNOCK EARTH STONE DUST (20')

based on *Man Time Stone Time*

for six singers, two percussionists,

two dancers

Lyrics by Sjón (Sigurjón Birgir Sigurðsson)

RINO MURAKAMI

SALMON CROSSING (15')

for six singers, two percussionists,

two dancers

Text after *Sake no Uta*

(*Salmon Song*) by Keiko Oguro

ONDŘEJ ADÁMEK

SCHLAFEN GUT. WARM (20')

new version for six singers,

two performers, two dancers

Ondřej Adámek, Eric Oberdorff,

concept and staging

Jean-Gabriel Valot, light design

Marie Hoffmann, production

Ensemble N.E.S.E.V.E.N.

(Never Ending Searching for Exact Vocal

Expression and Nuances)

Olga Siemieńczuk, Shigeko Hata,

Landy Andriamboavonjy, Nicolas Simeha,

Steve Zheng, Paul-Alexandre Dubois,

voice, objects and movement

Compagnie Humaine

Cécile Robin Prévallée, Luc Bérad,

movement, objects

Jeanne Larroutou, Miguel Angel Garcia

Martin, instruments, objects and movement

Coproduction La Biennale di Venezia,

GMEM (Groupe de Musique Expérimental

de Marseille)-Centre national de création

musicale

10.30 PM

Ca' Giustinian - Sala delle Colonne

RADIO LIVE

Rai Radio3 - Il teatro di Radio3

BIENNALE COLLEGE MUSICA

COMPOSER

GEMMA RAGUÉS

VERITÀ A VENEZIA, 2022 (50') ***

performative radio composition

Gemma Ragués, vocal

and experimental performance

Production La Biennale di Venezia,

CIMM - Centro di Informatica Musicale

Multimediale della Biennale di Venezia

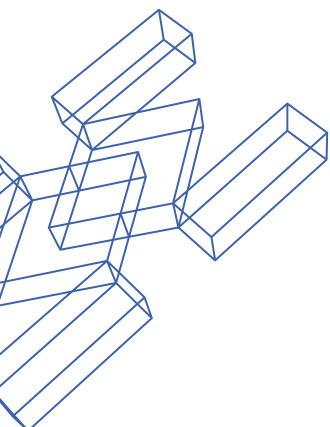

FRIDAY
16.09.2022
11.00 AM
Ca' Giustinian – Sala delle Colonne
LECTURE
NEW MUSIC THEATRE YESTERDAY,
TODAY AND TOMORROW (50')
Laura Berman, General Manager
and Artistic Director Staatsoper Hannover

7.00 PM
Teatro Piccolo Arsenale
EXPERIMENTAL MUSIC THEATRE
SIMON STEEN-ANDERSEN
THE RETURN
(a.k.a. Run Time Error @ Venice
feat. Monteverdi), 2022 (60') ***
Music theatre for three singers,
baroque ensemble, objects
and video based upon *Il ritorno
di Ulisse in patria* by Claudio Monteverdi
Text by Giacomo Badoaro
Giulia Bolcato, soprano
Anicio Zorzi Giustiniani, tenor
Davide Giangregorio, bass-baritone
VenEthos Ensemble
Fabiano Martignago,
Anna Chiara Mondin, recorder
Giacomo Catana, Mauro Spinazzè, violins
Francesco Lovato, viola
Leonardo Galligioni, doublebass
Simone Vallerotonda, thiorbo
Alberto Busettini, cembalo (also regal)
Massimo Raccanelli, cello and conductor
Simon Steen-Andersen, concept,
staging, mic- and joystick performer
Peter Tinning, camera performer
Ellen Rosand and Stefano Nardelli,
video interviews
Commission La Biennale di Venezia
Production La Biennale di Venezia
Thanks to VELA S.p.a e Comune
di Venezia, Venice Film Commission
for collaboration during shooting
in February

9.00 PM
Teatro del Parco – Mestre
EXPERIMENTAL PERFORMANCE
KLEIN
Performance for voice
and electronics (30') ***
DANIELE CARCASSI, X. LEE
PARALLAX (30') ***
Experimental performance
CIMM - Centro di Informatica Musicale
Multimediale della Biennale di Venezia
Production La Biennale di Venezia
In collaboration with
Settore Cultura Comune di Venezia

SATURDAY
17.09.2022
9.00 AM
Ca' Giustinian – Sala delle Colonne
RADIO LIVE
Music Lessons RAI RADIO 3
Giovanni Bietti, presentation
FRANCESCO CAVALLI
IL GIASONE
Teatro San Cassian, 1649 (30')

12.00 PM
Ca' Giustinian – Sala delle Colonne
Award Ceremony
Silver Lion
ARS LUDI
12.30 PM
Guido Barbieri in dialogue with Ars Ludi (30')

6.00 PM
Teatro Piccolo Arsenale
EXPERIMENTAL MUSIC THEATRE
SIMON STEEN-ANDERSEN
THE RETURN
(a.k.a. Run Time Error @ Venice
feat. Monteverdi), 2022 (60')

8.00 PM
Fondazione Giorgio Cini – Lo Squero
INSTRUMENTAL THEATRE
BIENNALE COLLEGE MUSICA
PERFORMER
Hosted by Tom Service (BBC Radio3)
FRANÇOIS SARHAN
SITUATION 4 – VICE VERSA
for two performers, 2010 (4')
Kathryn Vetter, Dafne Paris, performers

GEORGES APERGHIS
GRAFFITIS, 1981 (20')
for a percussionist
Federico Tramontana, percussion
SIX TOURBILLONS, 1989 (12')
for female voice
Esther-Elisabeth Rispens, soprano
TRYPTIQUE – FIDÉLITÉ (PART III), 1982 (16')
for harp
Dafne Paris, harp

SEPT CRIMES DE L'AMOUR –
FOR A MOVIE BY MICHEL FANO, 1979 (12')
for soprano, clarinet and percussion
Esther-Elisabeth Rispens, soprano
Kathryn Vetter, clarinet
Federico Tramontana, percussion

CAROLA BAUCKHOLT
HIRN & EI
(fragments of the score), 2010 (4')
for four performers
Dafne Paris, Esther-Elisabeth Rispens,
Kathryn Vetter, Federico Tramontana
Production La Biennale di Venezia

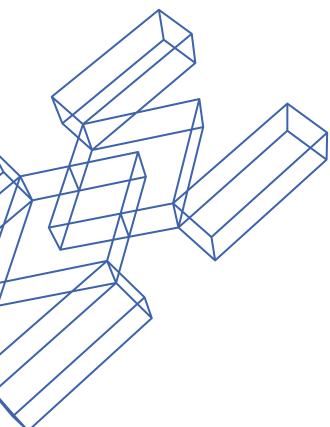

Out of stage

BIENNALE MUSICA 2022

SUNDAY
18.09.2022

9.00 AM
Ca' Giustinian – Sala delle Colonne
RADIO LIVE
Music Lessons RAI RADIO 3
Giovanni Bietti, presentation
ANTONIO VIVALDI
ORLANDO
Teatro dell'Angelo, 1727 (30')

11.00 AM
Conservatorio "Benedetto Marcello"
Sala dei concerti
LECTURE (50')
Simon Steen-Andersen

4.00 PM
Biblioteca Marciana – Salone Sansoviniano
PERFORMATIVE LECTURE
"Ad immitatione delle passioni" (30')
"Canto" and "declamato" between Florence
and Venice in early XVII Century
Texts by Claudio Monteverdi
and Giulio Caccini
Paolo Da Col, lecture
and vocal performance
INSTRUMENTAL THEATRE
MEHDI JALALI
UNFOLDING ***
Praying ritual for solo tanbur
Improvisation on maqâm by
Khan-Amiri, Sahari, Chupi-Razbaari,
Savar-Savar and Jelo-Shahi
RAGHS-E-SAMA
from KHAT-E-SEVOM, 2016
Mehdi Jalali, tanbur

8.00 PM
Arsenale – Tese dei Soppalchi
INSTRUMENTAL THEATRE
Hosted by Tom service (BBC Radio3)
MAURICIO KAGEL
DRESSUR, 1977 (30')
percussion trio for wooden instruments
Ars Ludi
Gianluca Ruggeri, Antonio Caggiano,
Rodolfo Rossi
GIORGIO BATTISTELLI
ORAZI E CURIAZI, 1996 (13')
for two percussionists
Ars Ludi
Gianluca Ruggeri, Antonio Caggiano

MONDAY
19.09.2022

11.00 AM
Conservatorio "Benedetto Marcello"
Sala dei concerti
LECTURE
THE FIRST EXPERIMENTAL
MUSIC THEATER: VENETIAN OPERA (50')
Ellen Rosand, Yale University

8.00 PM
Teatro Goldoni
EXPERIMENTAL MUSIC THEATRE
MICHEL VAN DER AA
THE BOOK OF WATER, 2022 (70') ***
music theatre for actor, string quartet
and film based upon *Der Mensch
erscheint im Holozän* by Max Frisch
adapted by Michel van der Aa
Geiser young (live), Samuel West
Geiser elderly (film), Timothy West
Corinne (soprano, film), Mary Bevan
String Quartet Ensemble Modern
Jagdish Mistry, Giorgos Panagiotidis, violins
Megumi Kasakawa, viola
Eva Böcker, cello
Michael van der Aa, composition,
stage director and script
Madelon Kooijman, dramaturgy
Bart van den Heuvel, light design
Djoere de Jong, production
Martijn van Nunen, Siemen van der Werf,
technical production
Norbert Ommer, sound director
(Ensemble Modern)
Commission La Biennale di Venezia, En-
semble Modern, Amsterdam Sinfonietta,
Muziekgebouw Amsterdam
Coproduction La Biennale di Venezia,
doubleAFoundation

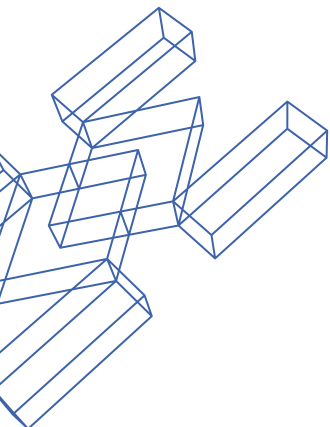

Out of stage

BIENNALE MUSICA 2022

TUESDAY

20.09.2022

11.00 AM

Conservatorio "Benedetto Marcello"
Sala dei concerti
LECTURE (50')
Michel van der Aa

6.00 PM

Ca' Giustinian – Sala delle Colonne
CHORAL MUSIC THEATRE
NATIVE AMERICAN INSPIRATIONS ***
A music drama in voice

BRENT MICHAEL DAVIDS

MOHICAN SOUP, 1997
NIGHT CHANT, 1996
CITY OF WATER, 2022
Commission Shenandoah Conservatory

RUSSELL WALLACE

JOURNEY, 2002, revised 2021

LOUIS BALLARD

MOHAVE BIRD DANCE SONGS, arr. 2003

DAWN Ieriho:kwats AVERY

TEIONKHIYA:TATON, 2022

JENNIFER STEVENS

BEGINNING OF TIME, 2022

Vocal Ensemble Students of Shenandoah
Conservatory & Shenandoah University
Matt Oltman, conductor
Ella Marchment, director
Coproduction La Biennale di Venezia,
Sala 1 – Centro Internazionale d'Arte
Contemporanea, Shenandoah Conservatory

9.00 PM

Teatro del Parco – Mestre
EXPERIMENTAL PERFORMANCE

YVETTE JANINE JACKSON

LEFT BEHIND (60') ***

A radio opera
Radio Opera Workshop Ensemble
Malesha Jessie Taylor, voice
Joy Guidry, bassoon
Amy Cimini, viola
Judith Hamann, cello
Tommy Babin, double bass
Yvette Janine Jackson, electronics
In collaboration with
Settore Cultura Comune di Venezia

WEDNESDAY

21.09.2022

11.00 AM

Conservatorio "Benedetto Marcello"
Sala dei concerti
LECTURE (50')
Yvette Janine Jackson

9.00 PM

Basilica di San Marco
SACRED REPRESENTATION

HELENA TULVE

VISIONS, 2022 (50') ***

for vocal ensemble, "cori spezzati"
and multiple instrumental ensembles
Text by Helena Tulve after fragments
of sacred representation found
by Giulio Cattin in Santa Maria della Fava
in 1994, and the Gospel of Mary Magdalene
Vox Clamantis
Jaan-Eik Tulve, conductor
Cappella Marciana
Marco Gemmani, conductor
Marco Ambrosini, Angela Ambrosini,
nyckelharpa
Anna-Liisa Eller, kannel, percussion
Ensemble barocco del Conservatorio
"Benedetto Marcello" di Venezia
Francesco Erle, conductor
Marius Peterson, stage director
Commission La Biennale di Venezia
Production La Biennale di Venezia
In collaboration with Basilica
e Procuratoria di San Marco

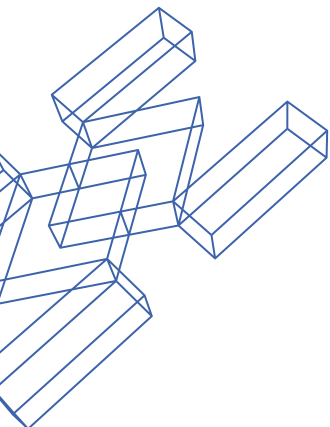

THURSDAY

22.09.2022

10.00 AM > 12.00 PM

Palazzo Giustinian Lolin – Sala Biblioteca

ROUND TABLE

GIULIO CATTIN'S CRITICAL RECONSTRUCTION OF THE 14TH-CENTURY LITURGICAL DRAMAS IN SANTA MARIA DELLA FAVA AND HELENA TULVE'S NEW COMPOSITIONAL TREATMENT
Helena Tulve

(Estonian Academy of Music and Theatre),
Roberto Calabretto (Fondazione Ugo e Olga Levi, Università di Udine),
Antonio Lovato (Università di Padova),
Francesco Erle (Conservatorio "Benedetto Marcello" di Venezia)
in collaboration with
Fondazione Ugo e Olga Levi

4.00, 6.00 AM

Arsenale – Sala d'Armi E

PERFORMATIVE SOUND INSTALLATION

ALEXANDER SCHUBERT

SLEEP LABORATORY, 2022 (50') *

Performative Installation for
musicians/performers and VR/360 Video
United Instruments of Lucilin

Sophie Deshayes, flute

Winnie Cheng, violin

Danielle Hennicot, viola

Ingrid Schoenlaub, cello

Pascal Meyer, piano

Guy Frisch, percussions

WE ARE VISUAL

Marc Einsiedel, Felix Jung, set

Multimedia Kontor Hamburg (MMKH)

Leonhard Onken Menke, Sebastian Olariu,
VR, 360 Video

Tobias Johannes Pfeil, co-development
and artistic collaboration

Felina Levits, costumes

Jonathan Harth, scientific adviser

Alexander Schubert, concept, stage director

Coproduction La Biennale di Venezia,

ACHT BRÜCKEN-Musik für Köln,

Philharmonie Luxemburg

(rainy days festival),

United Instruments of Lucilin

22.09 > 25.09.2022

12.00, 2.00, 4.00, 6.00 PM

8.00 PM

Arsenale – Teatro alle Tese (II)

EXPERIMENTAL MUSIC THEATRE

PAOLO BUONVINO

ÇIATU, 2022 (50') ***

for vocalists, disklaiviers, ensemble,
recorded voices and live electronics

Text by Paolo Buonvino

based on literary and documentary frag-
ments about the concept of breath in Sicily

PMCE - Parco della Musica

Contemporanea Ensemble

Manuel Zurria, flute

Paolo Ravaglia, clarinet

Francesco Peverini, Filippo Fattorini, violins

Luca Sanzò, viola

Anna Armatys, cello

Massimo Ceccarelli, doublebass

Flavio Tanzi, percussion

Paolo Buonvino, Yamaha C7X EN Disklavier

Yamaha Disklavier D U1 EN

Tonino Battista, conductor

Thierry Coduys, Paolo Buonvino,

Tommaso Cancellieri, sound design
and live electronics

Marco Lucarelli, light project

Antonello Pocetti, stage director

Commission La Biennale di Venezia

Production La Biennale di Venezia

FRIDAY

23.09.2022

11.00 AM

Conservatorio "Benedetto Marcello"

Sala dei concerti

LECTURE (50')

Ondřej Adámek

4.00, 4.30, 5.00, 5.30 PM

Arsenale – Teatro alle Tese (II)

SOUND INSTALLATION

PAOLO BUONVINO

ÇIATU (30') ***

Sound Installation

Marco Lucarelli, light project

Antonello Pocetti, mise en espace

Production La Biennale di Venezia

8.00 PM

Arsenale – Tese dei Soppalchi

EXPERIMENTAL PERFORMANCE

BIENNALE COLLEGE MUSICA -

PERFORMER

TANIA CORTÉS

R I Z O M A, 2022 (30') ***

for electronics and video

Tania Cortés, performer

JACOPO CENNI

HUNT, 2022 (30') ***

sound theatre for electronics

and incandescent light bulbs

Jacopo Cenni, performer

Production La Biennale di Venezia,

CIMM - Centro di Informatica Musicale

Multimediale della Biennale di Venezia

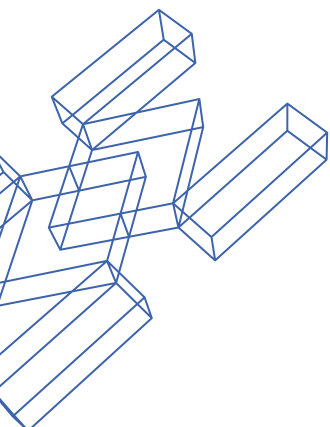

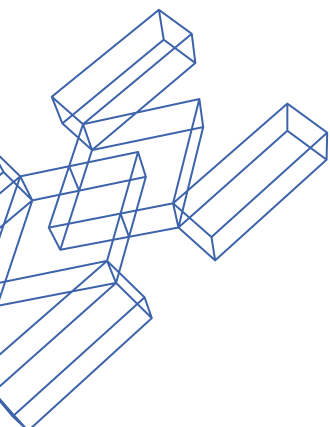

SATURDAY
24.09.2022

9.00 AM

Ca' Giustinian – Sala delle Colonne

RADIO LIVE

Music Lessons RAI RADIO 3

Giovanni Bietti, presentation

BRUNO MADERNA

HYPERION

Teatro La Fenice, 1964 (30')

11.00 AM

Conservatorio "Benedetto Marcello"

Sala dei concerti

LECTURE (50')

Paolo Buonvino

4.00, 4.30, 5.00, 5.30 PM

Arsenale – Teatro alle Tese (II)

SOUND INSTALLATION

PAOLO BUONVINO

CIATU (30')

Sound Installation

Marco Lucarelli, light project

Antonello Pocetti, mise en espace

Production La Biennale di Venezia

6.00 PM

Teatro Piccolo Arsenale

EXPERIMENTAL MUSIC THEATRE

BIENNALE COLLEGE MUSICA -

COMPOSER

TIMOTHY CAPE

STILL DROWSY, 2022 (25') ***

performative music theatre for voice,
percussion trio, video and sound diffusion

Text collated by Timothy Cape

Esther-Elisabeth Rispens, soprano

Ars Ludi

Gianluca Ruggeri, Antonio Caggiano,

Rodolfo Rossi

DANIIL POSAZHENNIKOV

RELICT, 2022 (35') ***

linguistic mantram for voice,
percussion trio and electronics

Esther-Elisabeth Rispens, soprano

Ars Ludi

Gianluca Ruggeri, Antonio Caggiano,

Rodolfo Rossi

Daniil Posazhennikov, stage director

Egor Zaytsev, dramaturgy

Production La Biennale di Venezia,

CIMM - Centro di Informatica Musicale

Multimediale della Biennale di Venezia

9.00 PM

Scuola Grande di San Rocco

MADRIGALE RAPPRESENTATIVO

ANNELIES VAN PARYS

NOTWEHR, 2022 (50') ***

for two singers, vocal and instrumental
ensemble based upon *Barca di Venetia
per Padova - Dilettevoli Madrigali à cinque
Voci* by Adriano Banchieri, 1605, 1623

Libretto by Gaea Schoeters

Johanna Zimmer, soprano

Els Mondelaers, mezzo-soprano

VENETIAETERNA ensemble vocale

Silvia Porcellini, soprano

Elisabetta Cuman, mezzo-soprano

Miranda Ying Quan, contralto

Giacomo Schiavo, tenor

Francisco Augusto Bois, bass

Francesco Erle, conductor

HERMESensemble

Karin de Fleyt, flute

Stijn Saveniers, cello

Bram Fournier, trombone

Gaetan La Mela, percussion

Sjaron Minailo, mise en espace

Commission La Biennale di Venezia

Coproduction La Biennale di Venezia,

Studio Minailo, HERMESensemble

SUNDAY
25.09.2022

9.00 AM

Ca' Giustinian – Sala delle Colonne

RADIO LIVE

Music Lessons RAI RADIO 3

Giovanni Bietti, presentation

LUIGI NONO

INTOLLERANZA

Teatro La Fenice, 1961 (30')

11.00 AM

Ca' Giustinian – Sala delle Colonne

Award Ceremony of the Jury Prize

of Students from Italian Conservatories

Guido Barbieri, Coordinator of the Jury

(30')

2.00 > 4.00 PM

Fondazione Giorgio Cini – Sala Barbantini

ROUND TABLE

MUSIC THEATRE TODAY.

VOICES, ACTIONS, TECHNOLOGIES

coordinators:

Gianmario Borio (Fondazione Giorgio Cini,

Università di Pavia),

Vincenzina Caterina Ottomano

(Università Ca' Foscari di Venezia)

Participants:

Robert Adlington

(University of Huddersfield),

Susanne Kogler (Universität Graz),

Giordano Ferrari (Université Paris 8),

Dorothea Hartmann (Deutsche Oper Berlin),

Koen Bollen (Opera Ballet Vlaanderen)

In collaboration with

Fondazione Giorgio Cini,

Università Ca' Foscari Venezia –

Dipartimento di Filosofia e Beni Culturali

4.00, 4.30, 5.00, 5.30 PM

Arsenale – Teatro alle Tese (II)

SOUND INSTALLATION

PAOLO BUONVINO

CIATU (30')

Sound Installation

Marco Lucarelli, light project

Antonello Pocetti, mise en espace

Production La Biennale di Venezia

8.00 PM

Arsenale – Teatro alle Tese (III)

EXPERIMENTAL MUSIC THEATRE

GIORGIO BATTISTELLI

EXPERIMENTUM MUNDI, 1981 (60')

Opera di musica immaginistica for one

actor, four women voices,

sixteen craftsmen and solo percussion

Libretto by Giorgio Battistelli

after the *Encyclopédie ou Dictionnaire*

raisonné des sciences, des arts et des

métiers by Denis Diderot

and Jean Le Rond D'Alembert

Peppe Servillo, actor

Nicola Raffone, percussions

Paola Calcagni, Flora Molle, Rosa Pulcini,

Anna Rita Severini, female voices

Alfredo Sannibale,

Fabio Sannibale, cooperages

Roberto Festuccia,

Alberto Casini, carpenters

Marcello Di Palma, pasta-maker

Oberdan Carpineti, Pietro Melelli, paviours

Ciro Paudice, Marco Carbone, bricklayers

Gianni Sannibale,

Marco Sannibale, blacksmiths

Aldo Sardilli, Luigi Battistelli, knife-grinders

Enzo Iezzi, Luigi Diotallevi, shoemakers

Francesco Campanella, stone-mason

Angelo Linzalata, light design

Giorgio Battistelli, conductor

CIMM - Centro di Informatica Musicale

Multimediale della Biennale di Venezia

Thierry Coduys, sound engineer

*** World premiere

* Italian premiere

The program may vary



FREE SHUTTLE BOAT

From Arsenale
to S. Elena – S. Zaccaria –
Zattere – Tronchetto – P.le Roma
after the evening shows

Snack bar service available (Arsenale)

TICKETS

tickets can be purchased online
and one hour before the show at
the ticket office on site

**LECTURES, ROUND TABLE
GOLDEN AND SILVER LION
AWARD CEREMONIES**

Free admission

**For information, prices
and access regulations
visit the website**

www.labiennale.org
promozione@labiennale.org
T. +39 041 5218 828

Media Partner