



La Biennale di Venezia

Archivio Storico  
della Biennale  
di Venezia

125

# LE MUSE INQUIETE

WHEN  
LA BIENNALE  
DI VENEZIA  
MEETS HISTORY

CENTRAL PAVILION,  
GIARDINI DELLA BIENNALE  
29.08 – 8.12.2020

## **La Biennale di Venezia**

presents

### **The Disquieted Muses. When La Biennale di Venezia Meets History**

*in collaboration with*

Istituto Luce-Cinecittà e Rai Teche

*and with*

AAMOD-Fondazione Archivio Audiovisivo

del Movimento Operaio e Democratico

Archivio Centrale dello Stato

Archivio Ugo Mulas

Bianconero Archivio Cameraphoto Epoche

Fondazione Modena Arti Visive

Galleria Nazionale d'Arte Moderna e Contemporanea

IVESER Istituto Veneziano per la Storia della Resistenza

e della Società Contemporanea

LIMA Amsterdam

Peggy Guggenheim Collection

Tate Modern

## **La Biennale di Venezia**

### **President**

Roberto Cicutto

### **Board**

Luigi Brugnaro **Vicepresidente**

Claudia Ferrazzi

Luca Zaia

### **Auditors' Committee**

Jair Lorenzo **Presidente**

Stefania Bortoletti

Anna Maria Como

### **Director General**

Andrea Del Mercato

# THE DISQUIETED MUSES...

The title of the exhibition *The Disquieted Muses. When La Biennale di Venezia Meets History* does not just convey the content that visitors to the Central Pavilion in the Giardini della Biennale will encounter, but also a vision.

Disquiet serves as a driving force behind research, which requires dialogue to verify its theories and needs history to absorb knowledge. This is what La Biennale does and will continue to do as it seeks to reinforce a methodology that creates even stronger bonds between its own disciplines.

There are six Muses at the Biennale: Art, Architecture, Cinema, Theatre, Music and Dance, given a voice through the great events that fill Venice and the world every year.

There are the places that serve as venues for all of La Biennale's activities: the Giardini, the Arsenale, the Palazzo del Cinema and other cinemas on the Lido, the theatres, the city of Venice itself. But there is also one place where, when the exhibitions and festivals are over, the research continues and opens out onto the world: the Historical Archives of Contemporary Arts (ASAC). This is a place where knowledge is consolidated over time, where it becomes permanent and extends beyond the limited timeframe of the exhibitions. The exhibition that opens on 29 August is an important step in this process, a new beginning, a shared experience and a search for common goals. The six current artistic directors and those who will come after them are well aware that their work (which is often prescient and visionary) must endure over time, assisted by the unparalleled capabilities of new digital technologies. An archive preserves, restores, and keeps guard over the years so that its content may always be available for use in the best possible condition and it can finally present to the world the wealth of what it holds, consisting in the work of artists, curators, specialists and scholars, or even ordinary visitors.

I would like to thank Cecilia Alemani, Hashim Sarkis, Alberto Barbera, Antonio Latella, Ivan Fedele and Marie Chouinard for accepting this particularly difficult challenge, carried out in record time and under complex circumstances. And I would like to thank the ASAC in its entirety and La Biennale team for embracing this adventure with such enthusiasm.

Roberto Cicutto

President of La Biennale di Venezia

# LE MUSE INQUIETE (THE DISQUIETED MUSES). WHEN LA BIENNALE DI VENEZIA MEETS HISTORY

The exhibition *Le muse inquiete* (*The Disquieted Muses*) takes us on a journey through the archive of La Biennale di Venezia, focusing on key moments when the wars, upheavals, generational conflicts and profound cultural transformations of the twentieth century reshaped the boundaries of this Venetian institution. In a period of global instability that over the course of just a few months has brought a succession of environmental disasters, new pandemics, and social revolutions, La Biennale di Venezia serves as a wellspring and channel for the most innovative currents in the artistic disciplines of our era – but also continues to bear witness to the many shifts and crises that have supervened from the late nineteenth century to the present, like a seismometer recording the tremors of history.

Over its 125 years of activity, La Biennale di Venezia has come face to face with history in some of its most dramatic incarnations. As an arena for diplomatic manoeuvres and political alliances in the first half of the twentieth century, La Biennale was visited by monarchs, dictators, heads of state, and revolutionaries, but also hosted protests and celebrations in which the arts echoed cultural paradigm shifts and changing mores. In 1920 and 1948 La Biennale rose from the ashes of two devastating world wars, standing as a beacon of hope for the rebirth of civil society in Italy and other nations. In the 1960s and '70s the Venetian institution was rocked by a wave of social and political transformations that redefined the relationship between the individual and the masses, as well as the power dynamics of the East, West, and Global South. In the '90s, after the collapse of the Cold War blocs, La Biennale adopted new artistic languages that ushered in a more global outlook and opened its doors to new geopolitical influences. Decade by decade, La Biennale also reflected changes in taste and in the bounds of propriety, amid scandals, episodes of censorship, and new mappings of desire.

The exhibition *Le muse inquiete* showcases historical documents, archive materials, photographs, rare documentary film and artworks from the prestigious historical archives of ASAC (founded in 1928) and other Italian collections and institutions, casting light on La Biennale's past and the way it has intersected with global events, illustrating and generating institutional ruptures, political and ethical crises and also new creative idioms.

The exhibition's title is a reference to the Muses: the Greek goddesses, daughters of Zeus and Mnemosyne, who embody the various artistic disciplines and serve here as a metaphor for the Biennale's six departments: the Visual Arts, Architecture, Cinema, Dance, Music and Theatre. As the daughters of memory, the muses looked back to the past, but also imagined new worlds and new possibilities through the power of artistic creation. The title is also a reference to the famous Giorgio de Chirico painting *Le muse inquietanti* (*The Disquieting Muses*, 1916), exhibited at the 24th International Art Exhibition in 1948. In this exhibition the muses are *disquieted* because they are grappling with the world outside the confines of art.

*Le muse inquiete* is the first exhibition in the history of La Biennale to be conceived at the intersection of the six disciplines that are its main spheres of experimentation, bringing episodes in its past into dialogue with the events of the twentieth century, and retracing key moments when La Biennale crossed paths with history in Venice. CA

## Entrance

- 1 Poster for the First International Art Exhibition of the City of Venice 1895
- 2 Poster for the 1st International Art Exhibition of the City of Venice 1895. Feste Veneziane
- 3 Augusto Sezanne  
Graphic project (1895-1897 ca.) for the International Art Exhibition  
Ink and tempera on paper  
69.5x69.5 cm
- 4 Augusto Sezanne  
Leone "Moleca" (1895-1897 ca.)  
China ink on paper  
32x21.8 cm.
- 5 Fist delivery for the institution of the International Art Exhibition of the City of Venice, 1893

# THE STATUTES OF LA BIENNALE DI VENEZIA

## Origins

La Biennale was founded in 1893 as a local public institution with the mission of organising international art exhibitions, which from the very start were meant to be recurring. The first International Art Exhibition of the City of Venice was held in 1895. The secretary general kept up contacts with delegates from participating countries to ensure a unified approach and overall artistic direction, providing the president with a suggested list of artists and works to be exhibited, including those to be shown in the “regional halls” (featuring Italian art) and “foreign halls” (with art from other nations). The exhibition was divided into two parts, as Paolo Baratta highlighted in his introduction to the yearbook that retraces the history of Biennale Arte: “the dualism between the exhibition of invited artists and the showcase of work accepted by the jury was a feature of La Biennale’s life for many years, effectively until 1956” (Note 1). Together with the subsequent creation of a sales office (which remained operational until 1968, before being turned into a “sales service” and then removed definitively in 1973), this aspect made for the clear primacy of Italian artists and was among the factors that determined the significant influence of artist unions in the life of La Biennale. The art exhibition was held in the Central Pavilion, called Pro Arte. Starting in 1907, for many years, national pavilions were built in the Giardini by participating countries. In 1928 the historical archive called Istituto Storico d’Arte Contemporanea and later (after 1930) as Archivio Storico delle Arti Contemporanee – ASAC was created here.

In 1930, with Royal Decree Law no. 33 of 13 January 1930, La Biennale was turned into a state-controlled body. Rather than a straightforward organisation set up to hold art exhibitions, it became an institution with a vast array of duties: in 1930 the music department was established and in 1932 the first Venice Film Festival was held, soon followed by the Theatre Festival in 1934. With a further reform of the statute in 1938 (Royal Decree Law no. 1517 of 21/07/38), this new dimension and wider responsibilities were confirmed. After an earlier transformation, the Central Pavilion’s facade was redone in 1932 and it was renamed Padiglione Italia, in keeping with the political ideology of a regime whose aim was to make the Biennale first a tool of intense cultural diplomacy, and then of nationalist aspirations to hegemony (Note 2).

## From the 1970s to the 1998 reform

A reform to the statute was debated in the late 1960s and partially enacted in 1973 (Law no. 438 of 26/7/1973); though welcomed as a great step forward, it did not ultimately turn out to be such. The change expanded its representative organs, adding administrative representatives from the government and the management (which had been state-run for some time) and political representatives from elected local bodies, as well as trade union representatives. The board of directors thus came to be made up of eighteen members (Note 3). Uncertainties and a lack of continuity led to demands for further reform and, in 1998, Legislative Decree no. 19 of 29 January 1998 transformed La Biennale di Venezia from a state-controlled public body into one that was public yet governed by private law, with a great deal of autonomy, a corporate structure, and private-sector employment contracts (the standard collective agreements used in commerce). It was headed by a president and a board of directors made up of just five members. A further amendment to the statute (Legislative Decree no. 1 of 8 January 2004) confirmed this reform, changing the organisation’s name from “Società di Cultura La Biennale di Venezia” to “Fondazione La Biennale di Venezia”. Following on from the 1998 reform two further policies were adopted: the event was to consist of a single international exhibition overseen by a sole curator, flanked by the pavilions of the various participating countries; it was also to be equipped with new spaces for its “own” exhibition and for new countries that did not have pavilions. Structurally speaking, it was to have two vast permanent spaces. The first would be the white-walled Central Pavilion, supplemented over the years by various public services and the ASAC library; the second would be the historic Arsenale, an exhibition structure with unique architecture that would also include important spaces for the Biennale College services and activities. As part of the new layout, a new Padiglione Italia was built in the midst of the Arsenale pavilions, to host the Italian projects curated by MiBACT. DR

1. See *Un excursus sulla Biennale Arte 1895-2019* in *Esposizione Internazionale d’Arte La Biennale di Venezia 1895-2019*, La Biennale di Venezia, Venezia 2019.

2. See *Diplomazia culturale*, cit.

3. See *Gli anni Settanta, lo statuto del 1973*, cit.

# ROOM 1

## THE FILM FESTIVAL 1932 - 1939

1932 marked the first Venice International Film Festival, which was established for very clear reasons. In the 1920s La Biennale President Giuseppe Volpi Conte di Misurata (1877-1947), who was Mussolini's finance minister, and Vittorio Cini, a powerful captain of industry, drew up a development plan for Venice. It was no longer to be a perfect whole, but divided up into distinct economic development districts: the Lido as the fashionable beach, Marghera as the industrial hub, and the historic centre as the tourist attraction. After the Wall Street Crash of 1929, tourism languished and Venice's hotels, including Volpi's own Excelsior, needed a boost. In the space of a few weeks, Antonio Maraini, secretary general of La Biennale di Venezia and a close confidant of the prominent Fascist Achille Starace, together with Luciano De Feo, director of the Istituto Internazionale per la Cinematografia Educativa (International Institute for Educational Cinematography), launched the first film festival in history on Hotel Excelsior's seafront terrace. The Fascist regime still had no full-blown plan for the cinema and thought of the festival just as a seaside social event. The Duce resisted attempts to persuade him to join the event's honorary committee or grant it official patronage, and the first Venice International Film Festival was largely funded by Volpi's own hotel company, Compagnia Italiana Grandi Alberghi. The event did not remain a no-man's-land for long, however, and was gradually brought into the Fascist fold. As early as 1935 the uniformed Fascist leaders began to arrive and "Coppa Mussolini" awards were handed out by the Associazione Nazionale Fascista (National Fascist Association). In 1934, Adolf Hitler visited the 19th International Art Exhibition, but left the film starlets to Joseph Goebbels, the Third Reich's propaganda minister, who came to the Lido in 1936. Goebbels attended the exhibition every year, making it one of the key events that strengthened the alliance between Rome and Berlin. It was clearly no coincidence that the "Mussolini Cup" was won by pro-regime films such as Augusto Genina's *Lo*

*squadrone bianco* (1936), Luis Trenker's *Der Kaiser von Kalifornien* (1936), Carmine Gallone's *Scipione l'Africano* (1937), Leni Riefenstahl's *Olympia* (1938), and Goffredo Alessandrini's *Luciano Serra pilota* (1938) and *Abuna Messias* (1939).

Despite the regime's favouritism towards Italian and German films, which in 1939 kept the Americans from attending, and despite the official speeches by Minister Dino Alfieri, festival directors Luciano De Feo and Attilio Fontana (1932-34) and Ottavio Croze (1935-1942) managed to bring films such as Ernst Lubitsch's *The Man I Killed / Broken Lullaby* (1932), Nikolai Ekk's *Putyovka v zhizn* (1932), Robert J. Flaherty's *Man of Aran* (1934), John Ford's *The Informer* (1935), Jean Renoir's *La Grande Illusion* (1937), Michael Powell's *The Edge of the World* (1937) and Marcel Carné's *Quai des brumes* (1938) to the Festival. GG

## Screen 1.1

Istituto Luce newsreels. Istituto Luce

The meeting of Mussolini and Hitler in Venice in 1934

Joseph Goebbels visiting the IV. Venice International Film Festival 1936 and the V. Venice International Film Festival 1937. Istituto Luce

Opening of the V. Venice International Film Festival 1937. Istituto Luce

## Screen 1.2

Istituto Luce newsreels. Istituto Luce

The Lido di Venezia in the Thirties. Istituto Luce

## Screen 1.3

Clip of some films presented at the Venice International Film Festivals between 1932 and 1939

*Extase* by Gustav Machatý, 1934

*À nous la liberté* by René Clair, 1932

*Triumph des Willens* by Leni Riefenstahl, 1935

*La Kermesse héroïque* by Jacques Feyder, 1936

*La Grande illusion* by Jean Renoir, 1937

*Olympia* by Leni Riefenstahl, 1938

*Luciano Serra Pilota* by Goffredo Alessandrini, 1938

## Screen 1.4

Hotel Excelsior – Giardino delle Fontane Luminose, 1934. Photo Studio Giacomelli

Actors on the terrace of the Hotel Excelsior, 1936. Photo Studio Ferruzzi

The Minister of Popular Culture Dino Alfieri visiting with Giuseppe Volpi di Misurata, 1936. Photo Studio Ferruzzi

The Minister of Popular Culture Dino Alfieri, 1937. Photo Studio Ferruzzi

The Minister of Popular Culture Dino Alfieri with the Prefect Giuseppe Carlo Catalano and some members of the International Jury, 1937. Istituto Luce, Photo Library

Raniero Paulucci di Calboli, director Luis Trenker, Laura Nucci outside the Palazzo del Cinema di Venezia at the screening of the film *Condottieri*, 1937. Istituto Luce, Photo Library

Raniero Paulucci di Calboli, Giuseppe Volpi di Misurata, Luis Trenker, Laura Nucci, Loris Gizzi and Osvald Lehnich at the first screening of the film *Condottieri*, 1937. Istituto Luce, Photo Library

Exterior of the Palazzo del Cinema di Venezia at night, 1937. Istituto Luce, Photo Library

Laura Nucci and Nives Poli with the President of the Enic, Raniero Paulucci di Calboli, at the beach of the Lido di Venezia, 1937. Istituto Luce, Photo Library

Raniero Paulucci di Calboli with Luis Trenker and Laura Nucci, 1937. Istituto Luce, Photo Library

Luis Trenker at the entrance hall of the Palazzo del Cinema with the Director of the Festival Ottavio Croze, 1937. Istituto Luce, Photo Library

A group of young people observing the advertising posters of the films in competition, 1938. Istituto Luce, Photo Library

The Minister of Popular Culture Dino Alfieri, 1937. Photo Studio Giacomelli

Giuseppe Volpi di Misurata and the Minister of Popular Culture Dino Alfieri, 1937. Photo Farabola

The Minister of Popular Culture Dino Alfieri, 1937. Photo Studio Ferruzzi

Giuseppe Volpi di Misurata and Antonio Maraini, 1937. Photo Studio Ferruzzi

King Vittorio Emanuele III with Giuseppe Volpi di Misurata, 1937

King Vittorio Emanuele III, 1937

Joseph Goebbels and Giuseppe Volpi di Misurata, 1939. Photo Publifoto

## Screen 1.5

Photographs of images extracted from the movies presented at the Venice International Film Festivals

*Grand Hotel* by Edmund Goulding, 1932

*Putěvka v žizn'* by Nikolaj Ěkk, 1932

*Strange Interlude* by Robert Z. Leonard, 1932

*The Champ* by King Vidor, 1932

*The Man I Killed/The Broken Lullaby* by Ernst Lubitsch, 1932

*Dr. Jekyll and Mr. Hyde* by Rouben Mamoulian, 1932

*Mädchen in Uniform* by Leontine Sagan, 1932

*The Private Life of Don Juan* by Alexander Korda, 1934

*Řeka* by Josef Rovenský, 1934

*Queen Christina* by Rouben Mamoulian, 1934

*Anna Karenina* by Clarence Brown, 1935

*Scrooge* by Henry Edwards, 1936

*Jánošík* by Martin Frič, 1936

*The Ghost Goes West* by René Clair, 1936

*Der Kaiser von Kalifornien* by Luis Trenker, 1936

*Le Perles de la couronne* by Sacha Guitry, 1937

*Pygmalion* by Anthony Asquith and Leslie Howard, 1938

*Olympia* by Leni Riefenstahl, 1938

*Panensství* by Otakar Vávra, 1938

*Jezebel* by William Wyler, 1938

*The Four Feathers* by Zoltan Korda, 1939

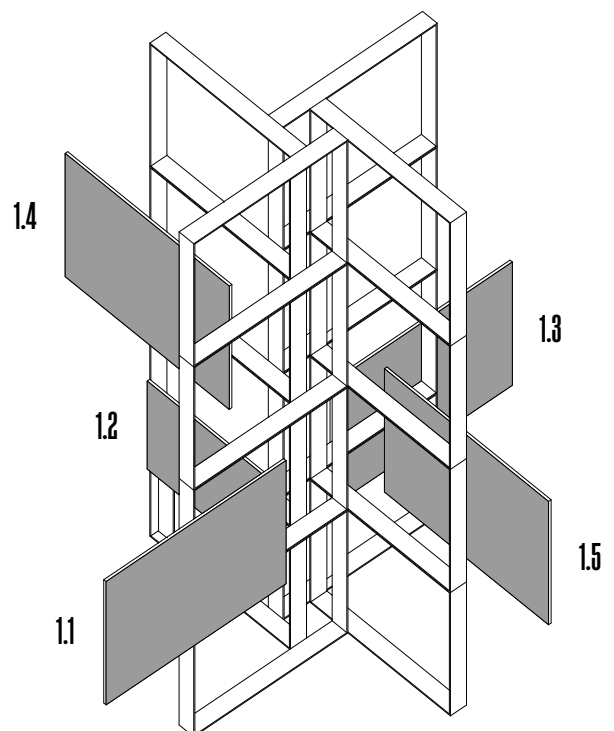

# ROOM 2A

## LA BIENNALE DURING FASCISM, 1928 - 1945

On 1 March 1927 La Biennale di Venezia appointed a new secretary general, the Florentine sculptor and art critic Antonio Maraini, to replace Vittorio Pica, who had overseen the postwar editions (1920, 1922, 1924 and 1926). Maraini asked various influential friends – Ugo Ojetti, Margherita Sarfatti and Marcello Piacentini – to assist him in organising the exhibition. Maraini’s familiarity with the Italian artistic milieu enabled him to bring artists such as Massimo Campigli, Carlo Carrà, Felice Casorati, Virgilio Guidi, Tullio Garbari, Pio Semeghini, Gino Severini, Mario Sironi, Ardengo Soffici, Alberto Tosi, Lorenzo Viani, Arturo Martini, Marino Marini and Giorgio Morandi into the limelight. Internationally speaking, important artists such as Georges Rouault, Édouard Vuillard, Suzanne Valadon, Maurice de Vlaminck, Marc Chagall, Max Beckmann, Otto Dix, Emil Nolde, Paul Klee and Piet Mondrian were shown at the Biennale, many for the first time. Maraini’s first edition, the 16th International Art Exhibition, closed on 4 November 1928 as an overall success, given the significant attendance and excellent critical response. In 1928 Maraini inaugurated the Istituto Storico d’Arte Contemporanea (La Biennale’s archives) at the Palazzo Ducale, transforming La Biennale di Venezia from a straightforward exhibition organiser to a cultural institution with many functions. This was part of a wider Fascist government plan for creating major cultural institutions, such as the Istituto per l’Enciclopedia Italiana (Institute for the Italian Encyclopedia), Reale Accademia d’Italia (Royal Italian Academy) and Istituto Nazionale Fascista di Cultura (National Fascist Institute of Culture), and showed the Fascist propensity to view the arts as a political propaganda tool. On 13 January 1930 the Biennale was made independent and its name was changed from the “International Art Exhibition of the City of Venice” to the “International Contemporary Art Exhibition”. Its board was reduced to just five members, including the president and a secretary general. The president was no longer to be Venice’s mayor, and the Venetian industrialist Giuseppe Volpi, Count of Misurata and a

former finance minister in the Mussolini government, was appointed instead. From 1930 onwards the Biennale was a fully Fascist organisation. Maraini’s ambition was to make Venice an international art centre, a “Geneva of the arts”. To this end he invited new nations to build national pavilions in the Giardini, as the United States did in 1930. On the other hand, he worked to increase acceptance and recognition of Italian art internationally, promoting a great many exhibitions abroad. In these same years, Maraini added three sectors to La Biennale – music, cinema and theatre – each with their own events: the Festival of Contemporary Music in 1930, the Venice Film Festival in 1932, and the Theatre Festival in 1934. VP



# ROOM 2A

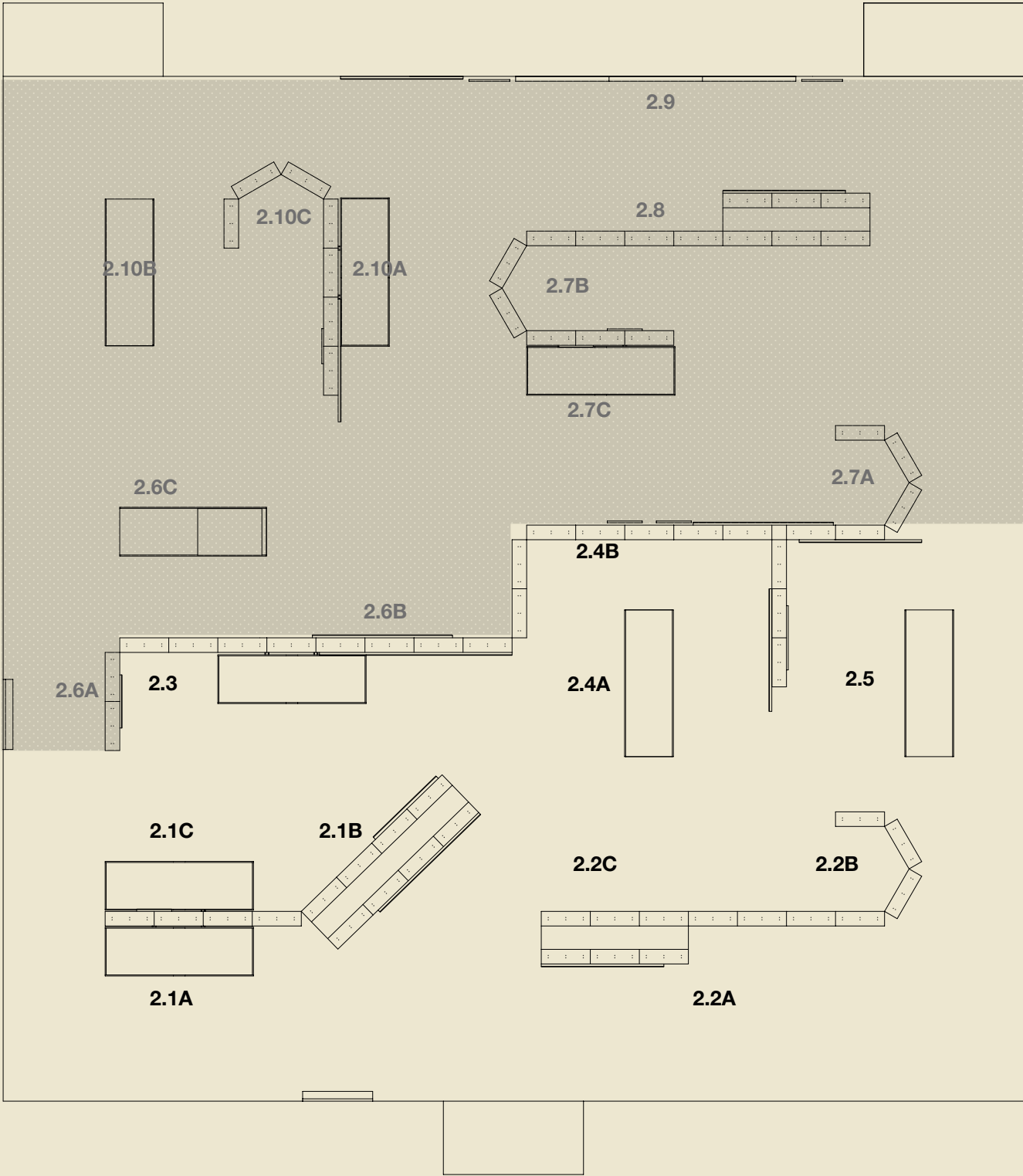

## 2.1 Secretary General Antonio Maraini

Antonio Maraini (1886-1963) began interweaving his own history with that of the Venice Biennale early on. In 1924 his sculptures were showcased at the Giardini with a solo room holding forty-eight works. They were presented in the catalogue by Lionello Venturi. On the other hand, as an art critic he contributed regularly to periodicals such as *Domus*, *Dedalo*, *La Ronda*, *L'Illustrazione italiana* and *The Studio*. In 1926 he was appointed to the board of La Biennale at the recommendation of Venetian writer and politician Pompeo Gherardo Molmenti and then, in 1927, was offered the post of secretary general. He set to work right away: in July 1927 he wrote a report to the president (mayor Pietro Orsi) in which, on one hand, he insisted on the need to keep his Biennale work temporary – i.e. limited to one year – whilst on the other he highlighted the continuity he saw as important for the institution. In 1929 Venice's new mayor Ettore Zorzi immediately took issue with Maraini, blaming him, in particular, for a municipal budget deficit of around 1,100,000 lire due to renovation work on the exhibition buildings. To defend himself from this criticism, Maraini sought support in Rome, and on 2 February 1929 a message reached Mussolini's office: "Maraini, who very recently joined the Fascist Party, would appear to be a man of irreproachable moral and political conduct". His appointment as La Biennale's secretary general was thus confirmed. From 1930 onwards, with its institutional independence and Giuseppe Volpi di Misurata's presidency, it was legally recognised as Italy's primary state exhibition. In addition to the decorative arts exhibitions which had been transferred from Monza to Milan in 1927 (the Triennale), a national contemporary art exhibition was being planned for Rome which was to have been the Biennale's great rival, the Quadriennale. Maraini succeeded in controlling these rival institutions from within, thanks to his new appointment as president of the *Sindacato Nazionale Fascista delle Belle Arti* (National Fascist Union of the Fine Arts), officialised in 1932. In the spring of 1929 Maraini took part in the first Biennale exhibition abroad, a showcase in Nice of the "Novecento Italiano" movement promoted by Margherita Sarfatti. 1932 was another watershed in the life of the Biennale, which was now the linchpin for organising a great many activities. In addition to the 18th International Art Exhibition the biggest news was the inauguration of the Venice Pavilion for the applied arts. In these same months the Biennale hosted its First International Congress of Contemporary Art, held its first poetry conference, and introduced the Premio del Gondoliere prize, won by Giuseppe Ungaretti. VP

### 2.1A The Biennale Arte, 1927 - 1932

Maraini's first step in his modernisation plans for La Biennale was to summon architects – whose work was thus featured for the first time alongside that of painters and sculptors – to renovate and redesign the Palazzo dell'Esposizione. The secretary commissioned Gio Ponti to build the modern dome over Galileo Chini's frescoes; Marcello Piacentini to modernise the main

space, the Salone delle Feste; and Brenno del Giudice to add a terrace coffee bar overlooking the Sant'Elena canal. Maraini also came up with the idea of using the Palazzo dell'Esposizione to house a series of exhibitions, each of them curated by a different art critic: the theatre arts exhibition was entrusted to Margherita Sarfatti, the nineteenth-century Italian painting exhibition to Ugo Ojetti, and the School of Paris exhibition to René Paresce. Maraini's attention to exhibition design led him to set aside certain rooms for the decorative arts, for the first time in La Biennale's history. The roofing over of the Art Nouveau frescoes that had decorated the octagonal Palazzo dell'Esposizione since 1909 began without notifying the artist concerned, Galileo Chini, who only found out at the end of that year's Biennale (1928) and threatened to sue the institution. The official exhibition poster was also designed to highlight the difference between Maraini's new conception and that of his predecessor Vittorio Pica. Comparing the 1926 poster designed by Brenno del Giudice with the 1928 poster designed by Futurist Giulio Rosso, one immediately notes a radically different treatment of the same subject: the Palazzo Ducale. While the former depicts the building in a two-dimensional image surrounded by a very ornate gilded frame, the latter seems to project the Doge's Palace into the future with bold perspective that creates a solid, geometric vision, tinged with bright colours. It gives the impression that a whole new era has been ushered in. In 1932 the architect Duilio Torres was commissioned to modernise the Palazzo dell'Esposizione facade, using four simple columns to give it a markedly rational look. Above the cornice, for the first time, the word ITALIA was added between two square blocks by sculptor Tony Lucarda, portraying St Mark's lion and the eagle of imperial Rome. VP

#### Panel

The poster of the 15th International Art Exhibition of the City of Venice, 1926. Brenno del Giudice

The poster of the 16th International Art Exhibition of the City of Venice, 1928. Officine Grafiche F. Garzia

- 1 Front of the room n.2, Central Pavilion
- 2 Catalogue of the 16th International Art Exhibition of the City of Venice, 1928
- 3 Room 18, Central Pavilion, 1928. Photo Studio Giacomelli
- 4 Letter from Antonio Maraini to Romolo Bazzoni, 7 January 1929
- 5 Room 23, Central Pavilion, 1928
- 6 Salone delle Feste and theatre arts exhibition Central Pavilion, 1928
- 7 Room 2, architectural concept by Giovanni Ponti, Central Pavilion, 1928
- 8 **Ipad**  
La Biennale di Venezia inaugurated, *Giornale Luce*, 1928  
Istituto Luce  
  
Opening of the XVII Biennale di Venezia, *Giornale Luce*, 1930  
Istituto Luce  
  
XVII Biennale di Venezia, *Giornale Luce*, 1930  
Istituto Luce  
  
Belgian pavilion, 1928  
Spanish pavilion, 1928  
USSR pavilion, 1928
- 9 Plan of the Central Pavilion, 1928
- 10 Letter from Balbino Giuliano to Benito Mussolini, 7 December 1929. Archivio Centrale dello Stato

- 11 Letter from Antonio Maraini to Romolo Bazzoni, 20 May 1930
- 12 Letter from Antonio Maraini to Benito Mussolini, 9 March 1931  
Galleria Nazionale d'Arte Moderna
- 13 Plan of the Central Pavilion, 1930
- 14 Letter from Antonio Maraini to Giuseppe Volpi Conte di Misurata,  
6 January 1931
- 15 Giovanni Boldini's retrospective individual exhibition, Central Pavilion,  
1932. Photo Studio Giacomelli
- 16 Room 19 and 20, Central Pavilion, 1932. Photo Studio Giacomelli
- 17 Room 32, Arturo Martini's individual exhibition, Central Pavilion, 1932.  
Photo Studio Giacomelli
- 18 Plan of the Central Pavilion, 1932
- 19 Letter from the Major of Venice Pietro Orsi to Giorgio de Chirico,  
7 January 1928
- 20 Letter from Antonio Maraini to Benito Mussolini, 29 June 1932  
Galleria Nazionale d'Arte Moderna
- 21 *L'esposizione di Venezia deve ritirare l'invito al pittore De Chirico*  
Gazzetta di Venezia, 18 December 1927
- 22 *Popes attack on modern art. The banned Venice exhibition.*  
*Clergy admonished to stay away*  
Daily Telegraph, 13 May 1930
- 23 *Riflessi! Biennale scandalosa*  
Riscossa, 15 May 1926
- 24 *L'esposizione di Venezia e le famiglie 'per bene'*  
Difesa del Popolo, 18 May 1930

## 2.1B The Biennale Arte, 1934 - 1938

These are the years in which Mussolini, Hitler, Goebbels, and the king of Italy all visited the Biennale, demonstrating its importance as a stage for new Italian alliances with the world. In June 1934 Hitler came to Venice to meet Mussolini for the first time. His flight landed on the Lido, where the Duce was waiting. Volpi and Maraini picked up the German chancellor and took him to the Giardini to visit the Biennale right away. He was offered a painting with a lagoon view by Fioravante Seibezzi which he refused, saying "It doesn't do justice to Venice... for me". He then paused to look at another work: *Barche* (Boats) by Memo Vagaggini, a Tuscan realist. Maraini pointed out the chancellor's interest in it to Volpi, saying – in Venetian dialect – "I'll give it to him myself". Hitler accepted with the hint of a smile. The Führer admired very few of the artworks, though he stopped to praise a "large and expressive" peasant woman by Soviet sculptor Vera Mukhina, and Édouard Manet's 1874 painting *La dame aux éventails* (Woman with Fans). He admired neither his German pavilion building nor the work inside, commenting: "I don't know much about painting. To understand painting one must make comparisons. I can't do that. I know architecture. I like architecture." In 1937, in Munich, the Führer presented an *Entartete Kunst* (Degenerate Art) exhibition, and banned all modern art. Adolf Ziegler, the neo-Renaissance painter who had organised the Degenerate Art Exhibition, was appointed president of the Reich Chamber of Fine Arts and commissar for German participation in Venice. Prior to Hitler's arrival in Italy in 1938 the German pavilion had been remodelled in neo-Greek style by architect Ernst Haiger, creating a geometric, rationalist building. Above the entrance was the symbol of Nazi Germany, an eagle on a swastika. VP

## Blow-up

Giovanni Boldini's retrospective exhibition, Central Pavilion, 1932

## Panel

*La Marcia*, by Garzia Fioresi (Alfredo Grandi), 1940  
mosaic, 150x190 cm

- 1 German pavilion, list of the participating artists, 1930
- 2 The facade of the Central Pavilion, Duilio Torres, 1932
- 3-5 Adolf Hitler visits the 19th International Art Exhibition, 1934
- 6 Benito Mussolini at the 19th International Art Exhibition, 1934.  
Photo Studio Ferruzzi
- 7 The facade of the German pavilion, 1934. Photo Studio Giacomelli
- 8 The eagle on the facade of the German pavilion (c.a. 1934-1942).  
Photo Andrea Avezzù
- 9 Piazza San Marco during the Duce's speech, 1934
- 10 Telegram from Antonio Maraini to Benito Mussolini, 18 June 1934
- 11 The facade of the German pavilion, 1938. Photo Studio Giacomelli
- 12 **Ipad**  
Venice The preparations for the "Biennale", *Giornale Luce*, 1934  
Istituto Luce  
  
Mussolini's visit to the International Art Exhibition, *Giornale Luce*, 1934  
Istituto Luce  
  
Video of the meeting between S.E. Mussolini and S.E. Hitler, Reich's  
chancellor, in Venice, June 1934  
Istituto Luce  
  
XXI International Art Exhibition, *Giornale Luce*, 1938  
Istituto Luce
- 13 Report about Adolf Hitler's visit, 1934
- 14 *Il molo - La salute*, Fioravante Seibezzi, 1934. Photo Studio Giacomelli
- 15 *Barche*, Memo Vagaggini, 1934. Photo Studio Giacomelli
- 16,17 Competition room for the frescos and the statues, Central Pavilion, 1936.  
Photo Studio Giacomelli
- 18 Central Pavilion, 1936. Photo Studio Giacomelli
- 19 The roundabout, Central Pavilion, 1938. Photo Studio Giacomelli
- 20 Catalogue - Benito Mussolini's approval, 1938
- 21 Room 3 and 4, Central Pavilion, 1936. Photo Studio Giacomelli
- 22 *Il primo decennio dell'Ente Autonomo della Biennale.*  
Special number of the *Bollettino della Biennale.*  
*L'arte nelle mostre italiane*, 1939
- 23 Competitions room, Central Pavilion, 1938. Photo Studio Giacomelli

## 2.1B Garzia Fioresi, *The March*, 1940

Garzia Fioresi was the pseudonym of Alfredo Grandi, born in Vigevano, near Pavia, on 3 June 1888. In 1902 he moved with his family to Bologna, where he studied at the Accademia di Belle Arti. His work was accepted at important Italian exhibitions such as those of the Secessione Romana, the Premio Francesco Francia in Bologna, and the Biennale and Quadriennale in Rome. He was an almost constant fixture at La Biennale di Venezia from 1912 to 1942. For the 1940 edition, fifteen of his paintings were selected, along with a cartoon for a mosaic made by the Gianese firm in Venice. The mosaic panel exhibited in a small connecting gallery of the Central Pavilion was incorrectly titled *La Marcia su Roma* (The March on Rome) in the catalogue when, in other documents, it appears simply as *La Marcia*. The image is an allegorical depiction of a Fascist parade. The Duce is on horseback in military attire, leading a group made up of soldiers, Blackshirts, women and peasants. A naked child brings up the rear as a symbol of purity. Winged figures of victory watch the scene from the sky. The roman numeral XVII indicates the Fascist calendar year that the cartoon was painted – late 1938 to early 1939. The artist also had experience with the art of mosaic itself: in 1935 he made a large panel (10 x 7 metres) for the facade of the new

Reggio Emilia railway station depicting the “proclamation of the tricolour flag”, a work which was destroyed during World War Two. VP

## 2.1C The Biennale Arte, 1940 - 1942

Despite the challenging international situation in May 1940, when the war in Europe had been raging since autumn and Italy was poised to enter it a month later, the Biennale Arte opened its doors for the 22nd edition. With a revised statute setting up a new board alongside an executive council and three subcommittees for the figurative, cinematic, dramatic and musical arts respectively, Fascist control was now total. Artists were chosen by direct invitation or through competitions for works such as frescoes and bas-reliefs on Fascist themes. In these years the exhibition featured currents that ran counter to the avant-garde, favouring harmony, tradition and balance and classic themes such as motherhood, work and family, which resulted in a showcase of mediocre art in a nineteenth-century style.

Preparations for the 1942 Biennale were even more challenging: Italy was at war and the Venetian institution had neither staff nor resources to work with. Italy’s cultural isolation led to vacuous editions where the absence of international participation was more visible than its presence. This period seems summed up by the title of an article by Gio Ponti in *Stile* magazine that railed directly against Maraini: “Italian Art Is Superior to How It Appears in the Venice Biennale”. Maraini was now under attack from many sides but not yet ready to give up, as one sees from his busy preparations for the never-to-be-held 1944 exhibition. In 1943 his power declined and he was replaced as president of the Sindacato Fascista degli Artisti; the following year he presented the Ministry of National Education with his resignation from La Biennale, bringing to an end a dazzling career of absolute dominance over artistic life during Fascism. VP

### Panel

*Bersaglieri all’assalto*, Corrado Forlin, 1942  
oil on panel, 46x60 cm

- 1, 2 Central Pavilion, 1940. Photo Studio Giacomelli
- 3 Telegram from Antonio Maraini to Romolo Bazzoni, 13 May 1939
- 4 Central Pavilion, Room 46, *Anadiomene*, Franco Asco, 1940. Photo Studio Giacomelli
- 5 Plan of the Central Pavilion, 1940
- 6 **Ipad**  
“The Emperor King goes and inaugurate the XXII. Biennale d’Arte, 1940”  
Giornale Luce, 1940. Istituto Luce
- 7 Central Pavilion, Gallery, 1940. Photo Studio Giacomelli
- 8 Letter from Antonio Maraini to Romolo Bazzoni, 17 June 1940
- 9 Central Pavilion, Room 52, Alessandro Monteleone, 1940. Photo Studio Giacomelli
- 10 Central Pavilion, Room 18, Giovanni Tizzano, 1940. Photo Studio Giacomelli
- 11 Letter from Antonio Maraini to Romolo Bazzoni, 20 June 1940
- 12 Central Pavilion, Room 32, Carlo Carrà, 1940. Photo Studio Giacomelli
- 13 Letter from Romolo Bazzoni to Antonio Maraini, 21 June 1940

- 14 *Il Conte Volpi dal Duce. Disposizioni per la Biennale*  
Gazzetta Jonica, 8 March 1942
- 15-17 Joseph Goebbels visits the 23rd International Art Exhibition with Alessandro Pavolini and Antonio Maraini, 1942. Photo Agenzia Fotografica Internazionale
- 18 *Le visite di Goebbels e Pavolini*  
Il Gazzettino, 1 September 1942
- 19 *L’arte italiana è superiore a quale appare alla Biennale di Venezia*  
Stile, July-August 1942, Gio Ponti
- 20 Plan of the Central Pavilion, 1942

## 2.1C Corrado Forlin, *Bersaglieri Attacking*, 1942

Corrado Forlin was born in Monselice on 1 May 1912. After military service in Florence, where he got his fill of Renaissance art, he returned to his hometown near Padua, studied drawing at night school, and then had a revelation: “I picked up a book by Marinetti, *L’alcova d’acciaio*. I read it even while eating, so as not to waste time. My family thought I was going mad as I laughed, squirmed, and applauded in excitement”. The relationship between the young Forlin and his idol Marinetti was probably forged in the halls of the 1936 Biennale, when Marinetti was granted use of the Soviet pavilion for his new Futurist exhibition. On 31 October that same year, the first Futurist group exhibition was held in Monselice. Forlin exhibited three paintings and a sculpture, including portraits of D’Annunzio and Marinetti titled *Il poeta di fuoco* (The Poet of Fire) and *Il poeta d’acciaio* (The Poet of Steel). Marinetti came to the provincial town on 17 December. From 1938 to 1942 Forlin was invited to take part in many editions of the Art Exhibition. In 1942 he exhibited four paintings with Fascist and military themes: *Ardentismo della Battaglia del Grano*, *Ardentismo di Bersagliere all’imbarco*, *Ardentismo di Bersagliere in sogno*, *Ardentismo di Bersagliere all’assalto*. In *Bersagliere all’assalto* (**Bersaglieri Attacking**) the perspective is that of a soldier following other troops into battle. Despite being shown in movement, the figures are well-defined, and Forlin uses complementary colours – green and red – in an interesting way to make them stand out against a blazing background. In the autumn of 1942 Corrado Forlin volunteered for combat in Russia, where he died sometime between December 1942 and the first few months of 1943. His body was never found. VP

## 2.2A Max Reinhardt, *The Merchant of Venice*, 1934

With his staging of *The Merchant of Venice*, Max Reinhardt was among the artists who inaugurated the first International Theatre Festival in 1934. Considered one of the greatest directors of all time, a pioneer in the historic shift from plot to character, Reinhardt had been forced by Nazi policies to leave Berlin in 1932, taking refuge first in Salzburg and then in the United States, where he died in 1943. Though also known for his work in film, Reinhardt devoted most of his career to the theatre, considering live performance an immortal art whose immediacy and irreproducibility can forge a “mystic union” between actor and audience. As artistic director of the Berliner Volksbühne, founded as the theatre of working-class Berlin, he was repeatedly censured for his stagings of Frank Wedekind and Arthur Schnitzler. The decision to bring Reinhardt to the Biennale showed that the Theatre Festival took an internationalist approach right from the start, in a historical context where the dramatic arts were becoming an integral, indispensable part of Italian culture.

A visionary author who drew on the world of the fantastic, Max Reinhardt overcame anti-Semitism through art, winning two Oscars in 1936 for the cinematography and editing of his film *A Midsummer Night's Dream*, as well as a Best Picture nomination.

After various trips to Venice, Max Reinhardt chose to stage *The Merchant of Venice* in Campo San Trovaso, in an Italian version translated by Paola Ojetti which ran for four performances. The almost entirely Italian cast included Memo Benassi as the wealthy Jewish moneylender Shylock, whose actions, in this directorial version, are justified by the disdain he is treated with by the Venetians. It was an entirely original reading of the work in its day. However, as in most of Reinhardt's theatre, what prevailed was the choral effect of the whole. FB

## Blow-up

*The Merchant of Venice*, by Max Reinhardt, staging works, 1934

- 1 *Un giudizio di Reinhardt su l'Arena di Verona*  
Gazzetta di Venezia, 16 September 1933, Max Reinhardt
- 2, 3, 5, 9, 13, 17, 19, 25 – 33 *The Merchant of Venice*, by Max Reinhardt, 1934.  
Photo Studio Giacomelli
- 4 *All'insegna della bella Venezia*  
L'Ambrosiano, 25 November 1933, Gino Piva
- 6, 7, 8 *The Merchant of Venice*, by Max Reinhardt, 1934  
Photo Studio Ferruzzi
- 10 *The Merchant of Venice*, by Max Reinhardt, 1934
- 11 *The Merchant of Venice*, by Max Reinhardt, 1934  
Shylock, sketch by Titina Rota
- 12 *Theater und Kunst. Die Biennale in Venedig*  
Neues Wiener, 25 May 1934
- 14 *La vivissima attesa per la rappresentazione del capolavoro shakespeariano in Campo San Trovaso*  
Gazzetta di Venezia, 17 July 1934
- 15 *Il Festival teatrale a Venezia*  
Vedetta fascista, 4 July 1934
- 16 *The Merchant of Venice*, di Max Reinhardt, 1934  
Dame di Porzia, sketch by Titina Rota
- 18 *1. Convegno Internazionale di Teatro. Stasera, prima esecuzione del Mercante di Venezia in Campo San Trovaso*  
Gazzettino di Venezia, 18 July 1934
- 20 *Festival teatralny w Wenecji - Kuplek wenecki w inscenizacji Reinhardta*  
Nasz Przegląd, 12 July 1934
- 21 *The Merchant of Venice*, by Max Reinhardt, 1934  
Antonio, sketch by Titina Rota
- 22 *The Merchant of Venice*, by Max Reinhardt, 1934  
Jessica, sketch by Titina Rota
- 23 *The Merchant of Venice*, by Max Reinhardt, 1934  
D'Aragona, sketch by Titina Rota
- 24 *The Merchant of Venice*, by Max Reinhardt, 1934  
Porzia, sketch by Titina Rota
- 34 *Der Kaufmann in Venedig*  
Berliner Tageblatt, 27 July 1934, Elisabetta Cerruti

## 2.2B “Degenerate music”

Adolf Hitler's regime, which held power in Germany from 1933 to 1945, applied the label “degenerate art” (*entartete Kunst*) to all forms of art considered contrary to Nazi ideals. In this political context, the term “degenerate music” (*entartete Musik*) was also used to condemn forms deemed corrupt or decadent. This naturally encompassed, first and foremost, the music of Jewish composers such as Felix Mendelssohn, Giacomo Meyerbeer and Gustav

Mahler, and most contemporary musicians who were experimenting with new languages (like the twelve-tone system). The reasons behind this were not only aesthetic – given the non-traditional models and styles – but racial and ideological. Many eminent composers in this period were Jewish, like Arnold Schönberg, or both Jewish and Communist, like Kurt Weill. The programmes for the International Festival of Music throughout the 1930s are interesting, however: until 1938 (the year Hitler visited Rome and he and Mussolini moved towards closer co-operation) the Teatro Goldoni calendar included the work of important exponents of “degenerate music” on a fairly regular basis, with figures such as Arnold Schönberg, Alban Berg, Ernst Krenek, Paul Hindemith, Igor Stravinsky and Béla Bartók. CF

- 1, 3 Regulations of the 3rd International Festival of Contemporary Music, 1934
- 2, 4, 5 Official programme of the 3rd International Festival of Contemporary Music, 1934
- 6 Programme of La Settimana di Venezia 8-15 September 1934
- 7 Leaflet with the subscription and individual concert prices of the 3rd International Festival of Contemporary Music, 1934
- 8, 9 Programme of the 5th International Festival of Contemporary Music, Teatro Goldoni, Venice from 6 to 12 September, 1937
- 10 *Il Festival di Venezia ed i 'musicisti di sinistra colà invitati' da Casella*  
Gazzettino, 1 July 1937
- 11 *In attesa del Festival di Venezia, Casella sotto accusa*  
Gazzetta del Mezzogiorno, 30 June 1937, Matteo Incagliati
- 12 *Musicisti di sinistra*  
L'Unione, 5 July 1937, Raffaele Cumar
- 13 Artistic report of the 5th International Festival of Contemporary Music, 1937
- 14 Score *Nobilissima visione*, Paul Hindemith, 1938
- 15 Score *Jeu de cartes*, Igor Stravinskij, 1937
- 16 Programme of the 6th International Festival of Contemporary Music of La Biennale di Venezia, 1938
- 17 Score *Musica per archi, percussioni e celesta*, Béla Bartók, 1937

## Music excerpts

*Cephalus and Procris*, Ernst Krenek, 1934

*Musica per archi, percussioni e celesta*, Béla Bartók, 1937

*Jeu de cartes*, Igor Stravinskij, 1937

*Nobilissima visione*, Paul Hindemith, 1938

## 2.2B Ernst Krenek, *Cephalus and Procris*, 1934

The 3rd International Festival of Contemporary Music was held in 1934 at a time of great tension between Mussolini's Italy and Hitler's Germany, since the latter was intent on annexing Austria (on 25 July 1934, Chancellor Engelbert Dollfuss had been assassinated in Vienna). Mussolini was pressing for a major commission to be entrusted to an Austrian composer and Alfredo Casella, a member of the festival's executive board, chose Ernst Krenek (1900-1991) – ironically, the author of *Der Diktator* (1928), inspired by Mussolini himself. *Cefalo e Procri* (*Cephalus and Procris*), based on Rinaldo Küfferle's Italian libretto, employed twelve-tone technique and was performed at Teatro Goldoni together with two other chamber pieces by Vittorio Rieti and Antonio Veretti respectively. CF

---

## 2.2B Béla Bartók, *Music for Strings, Percussion and Celesta*, 1937

One of the most important scores of the early twentieth century, *Music for Strings, Percussion and Celesta* (1936) was a composition by Béla Bartók (1881-1945) commissioned by Paul Sacher. Divided into four movements, it is an emblematic example of a sophisticated modernist style combining tonal experimentation with echoes of folk music, but also a classical sense of form. In a concert at the 1937 Festival directed by Fernando Previtali (1907-1985) at Teatro Goldoni, *Music for Strings, Percussion and Celesta* was performed for the first time in Italy together with another piece destined to make twentieth-century musical history, Sergei Prokofiev's orchestral suite based on his score for the film *Poruchik Kizhe* (Lieutenant Kijé, 1934). CF

---

## 2.2B Igor Stravinskij, *Jeu de cartes*, 1937

A ballet in three "deals", inspired by a poker game and dominated by the diabolical figure of the Joker, Stravinsky's *Jeu de cartes* debuted in New York on 27 April 1937 with choreography by George Balanchine. The orchestral version of the score, which shows sparkling creativity and a virtuoso Neoclassical approach (with an abundance of citations and reworkings from Tchaikovsky, Rossini, Johann Strauss, and Belle Époque dances) was performed for the first time at the festival on 12 September 1937 to great public acclaim; it was part of an evening entirely devoted to premiere performances conducted by their composers, including pieces by Gian Francesco Malipiero and Darius Milhaud. CF

---

## 2.2B Paul Hindemith, *Nobilissima visione*, 1938

From 1933 to 1935 the composition of the work *Mathis der Maler* (Zurich, 1938) marked the composer's break with Modernism and return to traditional values (linear melody, carefully crafted counterpoint, tonal harmony) and, at the same time, paradoxically, his marginalisation and condemnation by the Nazi regime, which obliged him to emigrate to the United States in 1940. The ballet *Nobilissima visione*, inspired by the life of St Francis, was performed in London on 21 July 1938. Paul Hindemith adapted the ballet for orchestra and the work was performed for the very first time on 13 September 1938 at the 6th International Festival of Contemporary Music at Teatro La Fenice. CF

---

## 2.2C Jia Ruskaja, *An Andersen Fairytale*, 1934

In 1934, the year Mussolini and Hitler met for the first time in Stra, near Venice, on 12 June, the ballet *Una Favola di Andersen* (An Andersen Fairytale), based on "The Little Match Girl" and with a score by Antonio Veretti, was staged at Teatro Goldoni. Antonio Maraini had championed the work, urging the staunch Fascist Adriano Lualdi, head of the Music Department, to include it in the Biennale programme. The choreography was the brainchild of Jia Ruskaja (the stage name, meaning "I'm Russian", of Evgeniya Fyodorovna Borisenko), who was born in Crimea in 1902 and died in Rome in 1970. Ruskaja, who came to Italy in the early 1920s, was a pioneer of free dance influenced by the principles of Émile Jaques-Dalcroze (1865-1950), the Swiss educator who taught "eurhythmics" (a movement-based method of music appreciation) at his school in Hellerau alongside innovative set designer Adolphe Appia. She caught the attention of the Roman

artistic and intellectual milieu as a performer in *Pantomime Futuriste* at Anton Giulio Bragaglia's Teatro degli Indipendenti. Having married Aldo Borrelli, editor-in-chief of the *Corriere della Sera*, she obtained Italian citizenship in 1935. Ruskaja choreographed outdoor ballets at the Istituto Italiano del Dramma Antico in Siracusa, as well as at the Villa Reale in Monza, the Teatro Licinium in Erba, and on the Palatine Hill, then took over as head of modern dance at La Scala's dance school in Milan, exploring the body-mind-emotion nexus and drawing inspiration from the great Italian art of the past. She carved out a place in the Fascist regime's cultural programmes, and in 1940 became director of the Regia Scuola di Danza Femminile, now the Accademia Nazionale di Danza. EGV

### Panel

Poster of the III International Festival of Contemporary Music. 8-16 September 1934/XII, G. Piombanti

- 1 Letter from Antonio Maraini to Adriano Lualdi, 25 October 1933
- 2,4 *An Andersen Fairytale*, characters and synopsis
- 3 Letter to Antonio Maraini, 4 July 1933
- 5-7, 9, 10 *An Andersen Fairytale*, Jia Ruskaja, 1934  
Photo Studio Giacomelli
- 8 *L'opera da camera al Festival di Venezia*  
Il Lavoro Fascista, 19 September 1934, Mario Labroca
- 11 *Terzo Festival Internazionale di Musica*  
Il Gazzettino di Venezia, 16 September 1934
- 12, 14 Official programme of the 3rd International Festival of Contemporary Music, 1934
- 13 Exhibition catalogue of Adolphe Appia's artwork, Edmund Stadler, XXII International Theatre Festival, 1963

## 2.3 Futurism at the Biennale, 1926 - 1942

In the early 1920s Italian participation at the Biennale Arte was shaped by Margherita Sarfatti and the influence of her Novecento Italiano movement. When this Venetian writer's hold over Mussolini faded, Filippo Tommaso Marinetti asserted the claim of Futurism – especially its heroic *Aeropittura* incarnation – to become the official art of the regime. In 1923 Futurist works could already be seen in Venice: a painting and set design exhibition was held at the Lido by Enrico Prampolini. At the inauguration of the 14th International Art Exhibition in 1924, in the presence of the king and of Minister Gentile, Marinetti and his colleagues staged a noisy protest about the lack of Futurist work at the exhibition, and Marinetti was jailed for a few hours. The absence of Futurists at the Biennale Arte was however due in part to Marinetti's unbending unwillingness to let the movement's painters present work to the jury individually. He alone was to select artists and the movement was to remain united. In 1924 Gerardo Dottori broke this rule, exhibiting a painting at that year's Biennale. In late July 1925 Marinetti wrote to La Biennale secretary, staking Futurism's claim to the next edition. He wanted five rooms and, above all, a group exhibition of work he alone would select. To this end he wrote to his old friend Margherita Sarfatti, who managed to secure him two rooms in the Central Pavilion and the opportunity for artists to be directly selected by him rather than the jury. In the end, when the Soviet Union unexpectedly withdrew from the 15th International Art Exhibition in 1926, the Soviet pavilion was handed over to Marinetti: he exhibited sixty

works that spanned painting, sculpture, and the applied arts, with Depero and Prampolini as the best represented artists. From 1928 to 1942 the Futurists were a constant fixture at the Biennale. One can see Marinetti's influence grow from 1928, when he was allotted only the smallest, most out-of-the-way gallery in the Palazzo dell'Esposizione (room 39), to later editions where the movement was granted increasing space and visibility, showing this poet's noteworthy diplomatic skills. In 1936 he was once again given the Soviet pavilion and, in 1942, Belgium's. VP

### Blow-up

Italian Futurists, Central Pavilion, 1930

### Panel

*Bombardamento aereo*, Giovanni Chetoffi, 1942  
oil on canvas, 91x100 cm

- 1 *Il gruppo futurista italiano alla XV Biennale di Venezia*  
Gazzetta di Venezia, 13 March 1926
- 2 Postcard by Giacomo Balla, 7 March 1931
- 3, 4 Mostra del Futurismo italiano, Fortunato Depero, 1926
- 5 *I pittori futuristi alla XV Biennale d'arte di Venezia*  
L'Antenna, 16 May 1926, Enrico Prampolini
- 6, 8 Staging of Filippo Tommaso Marinetti's Italian futurist theatre, 1928.  
Photo Studio Giacomelli
- 7 Central Pavilion, Italian Futurists, 1930
- 9 Letter from Enrico Prampolini to Antonio Maraini, 28 March 1930
- 10 *Una vivace intervista con Filippo Tommaso Marinetti*  
Il Giornale del Veneto, 27 April 1926
- 11 *La nuova pittura futurista*, report by Filippo Tommaso Marinetti, 1930
- 12 Italian Futurism Pavilion, 1936. Photo Studio Giacomelli
- 13 Central Pavilion, Italian Futurist Aeropainters Exhibition, 1934.  
Photo Studio Giacomelli
- 14 King Vittorio Emanuele III visits the 23rd International Art Exhibition,  
Enrico Prampolini explains his artwork, 1942
- 15 King Vittorio Emanuele III visits the 23. International Art Exhibition,  
Filippo Tommaso Marinetti talks to the King, 1942.  
Photo Studio Giacomelli
- 16, 17 King Vittorio Emanuele III visits the 23rd International Art Exhibition,  
1942

## 2.3 Ivan Ketoff, *Aerial Bombardment*, 1942

**Ivan Ketoff (or Ketov) was born in Rome to Russian parents in 1916. He attended set design courses and soon came across Futurism, thanks to Anton Giulio Bragaglia and Enrico Prampolini. In 1933 he showed his work in the First National Futurist Exhibition, held in Rome at the Palazzo del Sindacato Ingegneri in Piazza Adriana. In 1938 he trained as a pilot and began painting flight-themed work, also taking part in exhibitions with the Aeropittura group. He Italianised his name to Giovanni Chetofi (or Chetoffi) and was in the 1938 and 1940 Biennales with two paintings at each: *Volo rasente* and *Volando sulla foce* in 1938, and *Cromatismo aerei* and *Dimenticando la terra* in 1940. At the 1942 Biennale Arte, eight of his paintings were selected for the Italian Royal Air Force pavilion ("*Caccia*" tutto fare, *Combattimento aereo*, *Alessandria*, *Picchiatelli*, *Mitragliamento di Iraklion*, *Attaccano i paracadutisti*) and two for the Futurism pavilion: *Aerosintesi dell'Egeo* and *Bombardamento aereo*. This latter shows what the aviator would see during a bombing mission: the countryside is punctuated by the white lines of roads and the yellow and green geometric shapes of fields. The military objective is at the centre of the composition, a group of buildings hit by bombs which blow up to form white clouds in the sky. VP**

## 2.4A The national pavilions at the Giardini, 1940-1942

In the two editions of the Biennale Arte held during the war, the layout of the Giardini di Castello area was revolutionised. In 1940 France withdrew at the last minute and the decision was taken to occupy that pavilion with paintings and sculptures that had been entered in the portraiture competition. Together with France, three weeks before the opening, Great Britain and Denmark withdrew. Austria, Poland and the Soviet Union had never signed up and all these pavilions thus remained closed. In 1942 the political situation demanded drastic management choices to keep pavilions from sitting shuttered as they had the previous year. The only foreign countries invited as "neither enemy nations nor controlled by the latter" were Germany, Bulgaria, Croatia, Denmark, Romania, Slovakia, Spain, Sweden, Switzerland and Hungary. Japan and Finland were invited to the exhibition but technical reasons prevented them from sending work to Venice. The 23rd International Biennale Exhibition in 1942 was the first to be organised in the middle of a world war. During the Great War it had been suspended, but this time Mussolini wanted cultural activities to continue. The enemy nation pavilions – except Belgium's, which was handed over to the Futurists – showcased entries in the competitions on the theme of war "on land and at sea, in the skies, or life in Fascist times". Given the scarcity of work good enough for the exhibition, the jury decided to present work "showing sufficient dignity" in the Greek pavilion. The British, French and United States pavilions housed the most important works selected by Italy's Ministry of War, Air Force and Navy. VP

### Blow-up

Map of the Giardini, 1942

- 1 Letter from the Embassy of the French Republic to Giuseppe Volpi Conte di Misurata, 28 December 1939
- 2 Letter from the USSR Embassy to Giuseppe Volpi Conte di Misurata, 16 April 1940
- 3 Letter from the Ministry of Foreign Affairs to La Biennale, 4 May 1940
- 4 Map of the Giardini, 1940
- 5 Prefectural decree relating to the seizure of Greek assets, 24 December 1940
- 6 Greek pavilion, 1940. Photo Studio Ferruzzi
- 7 Telegram from the British Council to Antonio Maraini, 26 April 1940
- 8 Letter from the Ministry of Foreign Affairs to La Biennale, 17 November 1941
- 9 *Pronti!* Arno Breker, German pavilion, 1940. Photo Studio Ferruzzi
- 10 *Javelin thrower*, Hans Wimmer, German pavilion, 1940.  
Photo Studio Ferruzzi
- 11 German pavilion, 1940. Photo Studio Ferruzzi
- 12 Letter from Antonio Maraini to Romolo Bazzoni, 1 November 1941
- 13 Letter from Alessandro Pavolini to Antonio Maraini, 24 August 1942
- 14 Swiss pavilion, 1940. Photo Studio Ferruzzi
- 15 Bohemian and Moravian pavilion, 1940. Photo Studio Ferruzzi
- 16 Yugoslavian pavilion, 1940. Photo Studio Ferruzzi
- 17 Spanish pavilion, 1940. Photo Studio Ferruzzi
- 18 External view of the Royal Navy pavilion, 1942.  
Photo Studio Giacomelli
- 19 The Royal Navy pavilion, 1942. Photo Studio Giacomelli
- 20 The Royal Army pavilion, 1942. Photo Studio Giacomelli

- 21 External view of the Royal Army pavilion, 1942. Photo Studio Giacomelli
- 22 The Royal Navy pavilion, 1942. Photo Studio Giacomelli
- 23 The Royal Air Force pavilion, 1942. Photo Studio Giacomelli
- 24 Letter from Antonio Maraini to the Embassy of Germany, 30 September 1941
- 25 *I padiglioni delle Forze armate*  
Roma = Napoli, 11 August 1942, Alfredo Schettini

## 2.4B The national pavilions at the Giardini, 1943-1945

With the armistice and German invasion on 8 September 1943, Cinecittà closed down. As the Republic of Salò was set up, Istituto Luce, ENIC, CINES, Scalera Film and the Ministry of Popular Culture all moved to Venice. Ferdinando Mezzasoma, the new minister, agreed with the Germans that the core of the Italian film industry should be transferred from Rome to Venice, both because it was unlikely to be bombed, and because they thought they could requisition the nearly completed Scalera studios on the island of Giudecca Island. After transferring a portion of the technical material, the actors had to be convinced to move North, as did the skilled labour and the administrative staff. The issue of sound stages remained a significant problem as well. After ruling out the use of the Scalera buildings on the Giudecca because of determined opposition from the production house, which immediately set to work on Giorgio Ferroni's *Senza famiglia*, Cinecittà president Luigi Freddi fell back on the pavilions at the Giardini della Biennale, which lent themselves well to production demands. La Biennale initially resisted pressure from the two ministers but then gave in, given the impossibility of staging the International Art Exhibition the following year. On 11 January 1944 Antonio Maraini thus wrote to Freddi: "Destiny has decreed an even closer bond between the Biennale and cinema. Now even its halls and pavilions will host this art. I'm pleased... Instead of Cinecittà, the word on every screen will be Cinebiennale!"

On 21 February 1944 the first scenes of Piero Ballerini's *Fatto di cronaca* were shot, followed by a few other films: in 1944 Flavio Calzavara's *Peccatori*, Mario Baffico's *Ogni giorno è Domenica* and Fernando Cerchio's *La buona fortuna*, and in 1945 Mario Baffico's *Trent'anni di servizio*. The liberation of Italy brought the Cinebiennale venture to an end. GG

- 1. Letter from the Società Anonima Imprese Cinematografiche Spettacoli Affini ICSA to La Biennale, 12 April 1943
- 2. Convention between the Ente Autonomo La Biennale di Venezia and the Società Cines for the concession of properties located in Venice in the enclosure of the International Art Exhibition and on the island of Saint Elena, 25 August 1944
- 3. Map of the state of occupation of the Pavilions at the Giardini della Biennale, 1944
- 4. Letter from the Minister of Popular Culture to La Biennale, 3 February 1944
- 5. *L'eccellenza Mezzasoma inaugura i nuovi stabilimenti cinematografici ai Giardini* Gazzettino di Venezia, 22 February 1944
- 6. Letter from Romolo Bazzoni to Enrico Abba (Albergo Marino), 17 June 1944
- 7. **Ipad**  
Videos about the occupation of the Biennale pavilions for 'Cinevillaggio' 1944-1945. Istituto Luce  
Istituto Luce newsreels 1944. Istituto Luce  
*Ogni giorno è domenica* by Mario Baffico, 1944

- 8. Convention between the Ente Autonomo La Biennale di Venezia and the Istituto Nazionale Luce for the concession of properties located in Venice in the enclosure of the International Art Exhibition and on the island of Saint Elena, 6 April 1945
- 9. Prefectural decree relating to the seizure of the German pavilion, 6 December 1945
- 10. Letter from the Town of Venice to La Biennale, 21 December 1945
- 11. Convention between the Ente Autonomo La Biennale di Venezia and the Società Mira-Lanza for the concession of properties located in Venice in the enclosure of the International Art Exhibition and on the island of Saint Elena, 6 March 1945
- 12. Complaint from the Town of Venice to the Reich's Government, 25 August 1945
- 13. Letter from Romolo Bazzoni to the Prefecture of Venice, 16 January 1946
- 14. Letter from Giovanni Ponti to the Presidency of the Council of Ministers, 23 April 1946
- 14. Current position and situation of the Ente Autonomo La Biennale di Venezia, memo, June 1945
- 15. Message from the Cassa di Risparmio di Venezia to the Prefecture of Venice and to La Biennale, 12 April 1946
- 16. Letter from the Associazione Pittori Scultori Veneziani to the President of the Council of Ministers, 21 June 1946
- 17. Letter from Elio Zorzi to the Presidency of the Council of Ministers, 2 August 1946
- 18. Act of military requisition of the Palazzo del Cinema by United States Army, 1 May 1947

## 2.5 Cinema goes to war, 1940-1942

In 1940 the Palazzo del Cinema on the Lido had been requisitioned by the armed forces, so the 8th Venice International Film Festival was held in the historic centre, at the San Marco and Rossini cinemas. As with the visual arts exhibitions, only Axis allies or neutral countries were allowed to take part in what was branded the "Italo-Germanic Cinema Week": Bohemia, Germany, Italy, Romania, Sweden, Switzerland and Hungary (in 1941 and in 1942 Argentina, Spain, Denmark, Finland and Norway added their names to the list). "Venice seemed truly unreal," wrote Antonioni. The tone was more subdued than earlier editions: Hotel Danieli and Ca' Giustinian were a rendezvous for Culture Minister Alessandro Pavolini, Cinecittà President Luigi Freddi, the couple Luisa Ferida and Osvaldo Valenti, Vittorio De Sica, the Third Reich diva Brigitte Horney, and the Czech star Lída Baarová. Special screenings were offered to the armed forces and Fascist leaders paraded across the stage. Nor did the war prevent Goebbels from taking part in the event and imposing official speeches about the cinema of the New Europe soon to be ushered in.

Veit Harlan's infamous *Jud Süß* (1940), Augusto Genina's pro-Franco propaganda film *L'assedio dell'Alcazar* (1940) and Goffredo Alessandrini's *Noi vivi* (1942) were all screened. Mino Doletti, editor of *Film quotidiano*, wrote that while the "war is fought in the trenches," in Venice the "war is fought over prizes." But it was only nominally a "war", since Count Volpi and the delegates from participating nations always divided the Coppa Mussolini awards equally between one Italian and one German movie (Augusto Genina's *L'assedio dell'Alcazar* and Gustav Ucicky's *Der Postmeister* in 1940, Alessandro Blasetti's *La corona di Ferro* and Hans Steinhoff's *Ohm Krieger* in 1941, Augusto Genina's *Bengasi* and Veit Harlan's *Der grosse Koenig* in 1942). When Fascism fell in the summer of 1943 the festival was suspended, but as early as October, the spectral Republic of Salò was trying to rekindle



## Blow-up

Screening for the Armed Forces, 1942. Photo Afi

## Monitor

Newsreels 1940-1942. Istituto Luce

- 1 Joseph Goebbels arriving in Venice, 1942. Photo Afi
- 2 Cinema Rossini, Venice, 1942. Photo Studio Giacomelli
- 3 Posters of the movies presented at the X Venice International Film Festival, 1942. Photo Studio Giacomelli
- 4 Joseph Goebbels arriving in Venice, 1942. Photo Afi
- 5, 6, 8 Joseph Goebbels arriving in Venice, 1942. Istituto Luce, Photo Library
- 7 Joseph Goebbels arriving in Venice, 1942. Photo Afi
- 9 Screening for the Armed Forces, 1942. Photo Afi
- 10 The audience in the movie theatre at the X Venice International Film Festival, 1942. Photo Afi
- 11, 13 The audience in the movie theatre at the X Venice International Film Festival, 1942. Photo Studio Ferruzzi
- 12 The audience in the movie theatre at the X Venice International Film Festival, 1942. Photo Cameraphoto
- 14 Gino Cervi and Giuseppe Volpi di Misurata, 1942. Photo Cameraphoto
- 15, 16 The Minister of Popular Culture Alessandro Pavolini arriving in Venice, 1942. Photo Studio Giacomelli
- 17 Magazine Film Quotidiano, n. 2 (Sunday 31st August) 1941. Private Collection

# ROOM 2B

## THE COLD WAR AND THE NEW WORLD ORDER, 1947 - 1964

La Biennale went back to work in 1946 under the leadership of its new commissar Giovanni Ponti, first with the reopening of the Venice Film Festival, directed by Elio Zorzi, and then with the International Festival of Music. It would be a few more years before the visual arts section reopened, given the need to finalise work on the Giardini pavilions. The International Art Exhibition reopened in 1948 with an edition focusing on reconstruction; this was Europe's first major international exhibition after World War Two and came seven years before Documenta, the famous German contemporary art exhibition in Kassel. Secretary General Rodolfo Pallucchini grasped the need to bring the Biennale up-to-date with a series of earlier artistic languages and experiments which had been forgotten or censored under Fascism. 1948 was the year of the first solo exhibition by then 67-year-old Pablo Picasso, an artist who had never previously exhibited at the Biennale. For this same edition Peggy Guggenheim came to Venice and brought her collection to the Greek pavilion, showing not only exceptional modern art from Europe but also new American abstract artists. With Picasso's works, the Guggenheim exhibition, the Fronte Nuovo delle Arti's contribution at the Padiglione Italia, and many other exhibiting artists, this edition of the Biennale highlighted the dialogue and debate between abstraction and figuration. It was a polarisation that could also be seen as a counterpart to the ideological differences between the two Cold War blocs that pervaded many of the political and aesthetic debates of those years, when the Soviet-influenced language of Socialist Realism faced off against the Western liberalist Esperanto of abstract art.

A similar tension could be sensed at the film festival. This was the era when Hollywood came to Venice and Luchino Visconti presented great Neorealist masterpieces such as *La Terra Trema*, *Senso* and *Rocco e i suoi fratelli*, which because of the director's Communist Party affiliation won no official recognition. Dance, too – a discipline which had not yet become its own official department of La Biennale,

but was included in the music and theatre festivals – brought its first American experiments to Venice, with George Balanchine's New York City Ballet. In 1951, Biennale Teatro invited Bertolt Brecht to stage *Mutter Courage und ihre Kinder*, but it was ultimately cancelled as a result of the Italian government's refusal to grant entry visas to Brecht and his Berliner Ensemble, who were from East Germany. The music festival, on the other hand, welcomed Soviet musicians such as Sergei Prokofiev and Dmitri Shostakovich whose musical compositions were a world away from Socialist Realism canons and thus were frequently blocked in the Soviet Union, but presented in Venice at several prestigious concerts. CA

# ROOM 2B

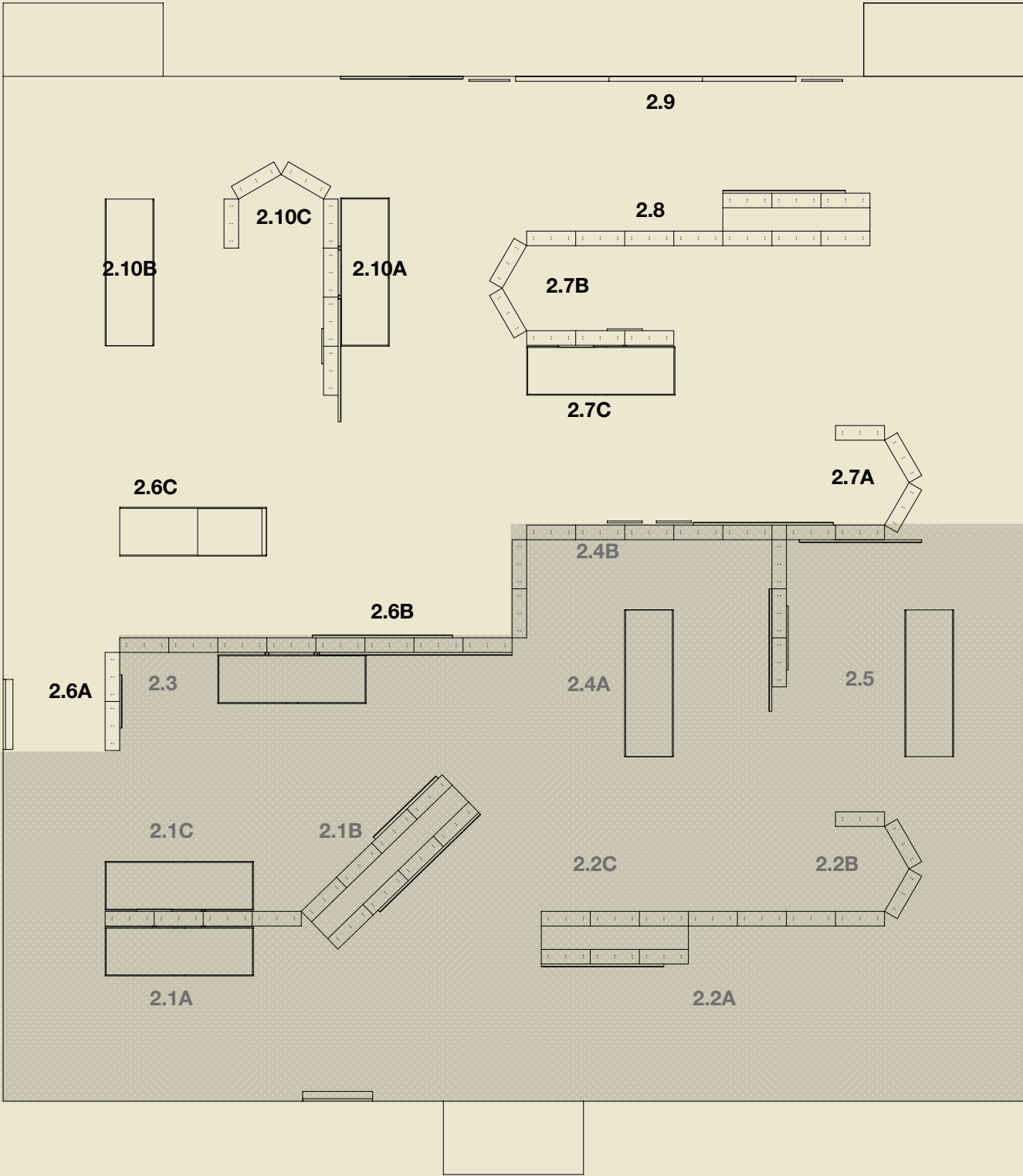

## 2.6A The Biennale of the reconstruction

### Panel

Poster of the 24th International Art Exhibition, 1948  
Giacinto Mondaini

- 1 Telegram from Stefan Plonski to La Biennale, 15 March 1948
- 2 Letter from Rodolfo Pallucchini to Aberhard Hanfstaengl, 10 December 1947
- 3 Catalogue, Introduction by Rodolfo Pallucchini, 1948
- 4 Letter from the Foreign Affairs Minister to Giovanni Ponti, 2 February 1948
- 5 Letter from the Foreign Affairs Minister to Giovanni Ponti, 16 April 1948
- 6 Letter from Giovanni Ponti to James Johnson Sweeney, October 1947
- 7 Map of the Giardini, 1948
- 8 Appointment letter to Ettore Gian Ferrari, 19 April 1950
- 9 Letter from Erwin S. Barrie to Rodolfo Pallucchini, 18 November 1947
- 10 Letter from Ettore Gian Ferrari, 26 April 1950

## 2.6B The exhibitions at the Biennale Arte 1948

In 1948 the 24th International Art Exhibition included major historical exhibitions such as those on the Impressionists, Metaphysical Painting and Degenerate Art; there were retrospectives and solo exhibitions of work by Gino Rossi, Scipione, Arturo Martini, Paul Klee, Marc Chagall, Henry Moore and Pablo Picasso (at the Biennale for the first time) and extraordinary surveys of the Fronte Nuovo delle Arti and the Peggy Guggenheim collection. The two rooms hosting the Fronte Nuovo delle Arti were especially interesting because they brought together young artists from a range of Italian cities, above all Venice, Milan and Rome. Key players in this movement were Renato Birolli, Antonio Corpora, Nino Franchina, Renato Guttuso, Leoncillo Leonardi, Ennio Morlotti, Armando Pizzinato, Giuseppe Santomaso, Giulio Turcato, Emilio Vedova and Alberto Viani. It developed out of the Nuova Secessione Artistica Italiana, founded the previous year in Milan as an outgrowth of the Bottega di Corrente cultural space. The aim of the Fronte members was to make painting a political act, using a straightforward, direct artistic language. Their rejection of the Novecento movement was total, favouring instead a dialogue with European painting: the model for this politically committed art was Picasso's *Guernica*. The movement's founder and theorist was art critic Giuseppe Marchiori. Shortly after the first exhibition two opposing factions formed, one made up of artists influenced by Neorealism and the other with more avant-garde, abstract or Informel leanings. It was the artists of this second faction who defied the Communist Party's prejudice against abstract art and brought the Fronte to an end.

### De Chirico at the Biennale

In 1948 the jury decided to award Giorgio Morandi the painting prize. The Bologna-born artist had been featured, together with de Chirico and Carlo Carrà, in the *Tre pittori italiani dal 1910 al 1920* exhibition. In the press, Giorgio de Chirico accused the institution

of having sent him no official invitation or requests, and of having chosen, without his input, a series of paintings from private collections that included a "tremendous fake". De Chirico sued La Biennale and did not take part in the editions of subsequent years, instead bringing solo exhibitions to Venice from 1950 to 1954 as a sort of anti-Biennale in the Giardinetti Reali Kaffeehaus. One of de Chirico's most memorable works at the 1948 exhibition was *Le Muse inquietanti* (The Disquieting Muses) from the Feroldi Collection in Milan. Painted in Ferrara in 1916, during World War One, this painting is a manifesto of Metaphysical Art, featuring inanimate objects and dummy-headed statues arranged on a stage-like wooden floor in a town square. In the background is Ferrara's Castello Estense alongside the twin smokestacks of a factory, silhouetted against the evening sky. *Le Muse inquietanti* is the perfect example of the immortal artwork which, as de Chirico himself noted, "must transcend human limits without worrying about either common sense or logic". VP

- 1, 2 Visual Arts Commission, 1948
- 3 Pablo Picasso with Rodolfo Pallucchini and Elio Zorzi at Antibes, 1948
- 4 Impressionists Exhibition, 1948. Photo Studio Giacomelli
- 5 **Ipad**  
Video International Art Exhibition: in Venice: Impressionists exhibition, La Settimana Incom, 1948  
Istituto Luce  
  
Video International Art Exhibition in Venice: the Italian pavilion, La Settimana Incom, 1948  
Istituto Luce  
  
Video International Art Exhibition in Venice: "Personal exhibitions at La Biennale di Venezia": Braque and Kokoschka, La Settimana Incom, 1948  
Istituto Luce
- 6 Pablo Picasso's portrait. Photo Interfoto
- 7, 8 Pablo Picasso with Rodolfo Pallucchini and Elio Zorzi, 1948. Photo Interfoto
- 9 Central Pavilion, Pablo Picasso's personal exhibition, 1948. Photo Studio Giacomelli
- 10 Umbro Apollonio and Rodolfo Pallucchini before Arturo Martini's artwork, *Aviatore*, 1948
- 11 Rodolfo Pallucchini, Umbro Apollonio and Giulio Baradel, at Pablo Picasso's personal exhibition, Central Pavilion, 1948
- 12 Palma Bucarelli at Pablo Picasso's personal exhibition, Central Pavilion, 1948. Photo Interfoto
- 13 Central Pavilion, 1948. Photo Studio Giacomelli
- 14 *Segnalazioni*  
Rinascita, year V - n. 11, November 1948, by Rodrigo di Castiglia (Palmiro Togliatti)
- 15 *Per una nostra segnalazione*  
Rinascita, year V - n. 12, December 1948, by Pietro Consagra, Renato Guttuso, Aldo Natili, Paolo Ricci, Mario Mafai, Giulio Turcato, Nino Franchina, Leoncillo Leonardi, Mario Penelope, Saro Mirabella, G. Vittorio Parisi, Giuseppe Mazzullo, Concetto Maugeri, Paolo Bracaglia Morante
- 16 Visitors at the 24th Biennale di Venezia, 1948. Photo Interfoto
- 17 Central Pavilion, Il Fronte Nuovo delle Arti, 1948. Photo Studio Giacomelli
- 18 Paul Klee, 1948. Photo Studio Ferruzzi
- 19 *Hitler non voleva questa pittura.*  
Milano Sera, 17 March 1949
- 20 *The Disquieting Muses*, Giorgio de Chirico, 1948. Photo Studio Giacomelli
- 21 Giorgio de Chirico and Arturo Martini's room, Central Pavilion, 1948. Photo Studio Giacomelli
- 22 *Partito modernista e Biennale di Venezia*  
Il Giornale, 3 November 1949, by Giorgio de Chirico

- 23 *Scandalo alla Biennale*  
Il Giornale della Sera, 7 October 1949, by Giorgio de Chirico
- 24 *Roberto Longhi reagisce alle frecciate di De Chirico*  
Il Giornale dell'Emilia, 16 October 1949
- 25 *Ridicole, false e costose (de Chirico ci scrive)*  
Il nazionale, 19 February 1950, by Giorgio de Chirico
- 26 *Artist sues Biennale for showing his canvasses without permission*  
The Rome Daily American, 7 July 1949
- 27 *De Chirico vince la causa contro la Biennale di Venezia*  
Corriere della Sera, 2 August 1951
- 28 Court of Venice's judgement in the Giorgio de Chirico's case against La Biennale, 5 July 1951

## 2.6C The Guggenheim Collection at the Greek pavilion, 1948

Peggy Guggenheim played a pivotal role in the history of twentieth-century art. She often said it was her duty to protect the art of her day, and devoted most of her life to this mission and to creating her museum. Arriving in Venice for the first time after World War Two, in 1946, she met the painters Emilio Vedova and Giuseppe Santomaso at Ristorante All'Angelo. When Rodolfo Pallucchini learned of her plan to transfer her Art of This Century gallery from New York to Venice, he immediately suggested exhibiting the work at the Greek pavilion, which would be empty that year owing to the civil war underway. As Peggy recalled in her biography, "my pavilion was [...] done over by Scarpa, who was the most modern architect in Venice". The Biennale opening was very formal and Peggy had nothing suitable to wear, so she asked a friend to loan her a pair of stockings and a belt, and instead of the customary hat she wore a pair of huge daisy-shaped earrings made of Murano glass. Thus decked out, she greeted the President of the Italian Republic, Luigi Einaudi. "My exhibition had enormous publicity [...] but what I enjoyed most was seeing the name of Guggenheim appearing on the maps in the Public Gardens next to the names of Great Britain, France, Holland, Austria, Switzerland, Poland [...] I felt as though I were a new European country." For Italy the Guggenheim Collection was a unique opportunity to see the best of avant-garde European art, especially abstract and Surrealist work, but also the art of young Americans like Jackson Pollock and Clyfford Still. VP

### Blow-up

Peggy Guggenheim during the preparation of the Greek pavilion with *Mobile*, 1941 by Alexander Calder, XXIV Biennale di Venezia, 1948

Model of the installation of the Peggy Guggenheim collection in the Greek pavilion, 1948  
Model by Ivan Simonato, 2018, 110x80x38 cm  
Solomon R. Guggenheim Foundation, Venice

- 1 Peggy Guggenheim during the installation of the Greek pavilion with *Interno olandese II*, 1928 and *Donna seduta II*, 1939 by Joan Miró, XXIV Biennale di Venezia, 1948  
Solomon R. Guggenheim Foundation, Venice, photo Archivio Cameraphoto Epoche. Gift, Cassa di Risparmio di Venezia, 2005
- 2 Letter from Tupalde Forestis to Peggy Guggenheim, 11 June 1948  
Peggy Guggenheim Scrapbook, 1948-49, Solomon R. Guggenheim Foundation, New York
- 3 Invitation to the opening of La XXIV Biennale di Venezia, 1948  
Peggy Guggenheim Scrapbook, 1948-49, Solomon R. Guggenheim Foundation, New York
- 4-7 The Peggy Guggenheim collection, 1948. Photo Studio Ferruzzi

- 8 *Una collezionista ricorda*, Peggy Guggenheim, 1956
- 9 Pegeen Vail, XXIV Biennale di Venezia, 1948  
Peggy Guggenheim Scrapbook, 1948-49, Solomon R. Guggenheim Foundation, New York
- 10 Peggy Guggenheim welcomes the President Luigi Einaudi at the opening of the exhibition at the Greek pavilion, XXIV Biennale di Venezia, 1948  
Solomon R. Guggenheim Foundation, Venice, photo Archivio Cameraphoto Epoche. Gift, Cassa di Risparmio di Venezia, 2005
- 11 The President Luigi Einaudi, Peggy Guggenheim and Rodolfo Pallucchini (from the left), XXIV Biennale di Venezia, 1948  
Peggy Guggenheim Scrapbook, 1948-49, Solomon R. Guggenheim Foundation, New York
- 12 Peggy Guggenheim with Luigi Einaudi and Rodolfo Pallucchini, for the opening of the Peggy Guggenheim collection, 1948
- 13 Peggy Guggenheim with Arturo Tosi, 1948  
Photo Interfoto
- 14 *Venice Biennale. Modern art and artists are seen in an ancient city*  
Lee Miller's interview to Peggy Guggenheim, Vogue  
Solomon R. Guggenheim Foundation, Venice
- 15 Greek pavilion, XXIV Biennale di Venezia, 1948  
Peggy Guggenheim Scrapbook, 1948-49, Solomon R. Guggenheim Foundation, New York Photo Schulthess
- 16 Marc Chagall and Rodolfo Pallucchini, Greek pavilion, 1948.  
Photo Interfoto
- 17 Lionello Venturi, Carlo Scarpa e Peggy Guggenheim at the Greek pavilion, XXIV Biennale di Venezia, 1948  
Peggy Guggenheim Scrapbook, 1948-49, Solomon R. Guggenheim Foundation, New York

## 2.7A/2.7B Russian musicians at the Biennale Musica

In the Soviet Union, state control over the arts was especially rigid not only in the period of Stalin (which ended in 1953 with his death) but also in the decades that followed. The Socialist Realism doctrine, imposed on the country in 1934 by Andrei Zhdanov, the regime's cultural policy arbiter, was designed to combat Western influences on Soviet artists and had a significant impact on music as well. Tendencies which were seen, often on specious grounds, as connected to decadence, pessimism (social, political, or existential), psychological introspection and, naturally, modernist experimentation were all subject to censorship. Music not held to be in keeping with the canons of Socialist Realism was condemned as formalistic and intellectualistic, in a systematic campaign of control and repression which harshly affected Sergei Prokofiev (1891-1953) and Dmitri Shostakovich (1906-1975), together with younger composers such as Sofia Gubaidulina (1931-), whose music was dubbed "irresponsible". The history of the Biennale Musica is dotted with performances of work by Soviet composers who were censored at home. CF

### 2.7A Dmitri Shostakovich, *Lady Macbeth of Mtsensk*, 1947

Shostakovich's opera *Ledi Makbet Mtsenskogo uyezda* (*Lady Macbeth of Mtsensk*), though triumphantly staged in Leningrad in 1934, was shelved and banned in the Soviet Union in 1936 as a result of Zhdanov's Stalinist repression. Applauded in 1934 as a stellar result of the Communist Party's cultural policies, two years later it was condemned in Pravda as formalist and immoral and thus "unfit for the Soviet people" with its "success with the bourgeois audience abroad" seen as especially damning. Though reworked and purged by its author to please the censors, the piece was performed again in the Soviet Union in a new version entitled *Katerina Izmailova* only on 8 January 1963 in Moscow, during

the Khrushchev period. It was first performed in Italy for the 10th International Festival of Contemporary Music at Teatro La Fenice in 1947, with sets designed by Aurel Milloss and scenery and costumes by Renato Guttuso. The extraordinary acclaim that it received led the work to be presented across Europe and the United States, in both fully staged and concert form. CF

## Blow-up

*Lady Macbeth of Minsk*, Dmitri Shostakovich, 1947.  
Photo Studio Giacomelli

- 1 Programme of the 10th International Festival of Contemporary Music and Autunno Musicale Veneziano
- 2 Cover of the 10th International Festival of Contemporary Music catalogue. Autunno Musicale Veneziano Teatro La Fenice 1947, Giuseppe Santomaso
- 3 *Musica pornografica*  
Domus, n. 222, 1947, Riccardo Malipiero
- 4 *'Lady Macbeth' di Shostakovic apre l'Autunno Musicale di Venezia*  
Gazzetta Veneta, n. 294, 12 September 1947, Gino Damerini
- 5-7 *Lady Macbeth of Minsk*, Dmitri Shostakovich, 1947.  
Photo Studio Giacomelli

## Panel

First act, first and third painting and second act, second painting for *Lady Macbeth of Minsk*, Renato Guttuso, 1947  
Tempera and China ink on paper, 38.5 x 60 cm

Second act scenery - first painting for *Lady Macbeth of Minsk*, Renato Guttuso, 1947  
Tempera on paper, 39.4 x 58.4 cm

Music excerpt *Lady Macbeth of Minsk*, Dmitri Shostakovich, 1934

## 2.7B Sergei Prokofiev, *The Fiery Angel*, 1955

Sergei Prokofiev never got to see his own opera *Ognenny angel* (*The Fiery Angel*), based on a novel of the same name by Valery Bryusov and composed between 1919 and 1927. This work hinges on the ambiguities of a passionate religious obsession, where asceticism is mingled with ecstasy and madness; it also explores the tension between faith in reason, on one hand, and the power of the unconscious and superstition, on the other. Though Prokofiev had been targeted by Soviet censors since 1936, and his subject was scandalous in moral and religious terms, what kept the work from being performed during the composer's lifetime was not censorship so much as the inherent difficulties of the score and staging (initial production talks with theatres in Chicago, Berlin and New York ended up coming to nothing). Its premiere at Teatro La Fenice in 1955 during the 18th International Festival of Contemporary Music, in an Italian version by Mario Nordio titled *L'angelo di fiamma* with sets by Giorgio Strehler, was therefore an international event, coming two years after Prokofiev's death. CF

- 1 Letter from Nino Sanzogno to Alessandro Piovesan, 7 May 1955
- 2 *Libretto of The Fiery Angel: an opera in 5 acts and 7 paintings* by Sergei Prokofiev, literal version by Mario Nordio
- 3 Letter from Nino Sanzogno to Alessandro Piovesan, 8 August 1955
- 4 Letter from Giorgio Strehler to Alessandro Piovesan (s.d.)
- 4 Letter from Giorgio Strehler to Alessandro Piovesan, 11 August 1955
- 5 *The Fiery Angel*, Sergei Prokofiev, 1955.  
Photo Studio Giacomelli
- 6-9, 12 *The Fiery Angel*, Sergei Prokofiev, 1955
- 10 *C'è un inutile Mefistofele nell'Angelo di Prokofiev*  
Corriere d'informazione, 15 September 1955, Eugenio Montale
- 11 *L'Angelo di fuoco sarà radioteletrasmesso*  
Gazzettino-Sera, 12-13 September 1955, Telemaco
- 13 *'L'angelo di fiamma', opera inedita di Prokofiev*  
L'Unità, 15 September 1955, Massimo Mila

- 14 *L'angelo di fuoco*  
Il contemporaneo, 24 September 1955, Fedele d'Amico
- 15 *Il mondo surreale di Prokofiev*  
Tempo, 29 September 1955, Guido M. Gatti
- 16 *Nel libretto dell'Angelo di fiamma' si divulgano letali errori teologici*  
L'Avvenire d'Italia, 14 September 1955, A. Vardánega

## Panel

Attic for *The Fiery Angel*, Luciano Damiani, 1955  
Tempera on cardboard, 34x51.5 cm

Count Henry's house for *The Fiery Angel*, Luciano Damiani, 1955  
Tempera on cardboard, 34.5x50.8 cm

## Music excerpt

*The Fiery Angel*, Sergei Prokofiev, 1955

## 2.7C The 1950s in dance: New York City Ballet, *The Miraculous Mandarin*, and Aurel Milloss

The postwar period opened the door to American-style choreography and the French/Russian school, while the relationship with Ausdruckstanz, the Central European tradition of modern expressive dance that hybridised ballet with narrative expression, also remained active.

The American National Ballet performed in 1950 and the Grand Ballet du Marquis de Cuevas in 1950 and 1957. The New York City Ballet also took the stage at Teatro La Fenice in 1953 and 1956, showcasing the originality of George Balanchine's neoclassical, concerto-like ballets, Jerome Robbins' many-sided, polymorphic ingenuity, and the "psychological" work of Antony Tudor, who later taught Pina Bausch.

In 1955 Jean-Jacques Etcheverry, who had trained with Lydia Karpova and Nicolas Zverev and danced with the Diaghilev-inspired Nouveaux Ballets de Monte-Carlo, created the unsettling *Il Mandarino meraviglioso* (*The Miraculous Mandarin*). Choreographed to music by Béla Bartók, it was performed at La Fenice by dancers from Théâtre Royal de la Monnaie in Brussels. A pantomime in one act, its central character is a girl forced by exploitative individuals to seduce men who are then attacked and robbed. A very rich Chinese man manages to withstand their violence, dying and giving up his gold only at the climax of pleasure. In the pro-Nazi Germany of 1926, after a preview in Cologne, the work was banned on the grounds of immorality and debuted instead at Teatro della Scala, in the Fascist Italy of 1942, with Aurel Milloss's choreography and sets and costumes by Enrico Prampolini. La Biennale di Venezia became a great supporter of the work of Rudolf Laban's pupil Aurel Milloss (1906-1988), a modern observer of the human body in performances focusing on strength, weight, time, space, form and flow, which are elements of all human action, including dance. Given his penchant for interdisciplinary partnerships with high-profile painters and musicians, in 1948 Milloss was invited to Venice for projects entrusted to the Balletto dell'Opera in Rome and, in 1950, became director and choreographer of classical and modern pieces for La Biennale's own dance company. EGV

- 2 Letter sent by L. Leonido to Rodolfo Pallucchini, 15 June 1953 (transcription)
- 3 New York City Ballet, George Balanchine's portrait
- 4 *Arriva in Italia il balletto di New York. Il famoso complesso diretto da Balanchine darà spettacolo in sette città italiane*  
Oggi, 27 August 1953, Teodoro Celli
- 5 Registered mail to Leonido, (s.d.)
- 6 New York City Ballet, *Age of Anxiety*, Jerome Robbins  
Photo Studio Giacomelli
- 7 Maria Tallchief, New York City Ballet, *Scotch Symphony*, George Balanchine
- 8 *Ottima esibizione del New York City Ballet*  
Il Paese, 25 September 1953, Riccardo Redi
- 9 New York City Ballet, Patricia Wilde's portrait  
Photo Walter E. Owen
- 10 *Un invito alla danza*  
La Voce Repubblicana, 15 September 1956
- 11 *I balletti di Balanchine a Venezia*  
L'Unità, 20 September 1956, Rubens Tedeschi
- 12 *Applauditi balletti presentati da Balanchine*  
Il Resto del Carlino, 19 September 1956, Duilio Courir
- 13 *I balletti di New York a Venezia*  
L'Unità, 20 September 1956, Rubens Tedeschi
- 14 *Una mirabile danza macabra su un festival nato morto*  
L'Avanti!, 19 September 1956, Luigi Pestalozza
- 15 *Riuscite caricature della musica. I due lavori più validi del Festival*  
L'Unità, 24 September 1956, Rubens Tedeschi
- 16 Dolores Laga and Pierre Pauwels, *The Miraculous Mandarin*,  
Jean-Jacques Etcheverry, 1955. Photo Studio Giacomelli
- 17 Dolores Laga, *The Miraculous Mandarin*, Jean-Jacques Etcheverry, 1955.  
Photo Studio Giacomelli
- 18 *The Miraculous Mandarin*, Jean-Jacques Etcheverry, 1955.  
Photo Henri Vermeulen
- 19 *Bartok, Malipiero e Milhaud sotto la direzione di Franz André*  
L'Avanti!, 14 September 1955, Luigi Pestalozza
- 20 *Il mandarino meraviglioso di Bartok rappresentato ieri sera al Teatro La Fenice*  
Il Resto del Carlino, 14 September 1955, Duilio Courir
- 21 Andre Leclair, *Il mandarino meraviglioso*, Jean-Jacques Etcheverry, 1955.  
Photo Studio Giacomelli
- 22 Dolores Laga and Mario Ohn, *The Miraculous Mandarin*,  
Jean-Jacques Etcheverry, 1955
- 23 **Ipad**  
*La nimphe de Diane*, Aurel Millos, 1948.  
Photo Interfoto
- La nimphe de Diane*, Aurel Millos, 1948  
Photo Studio Giacomelli
- Marsia*, Aurel Millos, 1948. Photo Interfoto
- Orpheus*, Aurel Millos, 1948. Photo Studio Giacomelli
- Orpheus*, Aurel Millos, 1948. Photo Interfoto
- Angelo della morte*, sketch by Fabrizio Clerici Orpheus, Aurel Millos, 1948
- Ancora aperto il 'caso Stravinsky'*  
La Repubblica d'Italia, 12 September 1948
- XI Festival Internazionale di Musica*  
Radiocorriere, 29 August, 4 September 1948
- Ballata senza musica*, Aurel Millos, 1950. Photo Studio Giacomelli
- Il principe di legno*, Aurel Millos, 1950. Photo Studio Giacomelli

## Panel

- 'The mandarin' for *The Miraculous Mandarin*, Jean Pierre Ponnelle, 1955  
tempera on paper, 30.8x22.6 cm
- 'The noble knight' for *The Miraculous Mandarin*, Jean Pierre Ponnelle, 1955  
tempera on paper, 30.8x22.5 cm
- 'The girl' for *The Miraculous Mandarin*, Jean Pierre Ponnelle, 1955  
tempera and China ink on paper, 30.8x22.9 cm
- 'Vagabond' for *The Miraculous Mandarin*, Jean Pierre Ponnelle, 1955  
tempera on paper, 30.6x22.7 cm

## 2.8 Bertolt Brecht: ideological censorship

In 1951 Bertolt Brecht was invited by La Biennale di Venezia to stage one of his most famous works, *Mutter Courage und Ihre Kinder* (Mother Courage and Her Children). However, the Italian government refused to issue visas to him and his Berliner Ensemble because they were coming from communist East Germany. At the time the Berliner Ensemble was already one of Europe's most important companies and the play's cancellation brought a heated response from Italian politicians and intellectuals like Giulio Einaudi and Luchino Visconti, with the latter threatening to withdraw his own plays (Diego Fabbri's *Il seduttore* and Arthur Miller's *Death of a Salesman*). Ten years later, in 1961, a second attempt to host Brecht at the Biennale also failed; the great German artist had planned to stage *The Resistible Rise of Arturo Ui* and, once again, *Mother Courage*, with the Berliner Ensemble. But after initial openness to the ensemble's visit, at the last minute the Italian government decided against granting them a visa in an attempt to reassure the country regarding its political approach to the German Democratic Republic. It was a form of censorship which risked compromising the very existence of the Biennale Teatro and was probably one of the most dispiriting examples of political interference in Italian cultural life. FB

### Blow-up

Poster for *Madre Coraggio e i suoi figli*, by Bertolt Brecht, 1947.

### Panel

Poster for the 14th International Festival of Contemporary Music and the International Theatre Festival, 1951

- 1 Bertolt Brecht's biography, 1961
- 2 *Madre Coraggio e i suoi figli* typewritten report, 1961
- 3 Letter from Paolo Grassi to Adolfo Zajotti, 12 February 1951
- 4 Estimate for *Madre Coraggio* by Bertolt Brecht, 1951
- 5, 6, 7 *Madre Coraggio e i suoi figli*, by Bertolt Brecht, 1961
- 8 *Madre Coraggio* typewritten report, by Bertolt Brecht in Italy
- 9 Collage of two German texts, Bertolt Brecht, 1961
- 10 Letter from Adolfo Zajotti to Gerardo Guerrieri, 10 January 1951
- 11 Letter from Helene Weigel to Adolfo Zajotti, 8 June 1951 (Italian translation)
- 12 Bertolt Brecht and Francois Maistre
- 13 Letter from Helene Weigel to Adolfo Zajotti, 8 June 1951 (German original)
- 14 Letter from Giovanni di Giura to Adolfo Zajotti, 4 September 1951
- 15 20th International Theatre Festival programme's typewritten draft
- 16 *Teatro rosso e governo nero*  
Il Popolo nuovo, 21 June 1951, Carlo Trabucco
- 17 Letter from Adolfo Zajotti to Giovanni di Giura, 6 September 1951
- 18 Press release, 21 September 1951
- 19 Letter from Giovanni di Giura to Adolfo Zajotti, 8 September 1951
- 20 Letter from Luchino Visconti to La Biennale's Head office, 17 September 1951
- 21 Telegram from Giovanni Ponti to Rodolfo Pallucchini, 20 September 1951
- 22 Letter from the President Giovanni Ponti to Luchino Visconti, 18 September 1951

- 23 Letter from Rina Morelli, Luchino Visconti, Paolo Stoppa to the House of Representatives, 21 September 1951
- 24 Telegram from Helene Weigel to Adolfo Zajotti, 1951 (Italian translation)
- 25 *Visconti protesta contro il veto a Brecht*, L'Unità, 18 September 1951
- 26 Letter from the Administrative Director Giovanni Piccini to Luchino Visconti, 19 September 1951
- 27 *Il Governo pensa al Teatro. La censura si diverte* Corriere lombardo, 18 September 1951, Carlo Terron
- 28 *Visconti toglie il nome dagli avvisi del Festival* L'Europeo, 30 September 1951, Raul Radice
- 29 *Disco Rosso per l'arte all'insegna della politica* Panoramiche, 29 September 1951, Giovanni Calendoli
- 30 *Vorrebbero una censura che facesse rima con dittatura* Il Popolo, 19 June 1951, Carlo Trabucco
- 31 *L'Editore Einaudi denuncia questo grave atto di inciviltà* L'Unità, 19 September 1951, Giulio Einaudi
- 32 *Recita la Spagna e si parla solo di Brecht* L'Unità, 18 September 1951, Giulio Trevisani
- 33 *Un gesto che offende la cultura italiana* L'Unità, 3 October 1951, Luciano Lucignani
- 34 *Paura di Madre Coraggio* Il Lavoro, 13 October 1951, Luciano Lucignani
- 35 *Brecht al rogo* L'Unità, 10 September 1961

## 2.9 The Visconti case

The Cold War was also fought offstage at the festival and it was Luchino Visconti, often called the “Red Count” for his allegiance to the Communist Party, who paid the highest price. In 1948 his Neorealist masterpiece *La terra trema* was booed in the Sala Grande. Part of the festival’s jury argued that Visconti’s film showed “arbitrary distortions of an essentially political nature” and granted him only a minor award, with Laurence Olivier’s *Hamlet* winning the prize. 1948 also saw the desertion of the USSR – until 1952 – with Hollywood dominating the festival programme in those years. Aesthetic “battle lines”, not without political overtones, were soon drawn between the schools of Fellini and Visconti, and in 1954, the Golden Lion went to Renato Castellani’s inoffensive *Romeo and Juliet* and a Silver Lion to Federico Fellini’s *La strada*. Visconti’s *Senso* was totally ignored. Mayhem broke out at the award ceremony in the Sala Grande: Visconti’s assistant Franco Zeffirelli got in a physical fight with Fellini’s assistant Moraldo Rossi, and the police had to intervene to separate them, while *La strada*’s producer Dino De Laurentiis engaged in a shouting match with Visconti supporters. In 1954 Luigi Chiarini wrote that festival director Ottavio Croze’s film selection had been deemed too left-wing by the pro-governmental press: “The red flag is flying over the Lido cinema hall!” In 1960 audiences took issue with *Rocco e i suoi fratelli* (shouting “Enough with these films about poverty, crime and whores!”) and Visconti recalled three Christian Democrat ministers commenting after the screening: “It’s disgusting, a disgrace, a film that must not win any prizes!” *Rocco e i suoi fratelli* won only the Special Jury Prize, while the Golden Lion went to André Cayatte’s *Le passage du Rhin*. GG

## Blow-up

From the set of *Senso* by Luchino Visconti, 1954

## Monitor

*Senso* by Luchino Visconti, 1954

*Rocco e i suoi fratelli* by Luchino Visconti, 1960

- 1, 2, 6-8 *Senso* by Luchino Visconti, 1954  
Archive Cameraphoto Epoche /© Vittorio Pavan
- 3 *Giulietta e Romeo il capolavoro di Castellani segna a Venezia il trionfo del cinema italiano*  
Roma, 12 September 1954, Paolo di Valmarana
- 4 *A Venezia Leoni ammaestrati*  
Roma, 19 September 1954, Emilio Tadini
- 5 Rivista Cinema, n. 139, private Collection
- 9, 14 Luchino Visconti, 1965. Photo Cameraphoto
- 10 Luchino Visconti, Claudia Cardinale, Jean Sorel, 1965. Photo Cameraphoto
- 11 Luchino Visconti, Maria Callas, Photo Studio Giacomelli, private Collection
- 12 Luchino Visconti, Francesco Rosi, Alida Valli, 1969. Photo Cameraphoto
- 13 Luchino Visconti, Marcello Mastroianni, 1957. Photo Cameraphoto
- 15 *Epilogo del Festival di Venezia - Fischi al verdetto*  
Corriere d’informazione, 8 September 1960
- 16 *Venezia: verdetto incredibile - Cayatte preferito a Visconti*  
La Giustizia, 8 September 1960, Marcello Clemente
- 17 *Vergognoso verdetto alla mostra di Venezia. Uragano di fischi per il premio a Cayatte*  
Il Lavoro Nuovo, Genova, 8 September 1960, Lino Micciché
- 18 *Scandalo a Venezia: Visconti escluso*  
Paese Sera, 8 - 9 September 1960, Maurizio Liverani
- 19 *Lo spettacolo più divertente, la caotica serata della premiazione*  
Il Messaggero, 9 September 1960, Guglielmo Biraghi
- 20 *Il troppo sicuro Visconti si è visto sfuggire il “Leone”*  
Espresso Sera, 8 September 1960
- 21 *Rocco e i suoi fratelli* by Luchino Visconti, 1960  
Renato Salvatori, Corrado Pani  
Photo G.B. Poletto
- 22 *Rocco e i suoi fratelli ha messo a rumore l’Italia dello spettacolo - Un baccanale di sangue*  
Il Tirreno, 21 October 1960, Riccardo Marchi
- 23 *Rocco e i suoi fratelli* by Luchino Visconti, 1960  
Alain Delon, Annie Girardot
- 24 *Rocco e i suoi fratelli* by Luchino Visconti, 1960  
Alain Delon, Corrado Pani, Nino Castelnuovo
- 25 *Rocco e i suoi fratelli* by Luchino Visconti, 1960  
Claudia Cardinale
- 26 *Rocco e i suoi fratelli* by Luchino Visconti, 1960  
Suzy Delair, Renato Salvatori  
Photo G. B. Poletto
- 27 *Rocco e i suoi fratelli* by Luchino Visconti, 1960  
Renato Salvatori  
Photo G. B. Poletto
- 28, 29, 31 *Rocco e i suoi fratelli* by Luchino Visconti, 1960  
Photo Paul Ronald
- 30 *Rocco e i suoi fratelli* by Luchino Visconti, 1960  
Photo G. B. Poletto
- 32, 38 *Rocco e i suoi fratelli* by Luchino Visconti, 1960
- 33 *Rocco e i suoi fratelli* by Luchino Visconti, 1960  
Renato Salvatori
- 34 *Rocco e i suoi fratelli* by Luchino Visconti, 1960  
Claudia Cardinale, Nino Castelnuovo
- 35 *Rocco e i suoi fratelli* by Luchino Visconti, 1960  
Annie Girardot
- 36 *Rocco e i suoi fratelli* by Luchino Visconti, 1960  
Renato Salvatori  
Photo G. B. Poletto
- 37 *Rocco e i suoi fratelli* by Luchino Visconti, 1960  
Annie Girardot, Renato Salvatori  
Photo G. B. Poletto



## 2.10A Exhibitions abroad

After World War Two La Biennale also went back to organising and participating in exhibitions abroad. The first event was held, not coincidentally, in what was then Europe's richest country and one which had not suffered significant damage during the war: Switzerland. The intention was to promote Italian art abroad, so the group exhibition *Quarant'anni d'arte italiana dal futurismo ai nostri giorni* (Forty Years of Italian Art, from Futurism to the Present) was held first in Lausanne and then in Lucerne from February to June 1947. Even before the exhibition opened, Italian newspapers began stirring up controversy over the selection of artists. Certain members of the board resigned and the decision was made to change the title to *Mostra di artisti italiani contemporanei dal futurismo ad oggi 1909-1946* (Exhibition of Contemporary Italian Artists from Futurism to Today, 1909-1946). In 1951 the Biennale became an exhibition model to emulate and its first "twin" was held in the Brazilian metropolis of São Paulo. Italian participation in the first São Paulo Biennial was officially entrusted to La Biennale di Venezia, which also offered advice and assistance on overall organisation. Given Brazil's large Italian community, which included São Paulo Biennial founder Ciccillo Matarazzo, the participation of Italian artists was a great success in terms of both revenue and publicity throughout the 1950s. La Biennale's initiatives abroad multiplied, with other exhibitions being held in Alexandria, Stockholm, Tokyo and other parts of the world until the mid-1970s. VP

### Blow-up

- Visual Arts exhibition, Stockholm, 1953
- 1-6, 9 *Quarant'anni d'arte italiana dal futurismo ai nostri giorni*, Losanna, 1947. Photo Presse Diffusion Lausanne
- 7 *Baru a per la mostra degli artisti contemporanei* Il Giornale, 10 February 1947, Franco Bondioli
- 8 *L'incompiuta di Losanna* Corriere Lombardo, 30 March 1947
- 10 *Artistas italianos de hoje* Catalogue of the 1st São Paulo Art Biennial, 1951
- 11 Rodolfo Pallucchini and Umbro Apollonio studying the staging of the 1st São Paulo Art Biennial, 1951
- 12 Press release *Il successo della mostra d'arte italiana a Stoccolma*, 14 March 1953
- 13 *Arte Italiana in Svezia* Il Corriere di Trieste, 6 March 1953
- 14 Visual Art Exhibition, Stockholm, 1953. Photo Olof Ekberg
- 15, 16, 18 Visual Art Exhibition, Stockholm, 1953
- 17 *La Biennale a Stoccolma* L'Unità, 18 March 1953, by Luigi Ferrante
- 19 *Artistas italianos de hoje* Catalogue of the 4th São Paulo Art Biennial, 1957
- 20 4th São Paulo Art Biennial, Notification card of Leoncillo Leonardi's artworks, 1957
- 21 4th São Paulo Art Biennial, Notification card of Renato Guttuso's artworks, 1957
- 22 4th São Paulo Art Biennial, Notification card of Gino Severini's artworks, 1957
- 23 Poster of the *Italian Contemporary Sculpture* exhibition, Tokyo, 1961
- 24 Press review, Mainiki Newspapers, 20 January 1961
- 25-27, 30 *Italian Contemporary Sculpture*, Tokyo, 1961

28 *Italian sculpture exhibition begins*  
The Mainiki Daily News, 17 January 1961

29 *Sculpture that focus today's art*  
The Mainiki Daily News, 26 January 1961, by Thomas T. Ichinose

## 2.10B Robert Rauschenberg's award, 1964

1964 was the year that Italy and the United States risked a diplomatic incident over the Biennale, but was also a watershed moment in which American art came to the fore and abstract painting turned into the standard bearer of Western liberalism in Europe. The curator of the US pavilion was Alan Solomon, previously director of New York's Jewish Museum, and in the words of Italian-American gallery owner Leo Castelli, he "put together the best things to be found in American art after the great period of Abstract Expressionism".

A lack of space meant that the work of the eight exhibiting artists – Jim Dine, Jasper Johns, Morris Louis, Kenneth Noland, Robert Rauschenberg, Frank Stella, John Chamberlain and Claes Oldenburg – was shown at two different sites: the American pavilion in the Giardini and the former US consulate at San Gregorio in Venice. The decision to exhibit work at two sites was taken after a heated exchange of letters between the US cultural attaché Michael Barjansky, the American curator, and La Biennale.

It was clear right away that the pavilion space was too small for all the work selected, but President Mario Marazzan and Secretary Gian Alberto Dell'Acqua vetoed all suggestions that an exhibition held outside the Giardini could be considered an integral part of the Biennale. Such a concession, it was felt, would have been difficult to justify with other nations and would have set a precedent.

The organisers thus recommended including one work per invited artist at the Giardini, so that all would be represented and eligible for the jury award. With a great deal of difficulty – the correspondence shows all kinds of disagreements, with Barjansky even threatening to withdraw the US from the Biennale – a compromise was found: a sign would be posted at the entrance to the pavilion to ensure that visitors would see both exhibitions.

The exhibition at the former consulate opened to great acclaim at the same time as the Biennale, and rumours were soon circulating that Rauschenberg might win an award even though his work was not actually on display at the Giardini. In an interview published in the 1988 catalogue *Ugo Mulas: Vent'anni di Biennale 1954-1972*, Dell'Acqua recalled: "When it became a question of awarding the prize to Rauschenberg, two of his paintings had to be brought to the Giardini to justify his presence at the Biennale". To make the award possible in accordance with the rules, Solomon decided, at the very last minute, to move the work from the consulate and exhibit it outside the pavilion at the Giardini, under a plastic roof to protect it from the weather. MP

- 1 Letter from Mario Marazzan to Michael Barjansky, 27 March 1964
- 2 Letter from Gian Alberto Dell'Acqua to Alan Salomon, 16 April 1964
- 3 *Flying the flag for Art: The United States and the Venice Biennale, 1895 – 1991*  
Philip Rylands and Enzo di Martino, 1993
- 4 Beatrice Monti, Robert Rauschenberg and Leo Castelli, 1964  
Photo Ugo Mulas © Eredi Ugo Mulas  
Courtesy Archivio Ugo Mulas, Milano - Galleria Lia Rumma, Milano/Napoli
- 5 Transportation of Robert Rauschenberg's artworks in the lagoon, 1964.  
Photo Ugo Mulas © Eredi Ugo Mulas  
Courtesy Archivio Ugo Mulas, Milano - Galleria Lia Rumma, Milano/Napoli
- 6 Letter from Michael Barjansky to Mario Marazzan, 7 April 1964
- 7 Public board's draft, United States of America pavilion, 1964
- 8 Letter from Mario Marazzan to Michael Barjansky, 9 April 1964
- 9 Memorandum about the United States of America's participation, 1964
- 10 Telegram from Michael Barjansky to Mario Marazzan, 11 May 1964
- 11 Transportation of Robert Rauschenberg's artworks, 1964.  
Photo Ugo Mulas © Eredi Ugo Mulas  
Courtesy Archivio Ugo Mulas, Milano - Galleria Lia Rumma, Milano/Napoli
- 12 Transportation of Robert Rauschenberg's artworks, 1964.  
Photo Ugo Mulas © Eredi Ugo Mulas  
Courtesy Archivio Ugo Mulas, Milano - Galleria Lia Rumma, Milano/Napoli
- 13 Robert Rauschenberg and Jasper Johns's room, 1964.  
Photo Ugo Mulas © Eredi Ugo Mulas  
Courtesy Archivio Ugo Mulas, Milano - Galleria Lia Rumma, Milano/Napoli
- 14 Robert Rauschenberg and Alan Solomon, 1964.  
Photo Ugo Mulas © Eredi Ugo Mulas  
Courtesy Archivio Ugo Mulas, Milano - Galleria Lia Rumma, Milano/Napoli
- 15 Robert Rauschenberg's room, 1964.  
Photo Ugo Mulas © Eredi Ugo Mulas  
Courtesy Archivio Ugo Mulas, Milano - Galleria Lia Rumma, Milano/Napoli
- 16 Robert Rauschenberg's award ceremony, 1964.  
Photo Ugo Mulas © Eredi Ugo Mulas  
Courtesy Archivio Ugo Mulas, Milano - Galleria Lia Rumma, Milano/Napoli

## 2.10C Luigi Nono, *Intolleranza 1960*, 1961

*Intolleranza 1960* (Intolerance 1960) marked a key moment in postwar music history. It was one of the first operas composed by a member of the neo-avant-garde group that had emerged from the Darmstadt summer school (Ferienkurse) and above all, the first response to the demands for a new type of musical drama that Luigi Nono continued to explore throughout the 1950s. Fuelled by a strong political and ideological impulse (Nono had joined the Italian Communist Party in 1952), these demands focused on developing a "theatre of ideas" that would be totally committed at the social, structural and linguistic level, contemporary in its genuinely topical nature, and compelling in its defense of human dignity. Based on an idea of Angelo Maria Ripellino's, this "two-part action for the stage" was commissioned by the artistic director of the Biennale's Music Department, Mario Labroca, in 1960. The first performance on 13 April 1961 at Teatro La Fenice, directed by Vacláv Kašlík with Emilio Vedova's scenery and costumes, Josef Svoboda's technical direction and Bruno Maderna's musical direction, was interrupted by neofascists and had repercussions even in the political arena. Its critical reception was extremely mixed, in a debate that necessarily went beyond the artistic and theatrical aspects.

*Intolleranza 1960* is grounded in a dialectic tension that permeates every aspect, both thematic and structural.

The task of coming to terms with history and the present is reflected in the dialectical relationship between individual and community, as well as between author and audience. Nono conceived the work as a dynamic, complex construction where different musical and theatrical elements interact in varying configurations: the action, singing, orchestra, visual images, and the spaces of the stage and audience interweave in a drama that even makes use of projections and electronic elements on tape. The music reveals the multiplicity of compositional techniques, both vocal and instrumental, used by Nono throughout the 1950s, which here sometimes accompany or contrast with one another in a powerfully experimental tension: aspects such as seriality, a sculptural treatment of sound and text, a residual but intense lyricism, a differentiated use of the orchestra, and the incorporation of electronics. CF

### Panel

- Sixth scene - end of the 1st part for *Intolleranza 1960*, Emilio Vedova, 1961  
Mixed technique on scenery paper glued onto black canvas, 49.5x71.5 cm
- 1 24th International Festival of Contemporary Music programme, Venice, 9-27 April 1961 (German version)
  - 2 Letter from Luigi Nono to Mario Labroca, 30 November 1960
  - 3 24th International Festival of Contemporary Music programme, Venice, 9-27 April 1961 (Italian version)
  - 4 Emilio Vedova, *Intolleranza 1960*, Luigi Nono, 1961
  - 5 Programme of *Intolleranza 1960*, 13 and 15 April 1961
  - 6 *Intolleranza 1960*, Luigi Nono, 1961. Photo Reporter Servizi fotografici
  - 7,9,10,13 *Intolleranza 1960*, Luigi Nono, 1961. Photo Studio Ferruzzi
  - 8 List of the Italian critic's judgements related to the XXIV International Festival of Contemporary Music, 1961
  - 11 *Intolleranza 1960*, Luigi Nono, 1961. Photo Foto film
  - 12 *Nono's opera for Venice*  
The Times, 23 March 1961
  - 14 Centro Studi Ordine Nuovo's flyer thrown at Teatro La Fenice the night of 13 April 1961 during the premiere of *Intolleranza 1960*
  - 15 Ordine Nuovo's flyers' throw against *Intolleranza 1960*, Luigi Nono, 1961. Photo Studio Ferruzzi
  - 16 *Intolleranza 1960 conquista il pubblico*  
L'Avanti, 14 April 1961, Luigi Pestalozza
  - 17 *Applausi e fischi a Venezia per Intolleranza 1960*  
Paese sera, 14-15 April 1961, Piero Dallamano
  - 18 *Prima mondiale a Venezia dell'Intolleranza '60'*  
Corriere di informazione, 14/15 April 1961, Eugenio Montale
  - 19 *Intolleranza 1960 Opéra de Luigi Nono*  
Le Monde, 16-17 April 1961, Claude Rostand
  - 20 *Die skandalöse Intoleranz*  
Christ und welt, 21 April 1961, Claus-Henning Bachmann
  - 21 *Intolleranza 1960 di Luigi Nono suscita un pandemonio alla Fenice*  
Il Secolo XIX, 15 April 1961, Mario Rinaldi
  - 22 *Intolleranza 1960 alla Fenice*  
L'Unità, 14 April 1961, Giacomo Manzoni
  - 23 *Anatomia del nostro tempo*  
L'Espresso, 23 April 1961, Massimo Mila
  - 24 *Pacefisti, Fascisti und ein Opern-Experiment*  
Deutsche Zeitung, 17 April 1961, Heinrich Lindlar
  - 25 *Nono's High Praise for BBC Orchestra*  
The Times, 13 April 1961

Music excerpt *Intolleranza 1960*, Luigi Nono, 1961

# ROOM 3

## 1968: A YEAR OF PROTESTS AND NEW IDEALS

1968 was the year of protests: just a few days before the Biennale Arte opened, students occupied their universities and art academies and took to the streets to demonstrate in support of the Prague Spring. Seen as a symbol of bourgeois culture, with an anachronistic statute, the Biennale became the demonstrators' primary target. The authorities worried about the potential for disruptions after the Triennale in Milan was occupied in May. Calls to postpone the opening of the 34th International Art Exhibition came in from various sides, but Venetian businesses insisted that the event should start as planned to avoid jeopardising the tourist season. Meanwhile, Giuseppe Mazzariol, Arnaldo Pomodoro and Giuseppe Santomaso resigned from the figurative arts subcommittee and a number of artists sent telegrams to La Biennale to withdraw their work. Youth protests in Piazza San Marco, led by composer Luigi Nono and painter Emilio Vedova, were put down by the police and the headlines read: "The Biennale of Truncheons". A great many critics and foreign journalists were caught up in the ensuing scuffles. On 18 June there was an unprecedented police presence at the entrance, creating a general climate of tension. Inside, on the other hand, the Giardini looked deserted, with most national pavilions closed. Many of the Italian artists, including Lorenzo Guerrini and Gastone Novelli, turned their paintings to the wall in support of the demonstrators, and some even went so far as to write "Fascist Biennale" on the back of their work. The prize winners for 1968 included optical painter Bridget Riley and cybernetic sculptor Nicolas Schöffer. Among the Italians, Gianni Colombo presented his *Spazio elastico* and Pino Pascali, who died tragically a month before the end of the Biennale, brought a playful room of objects covered in plastic matting, steel wool and chicken feathers. The 1968 protests ushered in significant changes to the Biennale Arte: the grand prizes were abolished (until 1986), and the sales office was turned into a "sales service" before being definitively closed in 1973. VP

### **The protests at the Venice Film Festival**

On 25 August 1968, on the opening night of the 29th Venice International Film Festival, the lights at the Palazzo del Cinema were switched off and its blinds

were pulled down. A line of police officers held back the group of protestors outside; they were demanding the resignation of Luigi Chiarini, who had been the director since 1963, and that the festival be self-managed by participants. Some critics and directors from the Associazione Italiana Autori Cinematografici (ANAC – Italian Association of Filmmakers) – Liliana Cavani, Marco Ferreri, Ugo Gregoretti, Francesco Maselli, Pier Paolo Pasolini, Gillo Pontecorvo and Cesare Zavattini – backed the students. "Down with the culture of the powerful!" became their slogan. Chiarini and "his" festival had drawn up a programme that included Carmelo Bene's *Nostra Signora dei Turchi*, Bernardo Bertolucci's *Partner*, Gian Vittorio Baldi's *Fuoco!*, Alexander Kluge's *Die Artisten in der Zirkuskuppel: ratlos* (which won the Golden Lion), John Cassavetes' *Faces*, Miklós Jancsó's *Csend és kiáltás* and Pier Paolo Pasolini's *Teorema*. The opening night was cancelled and the festival began two days later. At the end of it, Luigi Chiarini was forced to resign. In 1972-73, ANAC organised the Giornate del Cinema Italiano, an alternative festival held at Cinema Olimpia, in Campo Santa Margherita and at the Marghera factories. It was a sort of general assembly in which Jean-Luc Godard, Marco Ferreri, Bernardo Bertolucci, Gian Maria Volonté and Marco Bellocchio all took part, with Bellocchio presenting a preview of *Nel nome del padre*. The Venice Film Festival closed down in 1972 until a new statute could be adopted, which happened only in 1974. The epilogue to the 1968 movement came along in 1974 in the form of friction over Michelangelo Antonioni's *Chung Kuo, Cina*: Carlo Ripa di Meana, the new president of La Biennale, and Giacomo Gambetti, director of the Cinema Department, wanted to screen it at Teatro La Fenice, but this brought complaints from the Chinese government and from Mao supporters in Italy who considered the film a provocation. Umberto Eco recalled that "at the last moment the Venice prefect came to the aid of the Beijing regime and suddenly discovered that La Fenice was unfit for use as a cinema". The screening took place at Cinema Olimpia, but was besieged by protestors. GG

# ROOM 3

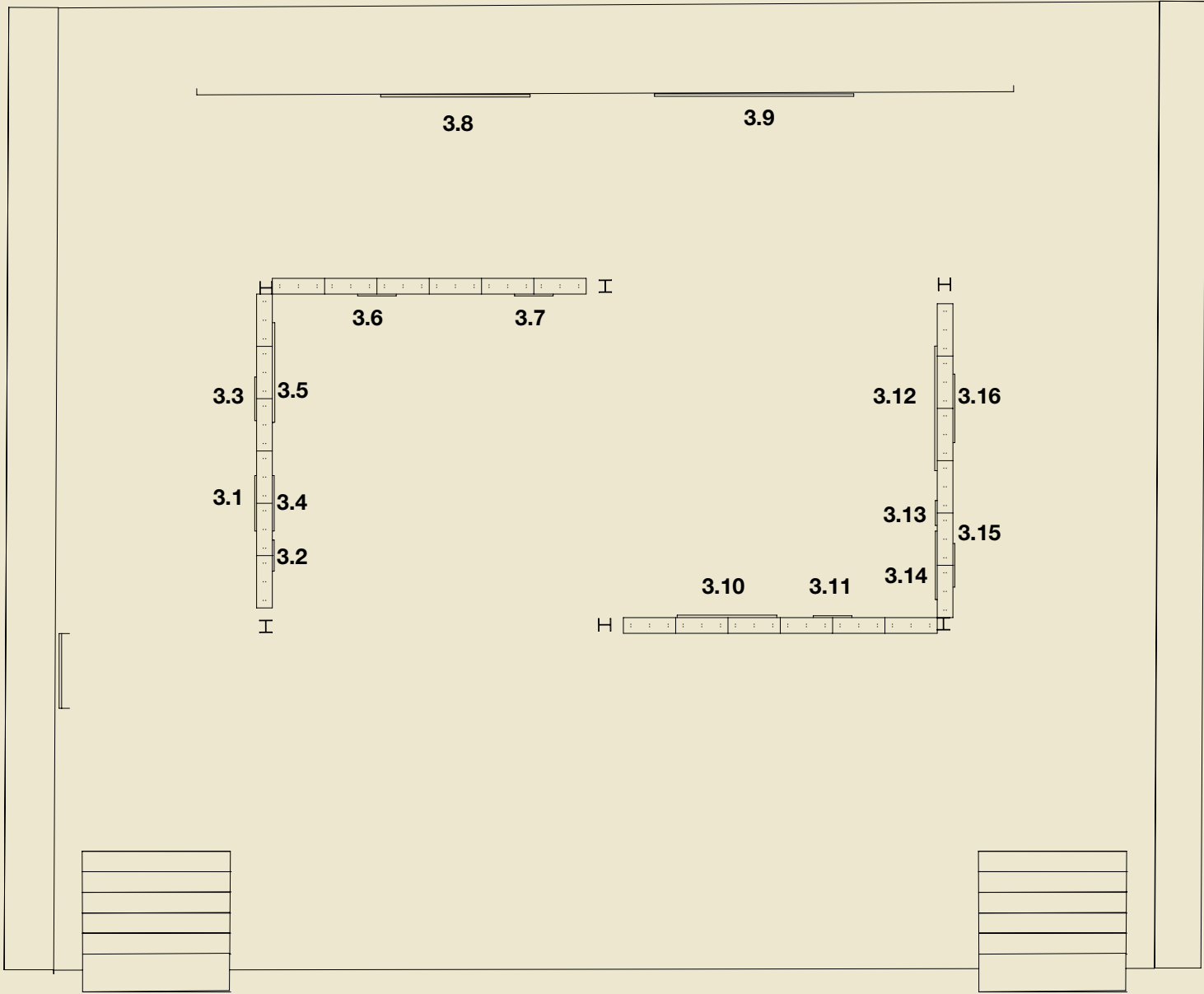

## 3.1 Student demonstrations in the spring of '68

The months before the opening of the 24th International Art Exhibition brought a string of demonstrations in cities across Italy and France. By the time of the opening, on 18 June 1968, the art academy in Venice had been occupied off and on by students for over two months. The art students were protesting against the bourgeois system, and against a Biennale they saw as elitist and cut off from the city. MP

"Sandwich-man" with protest sign 'Johnson non rompere i padiglioni!' during the demonstration, Riva degli Schiavoni, 1968  
Photo Cameraphoto Modena

Student demonstration, "sandwich-men" with protest signs during the demonstration, Piazza San Marco, 1968  
Photo Cameraphoto Modena

Protesters with protest signs during the demonstration, Procuratorie Nuove, Piazza San Marco, 1968. Photo Cameraphoto Modena

Protesters' crowd with protest sign during the student demonstration, 1968.  
Photo Cameraphoto Modena

Protest in Venice, 1968  
Istituto Veneziano per la Storia della Resistenza e della Società Contemporanea

Protests, 1968. Photo Cameraphoto Venezia

Students protest with protest signs during the demonstration, 1968  
Photo Cameraphoto Modena

Police officers outside the Giardini della Biennale during the protest, 1968  
Photo Cameraphoto Modena

Emilio Vedova discusses with some police officers during the demonstrations, Giardini della Biennale, 1968  
Photo Cameraphoto Modena

Crowd of demonstrators during the protest, 1968  
Photo Cameraphoto Modena

Students protest with protest signs confronted by the police during the demonstration, 1968  
Photo Cameraphoto Modena

Deployment of police officers during the protest, 1968  
Photo Cameraphoto Modena

Demonstration in Venice, 1968. Istituto Veneziano per la Storia della Resistenza e della Società Contemporanea

Luigi Nono during the protests, 1968. Photo Reporter

Luigi Nono during the protests, 1968. Photo Studio Ferruzzi

Disputes and demonstrations during the opening of the 34th International Art Exhibition, 1968.  
Photo Reporter

Disputes and demonstrations at the Giardini della Biennale, 1968.  
Photo Studio Ferruzzi

Luigi Nono, Emilio Vedova and Carlo Scarpa during the protests at the Giardini della Biennale, 1968. Photo Studio Ferruzzi

The police charges the demonstrators in front of the Caffè Florian, 1968

## 3.2 Concerns about the safety of the art and growing tensions

The occupation of the Milan Triennale came two weeks before the opening of Biennale Arte and the news of damage to its artworks frightened Biennale lenders. The organisers received telegrams asking them to either provide reassurance about the precautions adopted to protect the work, or return it immediately. In some cases lenders decided not to send the artworks at all. A week before opening, Secretary General Gian Alberto Dell'Acqua announced that only forty per cent of the work was ready for exhibition. Many other messages heightened tensions even further, including an anonymous letter warning, in capital letters, "TRY TO GET READY. THEY'RE CRAZY". There were also statements from the student movement and from a committee set up to organise a boycott, exhorting artists to desert the Biennale in the name of "a new dialogue between art forms" and to combat "the repressive structure of capital." MP

Letter to La Biennale di Venezia, 3 June 1968

Telegram from Arnaldo Pomodoro to La Biennale, 3 June 1968

Telegram from Thompson Flores to La Biennale, 5 June 1968

Telegram from Luciano Pistoì to La Biennale, 5 June 1968

Manifesto of the revolutionary students, workers and intellectuals for the boycott of La Biennale, 7 June 1968

Academies of Fine Arts Student Movement's flyer, 13 June 1968

'Benvenuto colui che viene nel nome del questore' flyer, 1968

Boycott of La Biennale Committee's flyer, 1968

## 3.3 Contested vernissage at the Giardini

In this climate of alarmism and tension, fearing that demonstrators would attack the pavilions, La Biennale management organised a police presence to protect them. The first clash took place on the morning of the vernissage, when demonstrators – including future Venice mayor Massimo Cacciari, composer Luigi Nono and artist Emilio Vedova – moved with their placards toward the Giardini gates, where "hundreds" (the exact number has never been established) of police officers in riot gear, Carabinieri and special mobile units were standing guard over the artworks and the pavilions, which were still being prepared. MP

## 3.4 The artists' protests

The massive deployment of police at the Giardini triggered a reaction from the artists, who until then had not taken up the student movement's invitation to desert the Biennale. Some blocked access to the exhibition rooms with easels and placards, others covered their work with plastic sheeting. In a gesture which later became emblematic of the whole protest, Gastone Novelli turned his paintings to the wall and wrote "The Biennale is Fascist" on the back. The Italian artists were soon emulated by foreign artists in other pavilions. On the glass front of the Swedish pavilion, someone wrote "The Biennale is Dead". MP

Gastone Novelli during the protest, 1968. Photo Studio Ferruzzi

Gastone Novelli and Gian Alberto Dell'Acqua during the protest, 1968.  
Photo Studio Ferruzzi

Gastone Novelli and Lorenzo Guerrini during the protest, 1968.  
Photo Studio Ferruzzi

Gastone Novelli's canvases exhibited upside down as a sign of protest, 1968.  
Photo Studio Ferruzzi

A moment of the protest, 1968

Undersecretary Eugenio Gatto during the opening of the 34th International Art Exhibition, 1968.  
Photo Reporter

Gian Alberto Dell'Acqua and Eugenio Gatto during the opening of the 34th International Art Exhibition, 1968. Photo Reporter

Undersecretary Eugenio Gatto during the opening of the 34th International Art Exhibition, 1968.  
Photo Studio Ferruzzi

The Nordic countries pavilion closed for the protests, 1968.  
Photo Studio Ferruzzi

The Nordic countries pavilion closed for the protests, 1968

The Nordic countries pavilion closed for the protests, 1968.  
Photo Reporter

The exterior of the Nordic countries pavilion during the protest, 1968.  
Photo Cameraphoto Modena

Interior of the Italian pavilion during the protest, 1968.  
Photo Cameraphoto Modena

Gastone Novelli inside the Italian pavilion during the protest, 1968  
Photo Cameraphoto Modena

Visitors outside the Nordic countries pavilion during the protest, 1968  
Photo Cameraphoto Modena

Interior of the French pavilion, Piotr Kowalski's room,  
during the protest, 1968  
Photo Cameraphoto Modena

French pavilion, Piotr Kowalski's room closed to visitors  
during the protest, 1968. Photo Cameraphoto Modena

The exterior of a pavilion during the protest, 1968  
Photo Cameraphoto Modena

Interior of the Italian pavilion, paintings covered with sheets of paper  
during the protest, 1968  
Photo Cameraphoto Modena

Giovanni Favaretto Fisca and Gian Alberto Dell'Acqua  
during the demonstration, 1968. Photo Cameraphoto Modena

---

## 3.5 The AAMOD protest documentary video

*Contestazione alla Biennale di Venezia 1968*,  
Archivio AAMOD, 1968 (mute)

*Biennale 1968*, b/w, sound, 1968

---

## 3.6 Withdrawal of artworks from the Biennale

**In the days following the vernissage and prior to the public opening planned for 22 June, La Biennale offices received many telegrams and letters of warning from participating Italian artists, notifying it of their intention to withdraw their work in light of the atmosphere of intimidation and repression. The president, Mayor Giovanni Favaretto Fisca, told Secretary General Dell'Acqua to take an inflexible stance, and in the correspondence one finds veiled threats of legal action if work was withdrawn. MP**

Letter from Franco Gentilini to Gian Alberto Dell'Acqua, 4 January 1968

Letter from Gian Alberto Dell'Acqua to Gastone Novelli, 8 February 1968

Letter from Gastone Novelli to Gian Alberto Dell'Acqua, 3 April 1968

Letter from Gian Alberto Dell'Acqua to Gastone Novelli, 9 April 1968

Letter from Gastone Novelli to Gian Alberto Dell'Acqua, 1968

Telegram from Gianni Colombo and Marcello Morandini to La Biennale,  
20 June 1968

Letter from Gastone Novelli to La Biennale, 20 June 1968

Telegram from Remo Brindisi, 21 June 1968

Telegram from the Unione Donne Italiane, 21 June 1968

Letter from Paul S. Newman, 8 July 1968

Letter from Paul S. Newman, translation, 8 July 1968

Letter from Giovanni Favaretto Fisca to Rodolfo Aricò, 16 July 1968

Letter from Gastone Novelli, 21 July 1968

Telegram from Rodolfo Aricò to La Biennale, 24 July 1968

Letter from Gianni Colombo and Marcello Morandini to  
Giovanni Favaretto Fisca, 25 July 1968

Letter from Deuglesse Grassi and Gian Alberto Dell'Acqua to  
Gastone Novelli, 26 July 1968

Livio Marzot's telephone announcement, 27 July 1968

Postcard to the Jury Commission of La Biennale, 1968

Letter from Gastone Novelli to Gian Alberto Dell'Acqua, 14 August 1968

Notice to the public, 1968

Flyer distributed during the demonstration, 1968

Gruppo Rivoluzionario per una Nuova Biennale's flyer, 1968

---

## 3.7 Press clippings of the vernissage

Press release, 10 June 1968

*Senza Robespierre "vernice" tranquilla?*  
Il Giorno, 18 June 1968, Nantas Salvalaggio

*Venezia, impassibile supera anche la rivolta globale*  
Il Giorno, 19 June 1968, Nantas Salvalaggio

*Fallito l'assalto alla Biennale*  
Il Gazzettino, 19 June 1968

*La Biennale non si vede ancora*  
Corriere della Sera, 19 June 1968, Dino Buzzati

*Ciò che resta della Biennale si inaugura oggi a Venezia*  
Corriere della Sera, 21 June 1968, Sandro Meccoli

*Biennale in crisi*  
Corriere della Sera, 21 June 1968, Dino Buzzati

*Giornata tesa a Venezia dopo gli scontri in Piazza*  
Il Gazzettino, 21 June 1968

*La "Biennale poliziotta" inaugurata in un clima di imbarazzo e impotenza*  
L'Unità, 24 June 1968, Mario Passi

*Tranquilla apertura a Venezia della contestata Biennale d'arte*  
Stampa sera, 25 June 1968, Gigi Ghirotti

*Gli artisti dal rifiuto all'azione*  
L'Unità, 29 June 1968, Mario De Micheli

*Ecco la "minimal art"*  
Corriere della Sera, 27 June 1968, Dino Buzzati

*Radiografia politica della "Biennale della paura"*  
Paese sera, 6 July 1968, Giulio Obici

*Poche personalità e molte compare*  
L'Avanti!, 17 July 1968, Cesare Vivaldi

*Alla Biennale: futurismo e l'ultima avanguardia*  
La Stampa, 9 August, 1968

*"Happening" alla Biennale*  
Corriere della Sera, 11 August 1968, Dino Buzzati

*Da oggi Biennale col brivido*  
17 June 1968, Dino Buzzati

---

## 3.8 Ugo Mulas's photographs

**Ugo Mulas, the legendary Italian photographer known for his depictions of the Italian and international art scene, immortalised Venice and its artists for over twenty years. In 1968 he documented the clashes between protestors and police in Piazza San Marco, and the artists' demonstrations in the Giardini. His photos show covered-up artworks and statements by Valerio Adami, Rodolfo Aricò, Leoncillo, Mario Nigro, Gastone Novelli and Pino Pascali. MP**

Valerio Adami's room, 1968  
Photo Ugo Mulas © Eredi Ugo Mulas  
Courtesy Archivio Ugo Mulas, Milano - Galleria Lia Rumma, Milano / Napoli

Rodolfo Aricò's room, 1968  
Photo Ugo Mulas © Eredi Ugo Mulas  
Courtesy Archivio Ugo Mulas, Milano - Galleria Lia Rumma, Milano / Napoli

Visitors at the the 34th International Art Exhibition, 1968  
Photo Ugo Mulas © Eredi Ugo Mulas  
Courtesy Archivio Ugo Mulas, Milano - Galleria Lia Rumma, Milano / Napoli

Declaration by Mario De Luigi, 1968  
Photo Ugo Mulas © Eredi Ugo Mulas  
Courtesy Archivio Ugo Mulas, Milano - Galleria Lia Rumma, Milano / Napoli

34th International Art Exhibition, 1968  
Photo Ugo Mulas © Eredi Ugo Mulas  
Courtesy Archivio Ugo Mulas, Milano - Galleria Lia Rumma, Milano / Napoli

Leoncillo in his room, 1968  
Photo Ugo Mulas © Eredi Ugo Mulas  
Courtesy Archivio Ugo Mulas, Milano - Galleria Lia Rumma, Milano / Napoli

Leoncillo's room, 1968  
Photo Ugo Mulas © Eredi Ugo Mulas  
Courtesy Archivio Ugo Mulas, Milano - Galleria Lia Rumma, Milano / Napoli

Mario Nigro in his room, 1968  
Photo Ugo Mulas © Eredi Ugo Mulas  
Courtesy Archivio Ugo Mulas, Milano - Galleria Lia Rumma, Milano / Napoli

Protests in front of the United States of America pavilion, 1968  
Photo Ugo Mulas © Eredi Ugo Mulas  
Courtesy Archivio Ugo Mulas, Milano - Galleria Lia Rumma, Milano / Napoli

Pino Pascali, 1968  
Photo Ugo Mulas © Eredi Ugo Mulas  
Courtesy Archivio Ugo Mulas, Milano - Galleria Lia Rumma, Milano / Napoli

Pino Pascali in his room, 1968  
Photo Ugo Mulas © Eredi Ugo Mulas  
Courtesy Archivio Ugo Mulas, Milano - Galleria Lia Rumma, Milano / Napoli

Declaration by Pino Pascali, 1968  
Photo Ugo Mulas © Eredi Ugo Mulas  
Courtesy Archivio Ugo Mulas, Milano - Galleria Lia Rumma, Milano / Napoli

Opening of the 34th International Art Exhibition, 1968  
Photo Ugo Mulas © Eredi Ugo Mulas  
Courtesy Archivio Ugo Mulas, Milano - Galleria Lia Rumma, Milano / Napoli

Giangiaco Spadari arrested by the police, 1968  
Photo Ugo Mulas © Eredi Ugo Mulas  
Courtesy Archivio Ugo Mulas, Milano - Galleria Lia Rumma, Milano / Napoli

Tommaso Trini arrested by the police, 1968  
Photo Ugo Mulas © Eredi Ugo Mulas  
Courtesy Archivio Ugo Mulas, Milano - Galleria Lia Rumma, Milano / Napoli

Giuseppe Ungaretti and Milena Milani among the young people who garrison San Marco, 1968  
Photo Ugo Mulas © Eredi Ugo Mulas  
Courtesy Archivio Ugo Mulas, Milano - Galleria Lia Rumma, Milano / Napoli

Emilio Vedova, 1968  
Photo Ugo Mulas © Eredi Ugo Mulas  
Courtesy Archivio Ugo Mulas, Milano - Galleria Lia Rumma, Milano / Napoli

David Lamelas's room, 1968  
Photo Ugo Mulas © Eredi Ugo Mulas  
Courtesy Archivio Ugo Mulas, Milano - Galleria Lia Rumma, Milano / Napoli

Belgian pavilion, 1968  
Photo Ugo Mulas © Eredi Ugo Mulas  
Courtesy Archivio Ugo Mulas, Milano - Galleria Lia Rumma, Milano / Napoli

Lydia Silvestri, 1968  
Photo Ugo Mulas © Eredi Ugo Mulas  
Courtesy Archivio Ugo Mulas, Milano - Galleria Lia Rumma, Milano / Napoli

Protest signs of the Accademia di Belle Arti's students, 1968  
Photo Ugo Mulas © Eredi Ugo Mulas  
Courtesy Archivio Ugo Mulas, Milano - Galleria Lia Rumma, Milano / Napoli

Luigi Nono, 1968  
Photo Ugo Mulas © Eredi Ugo Mulas  
Courtesy Archivio Ugo Mulas, Milano - Galleria Lia Rumma, Milano / Napoli

Gastone Novelli's canvases, 1968  
Photo Ugo Mulas © Eredi Ugo Mulas  
Courtesy Archivio Ugo Mulas, Milano - Galleria Lia Rumma, Milano / Napoli

Protests in Piazza San Marco, 1968  
Photo Ugo Mulas © Eredi Ugo Mulas  
Courtesy Archivio Ugo Mulas, Milano - Galleria Lia Rumma, Milano / Napoli

The police guards Piazza San Marco, 1968  
Photo Ugo Mulas © Eredi Ugo Mulas  
Courtesy Archivio Ugo Mulas, Milano - Galleria Lia Rumma, Milano / Napoli

Mario De Micheli, 1968  
Photo Ugo Mulas © Eredi Ugo Mulas  
Courtesy Archivio Ugo Mulas, Milano - Galleria Lia Rumma, Milano / Napoli

---

## 3.9 The protests as recorded by the Istituto Luce archives

*Tempi nostri. La mostra del Cinema contestata*  
Istituto Luce

*Contestazione di studenti e artisti all'inaugurazione della Biennale di Venezia,*  
Notizie Cinematografiche. Istituto Luce, 1968

---

## 3.10 The protest at the International Film Festival in 1968, seen through the Rai Teche and AAMOD archives

Materials from the archives of the Rai and AAMOD -  
Archivio audiovisivo del movimento operaio e democratico

TG news service – RAI, Carlo Mazzarella, 27 August 1968. RAI

TG news service – RAI, Carlo Mazzarella, 29 August 1968. RAI

TG news service – RAI, Carlo Mazzarella, 31 August 1968. RAI

TG news service – RAI, Carlo Mazzarella, 1 September 1968. RAI

TG news service – RAI, Carlo Mazzarella, 2 September 1968. RAI

Zavattini: protest at the Venice International Film Festival, 1968, Aamod

---

## 3.11 Photos of protests at the Lido during the Venice International Film Festival

**On 20 August 1968 Soviet tanks entered Prague. That same day, ANAC (the National Association of Filmmakers) announced that it would be boycotting the "Exhibition of the Powerful" in protest against La Biennale's Fascist-era statute, which dated back to 1938. Bernardo Bertolucci, Liliana Cavani and Pier Paolo Pasolini struggled to decide whether to show their movies anyway or withdraw them in solidarity with the protesters. In the meantime, some members of the jury – Henri Langlois, Jonas Mekas and Edgar Reitz – resigned. On 24 August the Palazzo del Cinema was cordoned off by the police and the gala evening was cancelled, with the exhibition opening only on 27 August. Marco Ferreri, Ugo Gregoretti, Citto Maselli, Gillo Pontecorvo, Pier Paolo Pasolini, Franco Solinas and Cesare Zavattini made speeches and a few scuffles broke out, with a makeshift bomb exploding but causing more media noise than actual damage. A counter-demonstration of Lido shopkeepers and hoteliers who wanted the festival to take place was announced. Luigi Chiarini, the festival director, allowed a protesters' assembly to be held in the Sala Grande, but at two o'clock in the morning their time was up and the police moved in to clear the hall. GG**

Protest at the XXIX Venice International Film Festival.  
Pier Paolo Pasolini, Lido 1968.  
Photo Archivio Cameraphoto Epoche / © Vittorio Pavan

Cesare Zavattini in Venice, 1968. Photo Cameraphoto

Protest at the XXIX Venice International Film Festival, 1968.  
Photo Studio Giacomelli

Marco Ferreri, 1968. Photo Gianni Berengo Gardin

Protest at the XXIX Venice International Film Festival, 1968. Photo Olympia

Protest in front of the Palazzo del Cinema, 1968.  
Photo Gianni Berengo Gardin

Pier Paolo Pasolini, 1968

Pier Paolo Pasolini, 1968  
Photo Studio Bernardi

Pier Paolo Pasolini, 1968  
Photo Fotoattualità

Pier Paolo Pasolini, 1968  
Photo Studio Giacomelli

Luigi Chiarini at the press conferenze, 1968. Photo Studio Bernardi

Public protest at the XXIX Venice International Film Festival, 1968.  
Photo Studio Giacomelli

Public protest at the XXIX Venice International Film Festival, 1968.  
Photo Fotoattualità

Public protest at the XXIX Venice International Film Festival, 1968.  
Photo Studio Ferruzzi

Alexander Kluge at the Award Ceremony, 1968

Carmelo Bene at the Award Ceremony, 1968. Photo Studio Bernardi

Alexander Kluge and Carmelo Bene at the Award Ceremony, 1968.  
Photo Studio Bernardi

Alexander Kluge at the Award Ceremony, 1968. Photo Studio Bernardi

Carmelo Bene and Lidia Mancinelli at the Award Ceremony, 1968.  
Photo Studio Giacomelli

## 3.12 The Giornate del Cinema Italiano, 1972

With the Venice Film Festival now in the hands of Gian Luigi Rondi and doubts still surrounding the proposed new statute (approved on 26 July 1973), the filmmakers' association, ANAC, decided to hold an alternative festival in Venice with Marco Bellocchio, Marco Ferreri, Nanni Loy, Citto Maselli, Giuliano Montaldo, Ugo Pirro, Ettore Scola and Cesare Zavattini taking part. The resulting Giornate del Cinema Italiano opened on 1 September 1972, with screenings that included Bellocchio's *Nel nome del padre*. Jean-Luc Godard arrived from France and took part in packed public debates, with Marcello Mastroianni, Gian Maria Volonté, Elio Petri and Francesco Rosi also present. Participants asserted the right to make films as an act of social participation that should not be subject to gatekeepers or prizes. In 1973 the Venice International Film Festival was not held and the Giornate del Cinema Italiano occupied the space that La Biennale still left vacant, despite new reforms. GG

Materials from the Archivio AAMOD -  
Archivio audiovisivo del movimento operaio e democratico, 1972

Giornate del cinema italiano, Jean-Luc-Godard, 1972.  
Photo Archivio Cameraphoto Epoche / © Vittorio Pavan

Giornate del cinema italiano, Campo S.Margherita, 1972.  
Photo Archivio Cameraphoto Epoche / © Vittorio Pavan

Giornate del cinema italiano, Florinda Bolkan, 1972.  
Photo Archivio Cameraphoto Epoche / © Vittorio Pavan

Giornate del cinema italiano, Laura Betty, 1972.  
Photo Archivio Cameraphoto Epoche / © Vittorio Pavan

Giornate del cinema italiano, Marcello Mastroianni, Marco Ferreri, 1972.  
Photo Archivio Cameraphoto Epoche / © Vittorio Pavan

Giornate del cinema italiano, Marco Bellocchio, 1972.  
Photo Archivio Cameraphoto Epoche / © Vittorio Pavan

Giornate del cinema italiano, Marco Ferreri, Nanni Loy, 1972.  
Photo Archivio Cameraphoto Epoche / © Vittorio Pavan

Giornate del cinema italiano, Marco Ferreri, 1972.  
Photo Archivio Cameraphoto Epoche / © Vittorio Pavan

Giornate del cinema italiano, Michelangelo Antonioni, Bernardo Bertolucci, 1972.  
Photo Archivio Cameraphoto Epoche / © Vittorio Pavan

Giornate del cinema italiano, Pier Paolo Pasolini, Ninetto Davoli, 1972.  
Photo Archivio Cameraphoto Epoche / © Vittorio Pavan

Giornate del cinema italiano, Tinto Brass, Gigi Proietti, 1972.  
Photo Archivio Cameraphoto Epoche / © Vittorio Pavan

Giornate del cinema italiano, Ugo Tognazzi, 1972.  
Photo Archivio Cameraphoto Epoche / © Vittorio Pavan

Giornate del cinema italiano, Gian Maria Volonté, 1972.  
Photo Archivio Cameraphoto Epoche / © Vittorio Pavan

## 3.13 Press clippings about the Biennale Cinema protests

Telegram from Pietro Germi to Umbro Apollonio and Wladimiro Dorigo, 1968

Comitato di coordinamento per il boicottaggio della Mostra Cinematografica flyer, 1968

*Perché contestiamo la Mostra di Venezia - Non è stata mai capace di camminare con il cinema*  
L'Unità, Roma, 2 August 1968, Ugo Casiraghi

*Pioggia di smentite sulle partecipazioni alla Mostra - Autori e studenti: a Venezia per lottare*  
Paese Sera, Roma, 12 August 1968

*Farà presto caldo in laguna: dopo la Biennale d'arte anche la Mostra cinematografica rischia di avere uno svolgimento avventuroso o addirittura di essere rinviata sine die*  
Il Giornale di Sicilia, Palermo, 9 August 1968, Gregorio Napoli

*La morte di Venezia è la vita per Cannes*  
La Notte, Milano, 8 August 1968, Mimi Pinson

*Perché contestiamo la Mostra di Venezia - E' più un'accademia che una palestra di cultura*  
L'Unità, Milano, 4 August 1968, Ugo Casiraghi

*Venezia 68. Sarà la mostra della violenza*  
ABC, August 1968, Callisto Cosulich

*Questo turbolento Festival di Venezia. Al cinema con l'elmetto*  
Giornale di Bergamo, 23 August 1968

*Per la Mostra si prevedono scontri al Consiglio comunale*  
L'Unità, Roma, 30 August 1968

*Buttati fuori dal Lido i contestatori comunisti*  
Il Secolo d'Italia, Roma, 28 August 1968

*Fino all'ultimo respiro il braccio di ferro fra Luigi Chiarini e i suoi molti nemici - C'è Foscarelli spara sul Lido, Marialivia Serini*

*Perché contestiamo la Mostra di Venezia - Selezione e giuria strumenti di una struttura antiquata*  
L'Unità, 8 August 1968, Ugo Casiraghi

*Pronta replica del direttore alla decisione di occupare la Mostra - Buffonate! dice Chiarini*  
La Notte, Milano, 21 August 1968, Ernesto Baldo

*Si preparano le misure per l'ordine - A Venezia Mostra col mitra*  
Paese Sera, Milano, 20 August 1968

*Mentre Chiarini annuncia il programma ufficiale - Adesso gli arrabbiati difendono Venezia*  
La Notte, Milano, 22 August 1968

*Venezia - Chiarini attende a piè fermo i contestatori*  
La Gazzetta del Mezzogiorno, 25 August 1968, Piero Virgintino

*Venezia '68 - La Mostra a una dimensione*  
Il Giornale d'Italia, 24-25 August 1968, Claudio Quarantotto

*Anche Bertolucci ritira il film ma annuncia le sue dimissioni dall'Anac*  
Il Tempo, 24 August 1968

*Il Leone sempre più contestato - Dimissioni alla Cinemostra*  
Oggi riuniti i registi: domani forse la Mostra  
Paese Sera, Roma, 26 August 1968

*Questa mostra - dicono non si farà - Pasolini ha ritirato il suo film*  
Il Giorno, 21 August 1968, Natalia Aspesi

*Molto rumore, pochissimi danni - Bomba carta contro la Mostra di Venezia*  
Giornale di Sicilia del Lunedì, Palermo, 19 August 1968, Aurelio Minazzi

*Il questore di Venezia tutelerà l'ordine - Una Mostra con poliziotti*  
Paese Sera, Milano, 17 August 1968

*Chiarini: la bomba non fermerà il festival*  
Corriere d'informazione, Milano, 19 August 1968, Giancarlo Bo

*Chiarini ha presentato il programma della imminente Mostra del Cinema di Venezia - il Leone ha ruggito*  
Il Giornale di Sicilia, Palermo, 23 August 1968, Gregorio Napoli

*Chiarini: non mi spaventano i pomodori*  
Tempo, Milano, 20 August 1968, Enrico Nassi

*Chiarini parlamenta con i contestanti*  
Venezia Notte, Venezia, 8 August 1968, Giorgio Soligo

*Ci contestino pure tutto - E' una mostra che dà il meglio*  
Il Giorno, Milano, 11 August 1968, Vittorio Cossato

*Come si comporterà Luigi Chiarini durante la Mostra se ci saranno disordini o incidenti? La Polizia non la chiamano!*  
Giornale di Sicilia, 17 August 1968

*Chiarini a Renoir: Ti prego aiutami!*  
Momento sera, 25 August 1968, Maurizio Liverani

*Si apre domani al Lido il Festival della contestazione - Ci sarà o no la guerra per la Mostra di Venezia?*  
Stampa Sera, 24 August 1968, Carlo Moriondo

*Movimentata antivedigialità della Mostra del Cinema, Chiarini attacca a fondo i contestatori di Venezia*  
Stampa Sera, 24 August 1968

*Polemico e brillante - Chiarini con i contestatori*  
La Notte (di Venezia), 23 August 1968



Chiarini: *contesto da 6 anni la Mostra di Venezia ma sono deciso a respingere ogni sopraffazione*  
La Voce Adriatica, Ancona, 17 August 1968

I contestatori coperti da lividi al dibattito promosso da Chiarini  
La Stampa, Torino, 29 August 1968, Gigi Ghirotti

I registi occuperanno il Palazzo del Cinema -  
Dietrofront di Pasolini che ritira il suo film  
Il Piccolo, Trieste, 21 August 1968

Il Padrone del Lido - Nonostante i ritiri e le polemiche  
Chiarini condurrà in porto il festival del cinema di Venezia  
La Fiera letteraria, 15 August 1968, Carlo Della Corte

Pasolini: *Roma vuol chiudere la Mostra perché non accetta la autogestione*  
Gazzetta del Sud, Messina, 27 August 1968

Ancora abusi a puntello della baracca della Mostra  
L'Unità, Roma, 5 September 1968, Aggeo Savioli

Venezia: *cronaca dall'antifestival - I contestatori minacciano: attenti, qui ci scappa il morto*  
Gente, 4 September 1968, Ornella Ripa

Non si è aperta regolarmente la XXIX Mostra - Il Leone miagola  
Avanti!, 27 August 1968, Lino Micciché

I registi occuperanno il palazzo della Mostra  
Paese Sera, Milano, 21 August 1968

Si fa, non si fa? La Mostra di Venezia in mare aperto  
Gazzetta del Mezzogiorno, 27 August 1968

I rivoluzionari decisi a far saltare in aria la Mostra  
Stampa Sera, Torino, 21 August 1968, Gianni Ghirardini

È una bella babilonia, la Mostra della contestazione  
Il Giorno, Milano, 22 August 1968, Natalia Aspesi

L'Anac per l'occupazione - Gli studenti saranno neutrali  
Momento Sera, Roma, 22 August 1968, Piero Zanotto

Verso una co-gestione la mostra di Venezia? - La manifestazione sembra naufragata  
Il Giornale di Pavia, 27 August 1968

La calda Mostra di Venezia - Mancano sette giorni - Cosa avverrà?  
Momento Sera, Roma, 17 August 1968

Pasolini ritira Teorema da Venezia  
La Sicilia, 21 August 1968

Il Leone contestato - Mostra in tempesta  
Paese Sera, Milano, 27 July 1968

Il regista cederebbe alle insistenze del produttore del suo film  
e non si opporrebbe alla presentazione di Teorema - Pasolini possibilista?  
Il Giornale di Sicilia, Palermo, 22 August 1968, Gregorio Napoli

Il Festival in gondola tra proteste smentite e soprattutto gran caos  
L'Eco di Bergamo, 27 August 1968

Una bomba carta è stata fatta esplodere da fantomatici anarchici-contestanti,  
Mini - attentato alla Mostra  
Venezia Notte, Venezia, 19 August 1968

La nostra inchiesta sul Leone contestato - Una Comune del cinema libero  
Paese Sera, 29 July 1968

Apriamo un'inchiesta sul Leone contestato - Vogliono libertà e un cinema di idee  
Paese Sera, Roma, 25 July 1968, Mario Balvetti

Carmelo Bene: *Io difendo Chiarini*  
Momento Sera, 5-6 August 1968, Antonio Troisio

Anche Antonioni e i Centri Universitari schierati contro la Mostra veneziana  
L'Unità, Roma, 14 August 1968

La Biennale ribadisce: la Mostra si farà. D'accordo la maggioranza degli autori  
L'Italia - Milano, 24 August 1968

Antonioni: *no alla mostra*  
Paese Sera, Milano, 14 August 1968

Marcuse: *che cos'è la Mostra del Cinema?*  
La Notte - Milano, 14 August 1968, Bruno Tosi

Sempre più agitate le acque del Festival  
L'Avvenire d'Italia, Bologna, 22 August 1968, Piero Zanotto

Disagio a Venezia  
Paese Sera, Roma, 22 August 1968

Contrastanti giudizi sulla Mostra di Rossellini, Visconti e Antonioni  
Corriere di Napoli, 14 August 1968, Paolo Perrone

Film d'arte e stato poliziesco  
Paese Sera, Milano, 3 August 1968

Per Chiarini conto alla rovescia  
La Fiera letteraria, Roma, 29 August 1968, Carlo della Corte

Bellocchio il duro marcia giù su Venezia  
Gazzetta del Sud, Messina, 24 August 1968, Sergio Ascanio

Sartre sulla Mostra di Venezia  
Paese Sera, 21 August 1968

I registi francesi: *siamo contro la Mostra*  
Paese Sera, 23 August 1968

I contestatori in Consiglio Comunale (ma l'o.d.g. relativo è stato rinviato)  
La Notte, 3 September 1968, Giampiero Rizzon

Rossellini favorevole Antonioni contrario alla Mostra di Venezia  
La Sicilia, 14 August 1968

Impedire le proiezioni a Venezia è come bruciare i libri nelle piazze  
Il Piccolo, 24 August 1968

Si prepara il sabotaggio organizzato della Mostra del Cinema a Venezia  
Il Giornale d'Italia, 7-8 August 1968

Fermo no a Venezia del CUC e di Antonioni  
L'Unità Roma, 14 August 1968

Cinema: *no degli studenti*  
Paese Sera, 23 July 1968

Bandita la logica a Venezia  
Corriere della Sera, Milano, 24 August 1968, Sandro Meccoli

---

## 3.14 Protests at the presentation of *Chung Kuo, Cina* by Michelangelo Antonioni

The screening of Michelangelo Antonioni's *Chung Kuo, Cina* at the Biennale Cinema 1974 caused a commotion.

As Umberto Eco wrote: "Ripa di Meana was inside the circle of wagons. And galloping around outside it were the Chinese government, the Italian foreign minister, the Italian ambassador in Beijing, the Italian-Chinese friendship association, the police, the fire brigade and certain pro-China lone wolves. Everyone knows how it went. China protested against the imminent screening of the film at La Fenice, the Italian government did everything possible to block it, the Biennale resisted in the name of freedom of information and artistic expression. At the last minute the Venice prefect came to the aid of the Beijing regime and suddenly discovered that La Fenice was unfit for use as a cinema (after films had been screened there non-stop for a week). Meana got on the phone to his assistants and, in the space of half an hour, had Cinema Olimpia freed up for the screening". Outside the theatre, police held back demonstrators who wanted to prevent the film from being shown, claiming that it denigrated Maoist China. GG

*Chung Kuo - Cina* by Michelangelo Antonioni, 1974

The protest of the pro-Maoists outside the Cinema Olimpia in Venice for the screening of *Chung Kuo - Cina* by Michelangelo Antonioni, 1974

Giacomo Gambetti, Michelangelo Antonioni and Carlo Ripa di Meana at the press conference for *Chung Kuo- Cina*, 1974

Wladimiro Dorigo, Michelangelo Antonioni and Umberto Eco at the press conference for *Chung Kuo- Cina*, 1974

---

## 3.15 American dance in Venice in 1968: Alvin Ailey, Alwin Nikolais and Merce Cunningham

At the dawn of the youth protests which were to rock the whole world in the late 1960s, Venice was showcasing American dance. In 1967 Alvin Ailey (1931-1989) caused quite a stir with *Blues Suite, Prodigal Prince and Revelations*, presented at La Biennale's International Festival of Contemporary Music. Ailey drew on African American music and traditions to create a peculiar form of modern dance, refusing to reduce its black dancers to the stereotypes of figures mostly employed to entertain a white audience. Avoiding the snare of picturesque or stylised "ethnic" dance, Ailey's choreographies stood out for their scenic composition and original content, in a new, proudly independent vision that was free of the European American straitjacket. Ailey's shows were on their third European tour by the time they got to Venice in 1967,

but their critical reception in Italy was nonetheless mixed, with admiration for their linguistic and stylistic innovations but perplexity over the inclusion of unusual American modern dance performances at the International Festival of Contemporary Music.

In 1968, Alwin Nikolais (1910-1993), an American of Russian-German descent, ushered in an essentially abstract, formal, non-narrative kind of dance in his emblematic *Imago*, a world away not only from the illustrations of music traditional in the West, but also from the expressive mould of modern European dance. As a standard bearer of cutting-edge experimentation, who personally oversaw the movements, music, lights and costumes of his works, Nikolais was the definition of a total artist. Californian dancer, choreographer and teacher Carolyn Carlson, who later headed Teatro Danza La Fenice (1980-1985) and managed the Biennale Danza Department from 1999 to 2002, was part of the cast. EGV

Merce Cunningham (1919-2009), a choreographer from a progressive European American background, had been a dancer for Martha Graham (1894-1991) and was the partner of musician John Cage (1912-1992). He made dance independent as a mobile, formal, plotless set of signs, based on elements of chance, coexisting with yet unfettered from the music and the objects on stage. In Piazza San Marco in 1972 he staged one of his most remarkable *Events*: after his dancers used brooms to clear out a space at the centre of the crowd, they performed amidst sound-emitting chairs in a dynamic of pure movement, on the bare paving stones of a space imbued with history. EGV

Alvin Ailey American Dance Theater's manifesto, Teatro La Fenice, Alvin Ailey, 1967

*Alvin Ailey Dance Theater* from the 30th International Festival of Contemporary Music catalogue, 1967

Alvin Ailey American Dance Theater: *Blues suite, Prodigal prince, Revelations*, Alvin Ailey, 1967. Photo Studio Giacomelli

Alvin Ailey American Dance Theater: *Blues suite, Prodigal prince, Revelations*, Alvin Ailey, 1967. Photo Studio Ferruzzi

Alvin Ailey American Dance Theater: *Blues suite, Prodigal prince, Revelations*, Alvin Ailey, 1967. Photo Reporter Servizi Fotografici

*Balletti negri e indiani non convincono a Venezia*  
Il Popolo, 14 September 1967

*L'Alvin Ailey Dance Theater successo dell'armonia e dell'invenzione*,  
Il Popolo, 14 September 1967

Poster for the Alwin Nikolais Dance Company's Ballets,  
*Imago (the city curious)*, Teatro La Fenice, Alwin Nikolais, 1968

Alwin Nikolais Dance Company's Ballets, *Imago (the city curious)*,  
Teatro La Fenice, Alwin Nikolais, 1968. Photo Studio Ferruzzi

Alwin Nikolais Dance Company's Ballets, *Imago (the city curious)*,  
Teatro La Fenice, Alwin Nikolais, 1968. Photo Reporter Servizi Fotografici

Alwin Nikolais Dance Company's Ballets, *Imago (the city curious)*,  
Teatro La Fenice, Alwin Nikolais, 1968. Photo Studio Giacomelli

Alwin Nikolais Dance Company's Ballets, *Imago (the city curious)*,  
Teatro La Fenice, Alwin Nikolais, 1968. Photo Robert Sosenko

The Alvin Nikolais American Dance Company program No. 1, 1968

Nikolais Dance Co. Stage dressing and lighting requirements, 1968

*Preziose miniature di Castiglioni e Bussotti*  
L'Unità, 16 September 1968, Rubens Tedeschi

*Sotto i camicioni i pepli di Isadora*  
La Notte, 14 September 1968, Luigi Rossi

Merce Cunningham & Dance Company's poster: *Canfield*, 1972

Merce Cunningham & Dance Company: *Canfield*, Merce Cunningham, 1972.

Merce Cunningham & Dance Company: *Canfield*, Merce Cunningham, 1972.  
Photo Studio Ferruzzi

Merce Cunningham & Dance Company's poster: *Rainforest*,  
*Winterbranch*, TV Rerun, 1972

Merce Cunningham & Dance Company: *Rainforest*, *Winterbranch*, TV Rerun,  
Merce Cunningham, 1972. Photo Studio Ferruzzi

Merce Cunningham & Dance Company's poster:  
*Piazza San Marco Event*, 1972

Merce Cunningham & Dance Company: *Piazza San Marco Event*,  
Merce Cunningham, 1972. Photo Reporter Servizi Fotografici

Merce Cunningham & Dance Company: *Piazza San Marco Event*,  
Merce Cunningham, 1972. Photo Studio Ferruzzi

*Sposa la danza allo scenario di piazza S. Marco*  
Il Giorno, 15 September 1972, Lorenzo Arruga

*Danza in piazza a suon di campane*  
Paese sera, 17 September 1972, Vittoria Ottolenghi

## 3.16 Simone Forti

Born in Florence in 1935, Simone Forti took refuge in the United States with her family after Italy issued anti-Semitic laws in 1938. A choreographer, dancer and writer, she began experimenting with the language of movement and the possibilities of improvisation in the early 1950s. Forti's oeuvre is rooted in the work of Anna Halprin, who was responsible for the spread of postmodern dance in America, and of New York's Judson Dance Theatre, a varied group of experimental dancers and performers. Her choreographies were based on minimalist movement with improvisation and chance becoming an integral part of the end result.

It was in the very city of her birth – thanks to the *art-tapes* initiative, a series of videos produced by Maria Gloria Bicchieri – that the *No Title* performance was recorded in 1973. Known as *art/tapes/22*, this production included works by Marina Abramović, Vito Acconci, Allan Kaprow, Ketty La Rocca, Urs Lüthi, Dennis Oppenheim and Bill Viola, amongst others, which were subsequently acquired by La Biennale. MP

Video *Untitled*, performance by Simone Forti, 1972

# ROOM 4

## THE 1970S: INTERDISCIPLINARY AND POLITICAL WORK

In the early 1970s La Biennale's biggest problem was still its statute. Debates at the governmental level on the issue began in early 1973, and on 26 July the Italian Parliament finally approved new regulations to modernise the former Fascist statute, in force since 1938. It was not until 20 March 1974, however, that the board's eighteen members were appointed from across the political spectrum, carving up La Biennale between the parties. Carlo Ripa di Meana (Socialist Party) was elected president while Floris Ammannati (Christian Democracy), the former superintendent of Teatro La Fenice, was appointed secretary general. Vittorio Gregotti (Communist Party) took over the Visual Arts and Architecture departments, Giacomo Gambetti (Christian Democracy) was given Cinema and Television, and Luca Ronconi (Communist Party) was to head Theatre and Music. The new statute, in addition to adding Architecture and Television as new departments, highlighted the need for "ongoing activities" and "local activities". La Biennale thus emerged from the Giardini and theatres and moved out into uncharted terrain. Performances were presented at the Porto Marghera petrochemical plant, with an *Othello* remembered for its quality but also the uniqueness of the experience. Fabio Mauri directed the Ca' Foscari company in the provocatively titled *What is Fascism?*, which moved from a marquee in Campo San Polo to the rooms of a technical institute in Mestre and the Jesolo public library. The Living Theatre occupied town squares and unusual spaces, as did Jerzy Grotowski, with his workshop and performances on the island of San Giacomo in Paludo. In the meantime the old Giardini pavilions served as rehearsal spaces for the Accademia Internazionale di Danza. The Biennale Arte preserved its multiple exhibition format, with a range of events entrusted to various curators; disciplines were often mingled, as in the Molino Stucky project, which brought together art, architecture and city planning. 1974 was a year of great political and social tensions in Italy, with the Piazza della Loggia bombing in Brescia in May and the Italicus Express bombing in August. *La Biennale per una cultura democratica e antifascista* (La Biennale for

Democratic, Anti-Fascist Culture) was the overall title of the Venetian festivals that year, which tried to speak out powerfully against the reign of terror, dedicating the entire edition to Chile. The Biennale's 1975 calendar opened on 1 May and closed on 20 December after 220 days of exhibitions and activities, a vast number compared to the previous year. La Biennale flowed out of the Giardini and across the city, with the municipal government's assistance, into former shipyards on Giudecca, the church of San Lorenzo, and the Magazzini del Sale. Even other towns in the province were involved: Chioggia, Mira and Jesolo, as well as Mestre and Marghera. At the 1976 Biennale Arte, directed by Gregotti, the Central Pavilion focused on Spain in the year after Franco's death; 1977 explored the theme of "dissent". Then in 1978, the Biennale Arte adopted a deliberately non-political title: *Dalla natura all'arte dall'arte alla natura* (From Nature to Art and from Art to Nature). VP

# ROOM 4

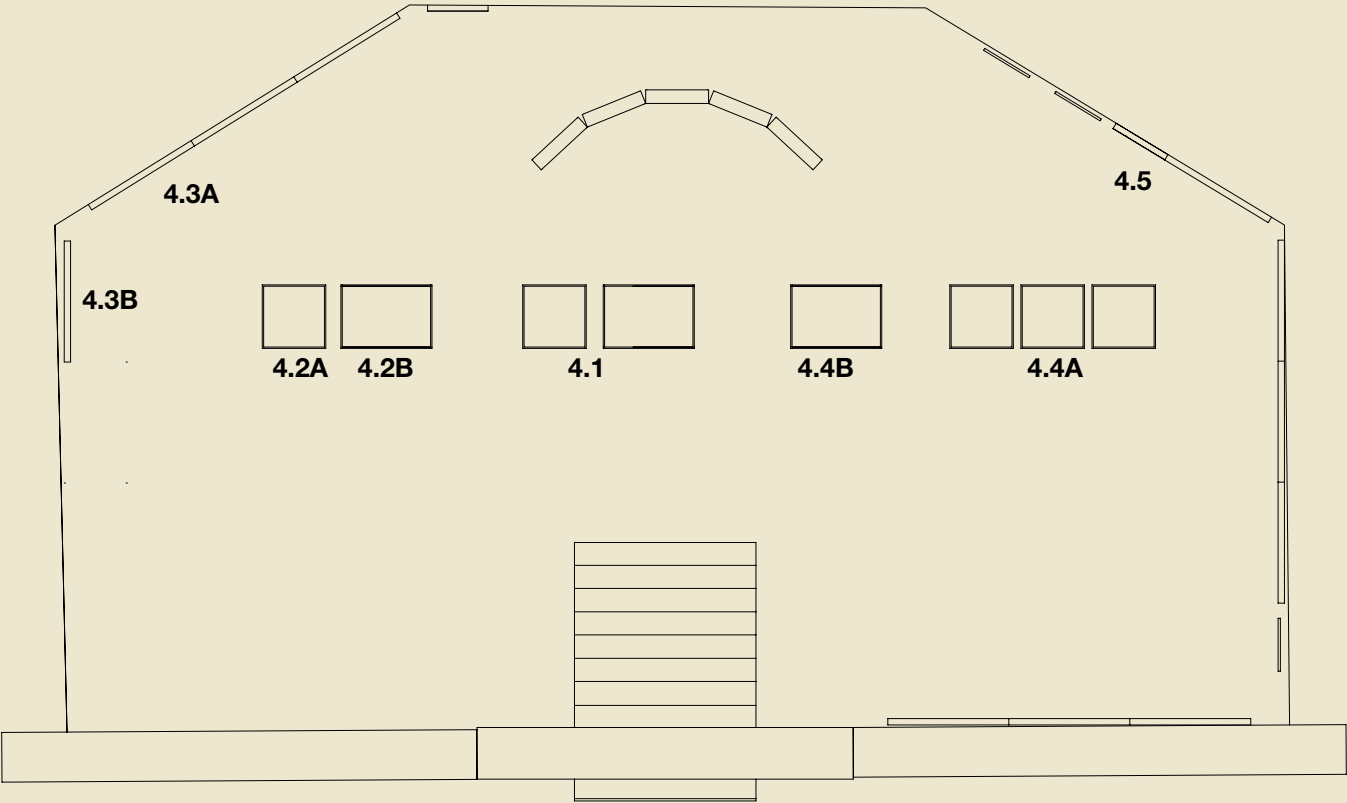

## 4.1 A new president and the Ca' Corner della Regina archive

1975 opened with a decidedly new outlook for La Biennale di Venezia: the statute had been approved, and the expanded board had appointed the department directors. In the second year of this new Biennale, the new president, Ripa di Meana, rebranded it “an international workshop”. The organisation’s board of directors was considering buying Ca’ Corner della Regina, a palazzo on the Grand Canal belonging to the Cassa di Risparmio di Venezia bank, as a site for the Biennale’s archives, which since 1973 had been managed by Wladimiro Dorigo. Dorigo was extremely adamant about the new role the Biennale had taken on in 1973, especially the “ongoing activities” that could revolve around the new archive site, which he himself rechristened ASAC: Archivio Storico delle Arti Contemporanee (Historical Archives of Contemporary Arts). Dorigo’s plan was to make Ca’ Corner della Regina a cultural centre, a library specialised in the contemporary arts with multimedia facilities, screening rooms, exhibitions and archives. It was decided from the outset that the archive should be computerised, and research into the history of La Biennale was undertaken for studies that would appear in its new journal, *Annuari*. ASAC opened in June 1976 and Carlo Ripa di Meana commented in an interview: “The creation of the archive, for example, would not have been possible without Dorigo’s expertise, as he managed to come up with a formula which convinced everyone to spend a great deal of money on this major initiative. The archive will also be used for exhibitions, it will be La Biennale’s museum. Film and graphic design exhibitions and debates are to be held there. It will be its own little Biennale, making use of material that already exists. It is a very ambitious attempt, and a very expensive one, but if it succeeds, it will be a huge thing, really huge.” VP

1 Spain *Avanguardia artistica e realtà sociale (1936 – 1976)*, opening, 1976. Photo Mark E. Smith

2, 10-13 Cà Corner della Regina, Archivio Storico delle Arti Contemporanee’s venue, 1976

3 Four-year general plan of activities and events (1974 – 1977) with an introduction by Carlo Ripa di Meana

4 *Annuario 1975. Eventi del 1974* curated by the Archivio Storico delle Arti Contemporanee

5 *Annuario 1976. Eventi del 1975* curated by the Archivio Storico delle Arti Contemporanee

6 *Annuario 1978. Eventi del 1976 - 1977* curated by Archivio Storico delle Arti Contemporanee

7 *Annuario 1979. Eventi del 1978* curated by the Archivio Storico delle Arti Contemporanee

8 *Archivio Storico delle Arti Contemporanee* leaflet, 1978

9 Carlo Ripa di Meana before Cà Corner della Regina, 1976. Photo Cameraphoto

14, 15 *Cos’è il fascismo*, by Fabio Mauri, Catalogue, 1974. Photo Lorenzo Capellini

16 *Cos’è il fascismo*, Fabio Mauri, Catalogue, 1974

17 *Cassio governa a Cipro*, Giorgio Manganelli, Catalogue, 1974 from *Othello* by William Shakespeare

18 Nicoletta Rizzi and Luca Ronconi during the rehearsals of *Cassio governa a Cipro*, by Giorgio Manganelli, 1974

19 Audience, *Cassio governa a Cipro*, by Giorgio Manganelli, 1974

## 4.2A *The Bachelor Machines*, curated by Harald Szeemann, 1975

*Junggesellenmaschinen / Les machines célibataires / Le macchine celibi* (The Bachelor Machines) was the title of a travelling exhibition organised by Harald Szeemann that ran from 5 July 1975 to 17 August at the Kunsthalle in Bern and then from 6 September to 4 November at the Magazzini del Sale. The title was inspired by a work by Marcel Duchamp now known as *Le Grand Verre* (The Large Glass) but originally called *La mariée mise à nu par ses célibataires, même* (The Bride Stripped Bare by Her Bachelors, Even), which dates to 1915-1923 (now in the Philadelphia Museum of Art). As the curator wrote, it is a work that “can be read on multiple levels: as a closed circuit and as the influence of an upper zone – that of the bride and the inscription – upon a lower zone – that of the bachelors”. The exhibition’s leitmotifs were the myth of the machine’s self-determination and the technological interpretation of love and sex. The exhibition featured a series of dynamic sculptures characterised by illogical, non-sequential movements, typical of the twentieth-century avant-gardes. These machines are “bachelors” because they produce nothing useful and merely waste energy, a veiled criticism of industrial mechanisms. Harald Szeemann (1933-2005) was a Swiss art historian who studied in Bern and Paris. In the 1960s he became curator of the Bern Kunsthalle, where he organised memorable exhibitions such as *When Attitudes Become Form* (1969). This event highlighted, for the first time, the importance of the artistic choices made by a curator: a figure who, through Szeemann’s work, became a bearer of new messages. In 1972 Szeemann, at that point an independent curator, directed Documenta 5 in Kassel. VP

1 Appointment letter from Carlo Ripa di Meana to Harald Szeemann, 6 March 1975

2 *Macchine per fare l’amore*, 1975, in *The Bachelor Machines*. Photo Cameraphoto

3 Telegram from Carlo Ripa di Meana to Vittorio Gregotti, 6 September 1975

4 *Il diamante*, Jacques Carelman, 1975, in *The Bachelor Machines*. Photo Mark E. Smith

5 *Il robot Anatol*, 1975, in *The Bachelor Machines*. Photo Cameraphoto

6 *The Bachelor Machines* exhibition catalogue, 1975

7 The machine of *Nella colonia penale* by Franz Kafka, 1975, in *The Bachelor Machines*. Photo Antonio Martinelli

8 James Lee Byars, 1975, in *The Bachelor Machines*. Photo Cameraphoto

9 Text by Harald Szeemann for *The Bachelor Machines*, 1975

## 4.2B *Ambiente/arte (Environment/Art), curated by Germano Celant, 1976*

Curated by Germano Celant, this exhibition was housed in the right wing of the Central Pavilion in 1976; the installation was designed by architect Gino Valle, and the theme was art's interaction with three-dimensional space. It started off by looking at the early avant-garde movements (Futurism, Constructivism, Dadaism), continuing through abstract experimentation, Lucio Fontana's spatial environments, and the performance work of Yves Klein, also featured in the exhibition poster. The final part was left to contemporary artists such as Carla Accardi, Gianni Colombo, Christo, Michelangelo Pistoletto and Andy Warhol. Celant's first step in organising the exhibition was a radical one – stripping down the history-filled Central Pavilion to its original state, its bricks and mortar, to create neutral spaces which were then filled up with a range of artworks and installations. Celant's show was a “novel and spectacular exhibition designed to immerse the Biennale's visitors in an all-encompassing, participatory experience.” In 1975 when Gregotti called Germano Celant to offer him this exhibition project, the latter was spending much of his time in Los Angeles, where he frequented the Light & Spaces artists. In previous years, in Italy, he had been the theorist of the Arte Povera movement which brought Italian artists such as Alighiero Boetti, Luciano Fabro, Jannis Kounellis, Mario Merz and Giulio Paolini into the international limelight. VP

- 1 Catalogue of the *Ambiente/Arte. Dal Futurismo alla Body Art* exhibition, 1976
- 2 Germano Celant and Jannis Kounellis at the *Ambiente/Arte* exhibition, 1976. Photo Cameraphoto
- 3 *Cavalli*, Jannis Kounellis, 1976 in *Ambiente/Arte*. Photo Cameraphoto
- 4 Letter from Germano Celant to Carlo Ripa di Meana, 28 October 1975
- 5 Letter from Germano Celant to Vittorio Gregotti, 22 February 1976
- 6 *Tornano in stalla i cavalli... d'arte*  
La notte, 23 July 1976
- 7 *Via i cavalli dalla Biennale dopo la protesta degli zoofili*  
Il Gazzettino, 23 July 1976
- 8 Report *Arte in / come Ambiente* by Germano Celant, 24 January 1976
- 9 Bettino Craxi visits with Carlo Ripa di Meana the *environment* by Mario Merz in the *Ambiente/Arte* exhibition, 1976. Photo Cameraphoto
- 10 Giorgio Napolitano visits the *environment* by Vito Acconci in the *Ambiente/Arte* exhibition, 1976. Photo Cameraphoto
- 11 Tina Anselmi visits with Carlo Ripa di Meana the *environment* by Sol Lewitt in the *Ambiente/Arte* exhibition, 1976. Photo Cameraphoto
- 12 Giulio Andreotti visits with Carlo Ripa di Meana and Vittorio Gregotti the *environment* by Sol Lewitt in the *Ambiente/Arte* exhibition, 1976. Photo Cameraphoto

## 4.3A *Concepts for the Mulino Stucky, curated by Vittorio Gregotti, 1975*

*Concepts for the Mulino Stucky* was the second Visual Arts and Architecture department initiative held at the Magazzini del Sale on the Zattere in 1975, after Harald Szeemann's *The Bachelor Machines*. Gregotti believed that the Biennale should not only present surveys of recent artistic tendencies, but explore new areas closely tied to the social context, bringing together disciplines such as art, architecture, photography, design and city

planning. *Concepts for the Mulino Stucky* was meant to shine a spotlight on the ruinous state of the imposing late nineteenth-century mill which looms over the island of Giudecca. The curator invited a group of artists and architects to examine this case study and take part in a competition for redevelopment proposals. The work presented in the exhibition mainly focused on conceptual and performative languages and Neo-Dada. The figures exhibiting at the Magazzini del Sale included Christian Boltanski, Gianni Colombo, Mark di Suvero, Luciano Fabro, Mario Merz, Annette Messager, Nam June Paik, Giulio Paolini, SITE (James Wines, Alison Sky, Emilio Sousa, Michelle Stone), Daniel Spoerri and Jean Tinguely. Happenings were also given space at the exhibition, with Janis Kounellis, for example, taking part from a boat moored behind the island. Mario Ceroli and Gianfranco Fini, on the other hand, built a large wooden crate in Piazza San Marco bearing the names of all the artists invited to the exhibition. This huge structure was transported by boat to the Giudecca shipyards and set on fire, and the charred remains were then placed in the Magazzini del Sale. VP

### Panel

- Poster of the *Concepts for the Mulino Stucky* exhibition. Ceroli Fini, 1975. S.Galante, Alessandro Zen
- 1 Aerial view of the Giudecca, 1975
  - 2 View of the Molino Stucky from the Zattere, 1975
  - 3 Exterior of the Molino Stucky, 1975. Photo Marco Balzarotti
  - 4, 5 Interior of the Molino Stucky, 1975. Photo Marco Balzarotti
  - 6 Interior of the Molino Stucky, 1975
  - 7 Poster of the *Concepts for the Mulino Stucky* exhibition, 1975
  - 8 Carlo Ripa di Meana, Vittorio Gregotti, Luca Ronconi, Giacomo Gambetti at the opening of the *Concepts for the Mulino Stucky* exhibition, 1975. Photo Lorenzo Capellini
  - 9 Project by Mario Ceroli and Gianfranco Fini for *Concepts for the Mulino Stucky*, 1975. Photo Studio Giacomelli
  - 10 Giulio Paolini during the preparation of the *Concepts for the Mulino Stucky* exhibition, 1975. Photo Lorenzo Capellini
  - 11 Vittorio Gregotti observes the installation *Platea*, Giulio Paolini, 1975. Photo Lorenzo Capellini
  - 12 Vittorio Gregotti during the preparation of the artwork *Contentitore per le Proposte per il Mulino Stucky*, by Mario Ceroli and Gianfranco Fini, Piazza San Marco, 1975. Photo Lorenzo Capellini
  - 13 Jannis Kounellis at the Giudecca, 1975. Photo Lorenzo Capellini
  - 14 Jannis Kounellis's portrait before the Molino Stucky, 1975. Photo Lorenzo Capellini
  - 15 Mario Ceroli burns the *Contentitore per le Proposte per il Mulino Stucky*, 1975. Photo Lorenzo Capellini
  - 16 Guy de Rougemont's portrait, 1975. Photo Studio Giacomelli
  - 17-19 Postcard of the *Concepts for the Mulino Stucky* exhibition, by Errò, 1975
  - 20 Staging of the artwork *Per Allende* by Mark di Suvero in the *Concepts for the Mulino Stucky* exhibition, 1975. Photo Mark E. Smith
  - 21 *Itinéraires prévus pour la permutation de St. Marc, Palais des Doges et Moulin Stucky*, by Guy de Rougemont, 1975. Photo Mark E. Smith
  - 22 Project by Errò for the *Concepts for the Mulino Stucky* exhibition, 1975
  - 23 *Per Allende*, Mark di Suvero, 1975. Photo Studio Giacomelli
  - 24 Gustav Peichl and Vittorio Gregotti, 1975. Photo Lorenzo Capellini
  - 25 Vittorio Gregotti during the preparation of the artwork *Contentitore per le Proposte per il Mulino Stucky*, by Mario Ceroli and Gianfranco Fini, Piazza San Marco, 1975. Photo Lorenzo Capellini
  - 26 Vittorio Gregotti with Mario Ceroli and Gianfranco Fini inside the *Contentitore per le Proposte per il Mulino Stucky*, 1975. Photo Lorenzo Capellini

- 27 Bernhard Luginbuhl carries the materials for his artwork, 1975. Photo Lorenzo Capellini
- 28, 30 Piotr Kowalski's portrait, 1975. Photo Lorenzo Capellini
- 29 Nam June Paik's portrait, 1975. Photo Lorenzo Capellini
- 31, 40 Audience at the opening of the *Concepts for the Mulino Stucky* exhibition, Magazzini del Sale, 1975
- 32 *Pronto soccorso*  
Il Corriere della sera, 21 September 1975, Tommaso Trini
- 33 *La Biennale de Venice livree aux croque-morts*  
Le Figaro, 17 October 1975
- 34 *Biennale contestata*  
Il Gazzettino, 18 October 1975
- 35 *La Biennale si difende*  
La Voce Repubblicana, 7 September 1975
- 36 *Progetti per distruggere il Mulino da Salvare*  
Il Corriere della Sera, 21 September 1975
- 37 Opening of the *Concepts for the Mulino Stucky* exhibition, Magazzini del Sale, 1975. Photo Lorenzo Capellini
- 38 Audience at the opening of the *Concepts for the Mulino Stucky* exhibition, Magazzini del Sale, 1975. Photo Lorenzo Capellini
- 39 Audience at the opening of the *Concepts for the Mulino Stucky* exhibition, Magazzini del Sale, 1975. Photo Mark E. Smith
- 41 *Il Mulino del popolo*  
Nord est, 16 October 1975
- 42 Opening of the *Concepts for the Mulino Stucky* exhibition, Magazzini del Sale, 1975
- 43 *Intervento di feedback*, Environmedia, 1975. Photo Francesco Petit
- 44 *4 giorni di seminario aperto sull'uso e sulla lettura della comunicazione audiovisiva*, brochure, 1975
- 45 *Comunicazione comunitaria: l'esperienza di comunicazione audiovisiva nel quartiere della Giudecca*, catalogue, 1975

### 4.3B Rationalism and Italian Architecture in the Fascist Period, 1919-42, 1976

In 1976 architecture became La Biennale's new sphere of experimentation. This department, called "Visual Arts and Architecture", was directed by Vittorio Gregotti, who called on Silvia Danesi and Luca Patetta to curate *Il Razionalismo e l'Architettura in Italia tra le due guerre 1919-1942* (Rationalism and Italian Architecture in the Fascist Period, 1919-42). Presented in the deconsecrated church of San Lorenzo, the exhibition focused on architectural design and its relationship with political power. Around 400 pieces of preparatory material were shown – sketches, perspective drawings, technical drawings, models – documenting the design phase. It was divided up into two parts. The first dealt with the decade from 1920 to 1930 and centred on Milan, Turin and Rome. The second highlighted the Fascist regime's interference in architectural culture and the two approaches which resulted from this: one that accommodated government policy, the other that opposed Fascism. The material was organised around the theme of housing, a fundamental one for European Rationalism, major national competitions, historic centres, public building projects and work promoted by the regime. It documented demolitions in Italy's historic town centres which led to the destruction of whole neighbourhoods, with real estate speculation and the conversion of residential areas into business districts. These two sections were linked by an area documenting the work of the Movimento Italiano per l'Architettura Razionale (MIAR). This movement held exhibitions of Rationalist architecture in Rome in 1928 and 1931, with a decisive role being played

by the "Gruppo 7": Luigi Figini, Guido Frette, Sebastiano Larco, Adalberto Libera, Gino Pollini, Carlo Enrico Rava and Giuseppe Terragni. MCC

- 1 *Ambiente, partecipazione, strutture culturali* leaflet, 1976
- 2 Vittorio Gregotti, Harald Szeemann and Ingeborg Lüscher, 1976  
Photo Cameraphoto
- 3 Carlo Ripa di Meana during the opening of the exhibition, 1976  
Photo Cameraphoto
- 4 Exterior of the former Saint Lorenzo's Church, venue of the *Rationalism and Italian Architecture in the Fascist Period* section, 1976.  
Photo Mark E. Smith
- 5, 6, 9 The interiors of the section *Rationalism and Italian Architecture in the Fascist Period*, 1976. Photo Mark E. Smith
- 7 Vittorio Gregotti's portrait at the exhibition, 1976. Photo Cameraphoto
- 8 Opening of the *Rationalism and Italian Architecture in the Fascist Period* exhibition, 1976. Photo Cameraphoto
- 10 Text *Razionalisti e astrattisti italiani negli anni trenta*, Licisco Magagnato, s.d.
- 11 *Biennale: rapporto sull'architettura*  
Avanti!, 20 August 1976, by S. Giannattasio
- 12 Project for the Competition for the Palazzo Littorio in Rome by BBPR, Figini and Pollini, 1976
- 13 Project for the Horizontal city by Giuseppe Pagano, Ignazio Diotallevi, Franco Marescotti, 1976
- 14 *Le temps du fascisme... a Venise*, Jacques Michel  
Le Monde, 11 August 1976

### 4.4A Accademia Internazionale di Danza and Incontri Internazionali della Danza, 1975

In 1975 ballet and dance triumphed at La Biennale di Venezia thanks to the Accademia Internazionale lessons held in the Giardini pavilions, which provided pupils with multifaceted classical and modern training from teachers of many techniques from various countries. The Accademia was directed by Maurice Béjart (1927-2007), a French choreographer famous for his *Sacre du Printemps* and *Bolero*, and Native American star Rosella Hightower (1920-2008). They were also assisted by Mario Porcile (1921-2013), who in those years was the driving force behind a key event for the dance world, the Festival Internazionale del Balletto in Nervi. The Accademia Internazionale trained 686 young dancers from nineteen countries.

A number of important companies led by "creators" such as Maurice Béjart, Martha Graham and Antonio Gades (1936-2004) took part in the parallel Incontri Internazionali. Choreographies by Glen Tetley (1926-2007), Louis Falco (1942-1993) and Robert North (1945-) were presented, and the Balletto del Teatro alla Scala also took part with Carla Fracci (1936-), who would be a lodestar of Italian dance for decades to come. The Hamburg Ballet, Ballet de Marseille, Tokyo Ballet, Budapest State Ballet, Nederlands Dans Theatre – with resident choreographers such as Hans Van Manen (1932-) and Jiří Kylián (1947-) – and Ballets Jazz de Montréal were there, along with many stylised folk traditions from around the world. The programme included two exhibitions, *Dipinti teatrali da Diaghilev a De Basil* at the Central Pavilion and *La danza nel mondo*,

curated by Mario Porcile, with 180 photos by Serge Lido in Teatro La Fenice's Sale Apollinee, in addition to a film series at the Lido about dance stars from Paris to Harlem to Cuba. EGV

- 1 *Notre Dame de Paris*, Ballet de Marseille, Incontri Internazionali della danza, 1975
- 2 *IX Symphonie* by Beethoven, Ballet du XXe siècle, Maurice Béjart, Piazza San Marco, Incontri Internazionali della danza, 1975. Photo Oscar
- 3 Tokyo Ballet Company, Incontri Internazionali della danza, 1975
- 4 Antonio Gades e Cristina Hoyos, Compania de Baile Espanol di Antonio Gades, Incontri Internazionali della danza, 1975
- 5 Nederlands Dans Theater, Incontri Internazionali della danza, 1975  
Photo Tony van Muyder
- 6 Martha Graham Dance Company, Incontri Internazionali della danza, 1975
- 7 *Invasa dal balletto la città di Venezia*  
Il Giorno, 16 June 1975, Lorenzo Arruga
- 8 *Tra mediocre e sublime Béjart in piazza San Marco*  
Il Messaggero, 16 June 1975, Gino Tani
- 9 *La 'Nona' secondo Béjart*  
Il Gazzettino del lunedì, 16 June 1975, Mario Messinis
- 10 *Béjart danza Beethoven in S. Marco*  
Stampa sera, 16 June 1975, Alberto Blandi
- 11, 12 *IX Symphonie* di Beethoven, Ballet du XXe siècle, Maurice Béjart, Piazza San Marco, Incontri Internazionali della danza, 1975
- 13, 15 Incontri Internazionali della danza, 1975
- 14 **Ipad**  
*Accademia Internazionale della Danza*, 1975  
*Serenade*, Balletto del Teatro alla Scala di Milano  
Teatro La Fenice, 1975
- 16, 17, 19 Accademia Internazionale della danza, 1975  
Photo Lorenzo Capellini
- 18 Teatro La Fenice Prima Ballerina Iride Sauri's registration form at the Accademia Internazionale della danza, 1975

#### 4.4B Bob Wilson, *Einstein on the Beach*, 1976

In 1976, fresh from his premiere at the Festival d'Avignon, Bob Wilson (1941-) elevated dance into a "total work of art" in *Einstein on the Beach*, with music was composed by Philip Glass using synthesisers, woodwinds and voices. The original choreographer, Andy De Groat (1947-2019), was replaced by the postmodern Lucinda Childs (1940-), who also wrote and performed some of the texts along with postmodern performers Richard Morrison, Dana Reitz (a pupil of Merce Cunningham) and Sheryl L. Sutton. Breaking all operatic rules and conventions, in four acts made up of brief scenes or "knee plays" without a narrative, *Einstein on the Beach* was groundbreaking even in terms of its relationship with the audience, which was free to come and go throughout the nearly five consecutive hours of this performance "outside of time". EGV

- 1 Brochure, *Einstein on the Beach*, 1976
- 2, 4, 5 *Einstein on the Beach*, 1976. Photo Cameraphoto
- 3 *I prodigi di Bob Wilson*  
Il Gazzettino, 15 September 1976, Mario Messinis
- 6, 8, 9 *Einstein on the Beach*, 1976. Photo Mark E. Smith
- 7, 11, 12 *Einstein on the Beach*, 1976. Photo M. Vitiello
- 10 *Bob Wilson impigliato nel musical*  
Paese sera, 15 September 1976, Elio Pagliarani

- 13 *Il 'violinista' Einstein*  
L'Avanti!, 17 September 1976, Piero Santi
- 14 *'Ballo Excelsior' dell'avanguardia*  
L'Unità, 15 September 1976, Aggeo Savioli

#### 4.5 Luca Ronconi: the crisis and the avant-garde

Luca Ronconi served as the artistic director of the Theatre Department at La Biennale from 1975 to 1977, the year he resigned in protest from the festival board. His 1975 Biennale Teatro was perhaps a unique opportunity for rethinking the theatre, insofar as the concerns that became central after 1968 needed re-evaluation and modification. It was a perhaps unprecedented time of crisis for performance, in which avant-garde theatre companies themselves were questioning the methods and ends of their work: a sort of collective self-criticism meant to be the foundation for building a new relationship with audiences. Not coincidentally, Ronconi called his Biennale an "international theatre workshop", with the word "workshop" suggesting an epoch-making attempt to shift attention from the outcome to the creative act, from the performance to the artistic process underlying and preceding it. He brought in the greatest names in avant-garde theatre at the time, figures still key to any understanding of the art: Jerzy Grotowski, Eugenio Barba, Meredith Monk, Giuliano Scabia, La MaMa, the Living Theatre and Ariane Mnouchkine, to cite just a few creators and supporters of a kind of theatre that was questioning itself, often amidst general incomprehension. FB

#### 4.5A Jerzy Grotowsky, *Apocalypsis cum figuris* and seminar, 1975

A figure who is among the masters of his art in any era, Jerzy Grotowski came to Venice with his latest production, *Apocalypsis cum figuris*, then still in repertory, and also led a seminar for about twenty participants. The work was staged on a small island in the northern part of the lagoon, San Giacomo in Paludo. An irreverent account of profound inner conflict, *Apocalypsis cum figuris* was nevertheless part of a creative process in which the artist had long given up every form of showmanship. This crisis proved to be one of the most significant efforts to bring theatre back to its essence: an unending examination of what we call a "vocation", it was mainly an attempt to think about the actor's craft as a genuine mission, within an approach to theatre where all artifices and frills were systematically rejected: a realm of pure exploration, entirely removed from any mechanism or logic of production. FB

- 1-3 Jerzy Grotowski and Peter Brook, Scientific session at Mirano, 1975.  
Photo Lorenzo Capellini
- 4, 6 Jerzy Grotowski and Luca Ronconi, Uniwersytet Pozzukiwan Wroclaw, 1975
- 5 Jerzy Grotowski and Peter Brook, Uniwersytet Pozzukiwan Wroclaw, 1975
- 7, 8 Jerzy Grotowski at the XI Scenic Seminar,  
*Apocalypsis cum Figuris*, 1975.  
Photo Mark E. Smith



- 9, 10 Jerzy Grotowski, Luca Ronconi at the XI Scenic Seminar, *Apocalypsis cum Figuris*, 1975. Photo Lorenzo Capellini
- 11, 13-17, 25 *Special Project*, Jerzy Grotowski, stage with the research groups, 1975. Photo Lorenzo Capellini
- 12 Poster for the XI Scenic Seminar, *Apocalypsis cum Figuris*, 1975. Photo Mark E. Smith
- 18-24 *Apocalypsis cum Figuris* by Jerzy Grotowski, 1975. Photo Lorenzo Capellini

## 4.5B Eugenio Barba, *Immagini da una realtà senza teatro*, 1975

Eugenio Barba, the founder of Odin Teatret, came to La Biennale for an encounter with his audience titled *Immagini da una realtà senza teatro* (Images from a World without Theatre). The time turned out to be ripe for describing the working methods of a collective which was coming up with novel methods of performance and interaction. Via experiences of migration and travel, Odin developed practices of exchange such as “bartering”, in which different cultures offered their respective skills to each other in an approach that explicitly rejected the power of money. This bold theatrical and social concept set out from the start to challenge the individual conscience, never providing answers and, above all, continually questioning itself. FB

- 26 Text curated by Eugenio Barba, 1975
- 27, 30, 31 *Images of a theatre-less reality*, Odin Teatret, Eugenio Barba, 1975. Photo Mark E. Smith
- 28, 29, 32, 33 *Images of a theatre-less reality*, Odin Teatret, Eugenio Barba, 1975. Photo Lorenzo Capellini

## 4.5C La MaMa Experimental Theatre Club, *Fragments of a Trilogy*, 1975

Directed by Romanian-born Andrei Șerban, *Fragments of a Trilogy* (*Medea, The Trojan Women, Electra*) is still one of this New York troupe’s most famous productions. Judged by The New York Times to be “nothing less than a reinvention of theater”, the work stands out for its significant linguistic experimentation, featuring the use of Ancient Greek and Aztec dialects. Accompanied by the music of Elizabeth Swados, a famous composer and director, *Fragments of a Trilogy* was a clearly innovative piece, a reworking of ritual in which words become archaic sound, in an experience encompassing all of the audience’s senses. FB

- 1, 2, 4, 5, 7, 8 *Fragments of a trilogy. Euripides. Sophocles. Seneca*, by Andrei Șerban, 1975. Photo Lorenzo Capellini
- 3, 6 *Fragments of a trilogy. Euripides. Sophocles. Seneca*, by Andrei Șerban, 1975. Photo Mark Smith
- 9 Draft for the scenography of the performance, 1975

## 4.5D Living Theatre, *The Legacy of Cain* 1975

On its second visit to Biennale Teatro, in 1975, the Living Theatre presented a play cycle titled *The Legacy of Cain*, inspired by Leopold von Sacher-Masoch. What this American group primarily questioned in this work was the concept of revolution, coming down in favour of action outside the confines of the theatre arts and increasingly carried out in outdoor spaces. This can be seen in what was called a “secular Via Crucis”, *Six Public Acts*, the first part of the evil Cain’s legacy: a sort of procession through the symbolic places of political and economic power in Venice, past the stock exchange building, here rechristened the “House of Death”, to Piazza San Marco, the “House of the State”. The Living Theatre’s last appearance in Venice may now seem a utopia of collective activism doomed to be defeated by consolidated resistance, as the company co-founder Julian Beck himself admitted in 1983: “The theatre [is] again in the hands of the bourgeoisie.” FB

- 10 *Caino e Abele per Venezia*  
La Stampa, 22 October 1975, Alberto Blandi
- 11 *Anche il living s’intono alla Biennale della fatica*  
Il Tempo, 17 October 1975, Giorgio Prosperi
- 12, 13 Julian Beck and Judith Malina during the press conference, 1975. Photo Cameraphoto
- 14 *È possibile salvare il Living Theatre?*  
Il Giorno, 22 October 1975
- 15 Text curated by the Living Theatre, 1975
- 16 Living Theatre’s leaflet. *The Beginning of a process of social creation*, 1975
- 17, 19 Presentation and poetic acts by the Living Theatre, 1975
- 18 Draft of the lineup for *The Legacy of Cain – The Money Tower*, 1975
- 20, 21 Minutes of the Theater Commission’s meeting, 23 February and 6 May 1977
- 22-27, 35-37 *The Legacy of Cain. Six Public Acts*, Living Theatre Collective, 1975. Photo Lorenzo Capellini
- 28-30 Draft of the script for *The Legacy of Cain -The Money Tower*
- 31-33 *The Legacy of Cain. Six Public Acts*, Living Theatre Collective, 1975. Photo Mark E. Smith
- 34 *The Legacy of Cain. Six Public Acts*, Living Theatre Collective, 1975. Photo Cameraphoto
- 38 *Che cosa è rimasto del celebre Living Theatre*  
L’Unità, 21 October 1975, Aggeo Savioli
- 39 *Le statue dell’orrore*  
Paese Sera, 20 October 1975, Elio Pagliarani
- 40 *The Legacy of Cain. Seven Meditations on Political Sadomasochism*. Living Theatre, 1975. Photo Mark E. Smith
- 41 *Ma cosa xelo, questo living?*  
Il Resto del Carlino, 16 October 1975, Sergio Colomba
- 42 *Atti di sadomasochismo*  
Il Gazzettino, 21 October 1975, G.A. Cibotto
- 43-45 *The Legacy of Cain. Seven Meditations on Political Sadomasochism*, Living Theatre, 1975. Photo Lorenzo Capellini

### Monitor

*Six Public Acts*, Living Theatre, 1975

## 4.5E Ariane Mnouchkine, *L'Âge d'or*, 1975

Théâtre du Soleil founder Ariane Mnouchkine had already been invited to Biennale Teatro in 1968 with her staging of Arnold Wesker's *The Kitchen*. In *L'Âge d'or*, the artist and her ensemble made a powerful political statement by presenting their own unique Harlequin, an Algerian one. The tale of the abuse suffered by the main character is told using commedia dell'arte masks and conventions. Performed three times out-of-doors in Campo San Trovaso, the play questioned theatre's role in history, as part of an investigation that tried to foster change by highlighting, sometimes with wry humour, the injustices and contradictions of socio-economic progress. This is a mission, as Ariane Mnouchkine still likes to call it, that has always guided her work, a theatrical struggle against all forms of barbarity, disparity and intolerance. FB

- 1, 2 *L'Âge d'or*, Théâtre du Soleil, Ariane Mnouchkine, 1975  
Photo Mark E. Smith
- 3 Ariane Mnouchkine's portrait. Photo Mark E. Smith
- 4 *L'Âge d'or*, Théâtre du Soleil, Ariane Mnouchkine, 1975
- 5 *L'Âge d'or*, Théâtre du Soleil, Ariane Mnouchkine, 1975. Photo Lorenzo Capellini
- 6 *L'Âge d'or*, staging, campo San Trovaso, 1975. Photo Lorenzo Capellini
- 7 Carlo Ripa di Meana and Ariane Mnouchkine, 1975. Photo Lorenzo Capellini

### Monitor

*L'Âge d'or*, Ariane Mnouchkine, 1975

## 4.5G Meredith Monk, *Education of the Girlchild*, 1975

With *Education of the Girlchild*, performed four times at the former shipyards on Giudecca, Meredith Monk made her first appearance in Italy and was probably the 1975 International Theatre Festival's most explosive discovery. An artist and performer who has always resisted labelling, Monk managed in this work to blend the spiritual with the everyday, lament with heartfelt prayer, in a compelling crescendo that featured an entirely innovative use of vocal technique. Here it was the traditional notion of text that was pushed to the breaking point, with words frequently crumbling into phonetic sequences evocative of ancestral archetypes. Even today, Meredith Monk's exploration of sound remains one of the most important investigations in theatre and in musical composition. FB

### Monitor

*Education of the Girlchild*, Meredith Monk, 1975

## 4.5F Amelio 'Memè' Perlino, *Tradimenti n.2*, 1975

Hosted by the Biennale Teatro in 1976, Perlino was one of the most significant exponents of what has been called "image theatre", a movement which favoured the creative process of stage direction over the script or word-based drama. A visual artist who also worked in film, Perlino came to critical and public attention very young with his dazzling reinterpretations of classics like *Othello* and *Spring Awakening*. He became a prominent figure on the Roman avant-garde scene of "cellar theatres", and his *Tradimenti n. 2*, an installation/play presented at the former Giudecca shipyards, was a sort of neo-Surrealist performance that continued on this path of divergence from traditional theatre. FB

- 8, 13 *Tradimenti n. 2*, by Memè Perlino, 1976. Photo M. Vitiello
- 9-11 *Tradimenti n. 2*, by Memè Perlino, 1976. Photo Cameraphoto
- 12 *Tradimenti n. 2*, by Memè Perlino, 1976
- 14, 15 Memè Perlino's portrait, 1976. Photo Cameraphoto

### Panel

Poster of B 76. *Tradimenti n. 2*. Perlino, Aglioti, Davies, 1976

# ROOM 5

## *FREEDOM FOR CHILE,* 1974

In September 1973 a military coup led by General Augusto Pinochet overthrew the democratically elected Chilean government of Salvador Allende, who died in the attack on Palacio de La Moneda. The news shocked the entire world. La Biennale, which had just appointed its new board of directors with Carlo Ripa di Meana as president, immediately decided to dedicate that year to "Freedom for Chile". The underlying theme was the expulsion of culture by dictatorships, in this specific case from Pinochet's Chile, where many literary and artistic as well as political figures were forced into exile. It was a highly politicised subject meant to bring La Biennale back into the public and media spotlight. The 1974 exhibitions were thus not just focused on visual art but drew on other fields, bringing together film, music, theatre, photography and painting. All kinds of venues were employed, across Venice and in neighbouring towns. On 5 October 1974 events opened at Palazzo Ducale with a packed conference titled *Testimonianza contro il fascismo* (Bearing Witness against Fascism), telling the stories of artists, intellectuals and politicians under dictatorships in Italy and elsewhere. Hortensia Allende, the Chilean president's widow, was among those in attendance. Many Italian and international artists went out into the squares to make large paintings showing their solidarity with the South American country; they included the Chilean artist Sebastian Matta, who painted two murals in Campo San Polo, and Spanish artist Eduardo Arroyo, leader of a "Brigada Salvador Allende" made up of Italian painters like Vittorio Basaglia, Vincenzo Eulisse, Paolo Gallerani, Alberto Gianquinto, Silvestro Lodi, Lino Marzulli, Fabrizio Merisi, Giorgio Nonveiller, Paolo Pennisi, Marcello Pirro, Giovanni Rubino, Guido Sartorelli, Tino Vaglieri and other students from the local art academy and from the secondary school for the arts in Treviso. Recurring themes and slogans in the murals included *El pueblo unido jamás será vencido* ("The people, united, will never be defeated": the beginning of a famous song associated with the Chilean Unidad Popular movement), verses by Pablo Neruda, and emblematic images of raised hands, closed fists, red stars and faces, either serious or shouting. In addition to this spontaneous gesture, La Biennale's Central Pavilion housed an exhibition

about political posters in Chile: over one hundred works made with different techniques which had appeared in Chilean cities between 1970 and 1974, that is, between Salvador Allende's entry into office and the subsequent coup. There were also many theatrical performances and concerts, including one by the Inti-Illimani folk ensemble. VP

*Murales* painted by the Brigada Salvador Allende and the students of the Liceo Artistico di Treviso, in Venice and the surrounding territory  
Latex paint and charcoal on particle board, 300x300 cm

Periodical in five numbers *Libertà al Cile* with the related posters, 1974  
File curated by the Archivio Storico delle Arti Contemporanee della Biennale di Venezia

- 1, 4-7 *Mostra del manifesto cileno*, Italian pavilion, 1974
- 2 Hortensia Bussi, Allende's widow, visits the *Mostra del manifesto cileno* exhibition, Italian pavilion, 1974
- 3 *Mostra del manifesto cileno*, Italian pavilion, 1974. Photo Luca Rossi
- 8 *Mostra del manifesto cileno*, Italian pavilion, 1974. Photo Mark E. Smith
- 9, 13 Photography exhibition, *Freedom for Chile*
- 10 Photography exhibition, *Freedom for Chile*, campo San Polo, 1974
- 11 Photography exhibition, *Freedom for Chile*, Chioggia, 1974. Photo Mark E. Smith
- 12 Photography exhibition, *Freedom for Chile*, piazzale Candiani, Mestre, 1974. Photo Mark E. Smith
- 14, 15 Carlo Ripa di Meana  
Meetings of the Chilean artists with cultural, political and trade union representatives, Porto Marghera, 1974
- 16 Chilean Popular Music, Inti-Illimani, Petrolchimico, Porto Marghera, 1974
- 17, 18 Chilean Popular Music, Inti-Illimani, tent in campo San Polo, 1974. Photo Mark E. Smith
- 19 Hortensia Bussi, Allende's widow,  
Chilean Popular Music, Inti-Illimani, Petrolchimico, Porto Marghera, 1974
- 20 Chilean Popular Music, Inti-Illimani, Italian pavilion, 1974  
Photo Mark E. Smith
- 21, 22 Chilean Popular Music, Inti-Illimani, tent in piazzale Candiani, Mestre, 1974
- 23 Sebastian Matta paints the mural in campo San Polo, 1974.  
Photo Lorenzo Capellini
- 24 The Murals, campo San Polo, 1974. Photo Lorenzo Capellini
- 25, 26, 28, 29, 31-35, 38-41 The Murals, campo San Polo, 1974
- 27, 30 Sebastian Matta paints the murals in campo San Polo, 1974.  
Photo Mark E. Smith
- 36, 37 Sebastian Matta paints the murals in campo San Polo, 1974
- 42-44, 47-50, 52, 53, 55, 57 The Murals, campo Santa Margherita, 1974
- 45 The Murals, campo Santa Margherita, 1974. Photo Lorenzo Capellini
- 46 The Murals, campo Santa Margherita, 1974. Photo Luca Rossi
- 51, 54, 56 The Murals, campo Santa Margherita, 1974. Photo Mark E. Smith
- 58-60 The Murals, Marghera, 1974. Photo Mark E. Smith
- 45 46 51, 54, 56 58-60 61-64, 66 The Murals, Mira, 1974
- 65 The Murals, Mira, 1974. Photo Mark E. Smith
- 67, 69, 70 The Murals, Chioggia, 1974
- 68 The Murals, Chioggia, 1974 Photo Mark E. Smith

## Monitor

*Murales 1974*, by Michele Sambin and Sergio Ballini, 1974  
*Murales 1974*, by Raul Ruiz, 1974

## Panel

Poster *Il popolo tortura chi brucia*  
From the five-number periodical *Libertà al Cile* and relative manifests, 1974  
File curated by the Archivio Storico delle Arti Contemporanee della Biennale di Venezia

Poster for La Biennale, 4th November 1974

Poster for *Arrestato in Spagna Eduardo Arroyo*.  
Commissioner of La Biennale di Venezia, 1974

Poster for *Una cultura democratica e antifascista*, 1974. Unimark

Poster for *Testimonianze contro il fascismo*, 1974. Unimark

# ROOM 6

## SOFIJA GUBAJDULINA, APPLIED MUSIC AND ABSOLUTE MUSIC

Today, Sofia Gubaidulina's life story and artistic experiences, like the Golden Lion at the 2013 Biennale Musica, seem like a long adventure. It began when the Soviet Union was a vast, powerful empire, and a girl born in Chistopol, Tatarstan in 1931 fell in love with music. She studied piano and composing at Kazan and then Moscow. She was talented, but wanted to find her own voice without making any aesthetic or linguistic compromises, an attitude that the regime considered highly suspect and dangerous. In the Soviet Union of the 1950s and '60s knowledge of contemporary Western music was extremely fragmentary and episodic, and it was above all Webern and Shostakovich's lessons in freedom that encouraged her to go her own way, wherever it led her. The context in which the young composer trained and embarked on her career was complex and contradictory, however. Whilst the regime's official organs condemned stylistic experimentation and the use of Western avant-garde techniques (seriality, electronic music, musique concrète, aleatoric music) in accordance with the canons of Socialist Realism, the Soviet music scene was actually quite varied and complex, with many impulses towards innovation. The 1970s were especially difficult: like other composers of her generation such as Edison Denisov and Alfred Schnittke, Gubaidulina paid for her modernist attitudes and refusal to accept the regime's restrictions with exclusion from the official Soviet music world. In the 1980s a breath of fresh air swept in with the new political climate and brought new opportunities: for Gubaidulina it was the decade when she rose to prominence, even abroad. With its singular balance between ingenious construction and expressivity, her language evades labelling. Across half a century, the aesthetic and style that gave it substance constantly evolved and explored new perspectives, moving out concentrically, piece after piece, from a solid generative core. This core comes from a combination of different, interwoven elements: the spiritual origin and ethical urge of art-making, as a search for life's profound, mysterious meaning; the need to put everything that to us seems scattered and

discordant back into a single, organic whole; a musical dramaturgy whose ritual, performative, gestural and narrative components are reconciled deep within a theatre of memory devoid of spectacle, where the object is not the image of action but the action itself.  
CF

## 6.1 *Adventures of Mowgli* and the 2013 Golden Lion

In the Soviet Union, composing soundtracks and theatrical scores became a source of income for many composers excluded or marginalised from the regime's official channels and milieus, including Edison Denisov (1929-1996), Andrei Volkonsky (1933-2008), Alfred Schnittke (1934-1998), Giya Kancheli (1935-2019), Arvo Pärt (1935) and Valentin Silvestrov (1937). For Sofia Gubaidulina (1931), too, writing "utilitarian", "applied" music was a major source of income for a few decades, and at the same time an opportunity for stylistic and expressive experimentation. In this sense, the soundtrack that Gubaidulina wrote for the animated film *Maugli* (Adventures of Mowgli) by Roman Davidov (1913-1988) is of especial interest. Inspired by Rudyard Kipling's *The Jungle Book* – as was the 1967 Disney film by Wolfgang Reitherman – *Maugli* (1973) is composed of five short films lasting twenty minutes each, made from 1967 to 1971 and then assembled into a feature length film in 1973. CF

## 6.2 "Khrennikov's Seven": Russian composers at the Biennale of Dissent

Several concerts at the 1977 Biennale of Dissent and then at the 1979 edition featured the music of dissident Soviet composers, or composers disliked by the regime. It was in the wake of events such as these in the West that towards the end of the Brezhnev era, in November 1979, the powerful secretary general of the Soviet Composers Union, Tikhon Khrennikov (appointed in 1948 by Zhdanov) publicly condemned the music of seven composers, calling them "pointlessness [...] and noisy mud instead of real musical innovation". The so-called Khrennikov Seven, who were actually very different from one another, were also accused of having taken part in certain festivals without the required authorisation: Vyacheslav Artyomov (1940-), Edison Denisov (1929-1996), Elena Firsova (1950-), Sofia Gubaidulina (1931-), Alexander Knaifel (1943-), Dmitri Smirnov (1948-2020) and Viktor Suslin (1942-2012) were thus put on an official Soviet blacklist. CF

- 1 Music Sector Events calendar, 1977
- 2 Provisional Programme of the Dissenso Culturale, 1977
- 3 Poster for B 77. *Sovetskaja Muzyka*, Design Messina & Montanari, 1977
- 4 Programme of La Biennale Musica 1979, Tuesday 2nd October, 6 pm, Teatro La Fenice - Sale Apollinee, 1979
- 5-10 Score of *Rumore e Silenzio*, Sofia Gubaidulina, 1974-1975

### Monitor

The Golden Lion for Lifetime Achievement awarded to Sofia Gubaidulina, 2013

Roman Davidov's animated film *Maugli*, soundtrack by Sofia Gubaidulina, 1973

# ROOM 7

## THE BIENNALE OF DISSENT, 1977

The 1977 “Biennale of Dissent” was the first act of political and cultural support in Italy for the many people involved in various forms of resistance in the Soviet Union and other Communist countries. The project, a brainchild of Carlo Ripa di Meana (who conceived the event without the approval of the board of directors), met with immediate pushback from the Soviet government, which exerted all sorts of pressure on the Italian government – especially the Italian Communist Party, which was initially enthusiastic but then forced by threats from Moscow to oppose the idea. Apart from the government, opposition to Ripa di Meana’s idea also came from the Italian cultural elite, including Roman mayor and respected art critic Giulio Carlo Argan, who railed against it. On La Biennale di Venezia’s board, Ripa di Meana was forced to accept the resignations of Gregotti, Gambetti and Ronconi and to soldier on alone in his organisation of the event with little outside support, as he himself recalls: “During the difficult gestation of that Biennale, the only people backing me were really Bettino Craxi and Claudio Martelli, along with the De Michelis brothers and a few others.”

The Biennale of “Cultural Dissent” took place from 15 November to 15 December 1977. The programme included four exhibitions scattered around the city: *New Art from the Soviet Union: An Unofficial Perspective*; *Czechoslovak Graphics: Eleven Years of Experimentation, 1965-1975*; *Theatre Posters and Photographs*; *Books, Magazines, Photographs, Videotapes, Samizdat*. There were also seven intercultural conferences (on history, visual arts, film, religion, literature, theatre, science); performances by Wolf Biermann, Alexander Galich, Alexei Khvostenko, Karel Kryl, Joseph Brodsky and five *Sovetskaya muzyka* (Soviet music) concerts. In addition, there was a film survey on the theme of Eastern Europe, a number of roundtables, and a seminar on the work of Soviet director Sergei Parajanov, imprisoned for homosexuality. On 15 November 1977 the events opened in Museo Correr’s Napoleonic Wing with the public reading of a statement from dissident Andrei Sakharov, the theoretical physicist who won the Nobel Peace Prize in 1975. Poets Joseph Brodsky and Viktor Nekrasov,

philosopher Leszek Kołakowski and singer-songwriter Alexander Galich were also present, as were Susan Sontag, André Glucksmann, François Feitö, Alberto Moravia, Norberto Bobbio, Dario Fo, Gillo Dorfles, Renato Mieli, Paolo Flores D’Arcais, and Bettino Craxi. The Italian context in which the Biennale of Dissent came about was highly complex: bombings, protests and shootings were taking place across the country, in a period that would later be called the “years of lead”. In spring 1978 the kidnapping and killing of Christian Democrat leader Aldo Moro was the event that most shocked the public. It was Moro, in the months prior to his kidnapping, who had brought about an extremely important agreement between Italy’s two largest parties, his own centrist DC and the Italian Communist Party. The agreement led to what was known as the “historic compromise” with PCI secretary Enrico Berlinguer. VP

## 71 The Parajanov protest

*Cinema e paesi dell'est* (Cinema in Eastern European Nations), held at Cinema Olimpia and Teatro Malibran in November 1977, was the largest survey of dissident films from socialist countries ever to be held in the West. Directors included Věra Chytilová, István Gaál, Juraj Jakubisko, Otar Iosseliani, Andrei Michalkov-Konchalovsky, Jan Němec, Evald Schorm, Andrei Tarkovsky, Jiří Trnka, Andrzej Wajda, Krzysztof Zanussi and Andrzej Żuławski. Many of them were well known and some of their films had already been seen, but little was known about Sergei Parajanov. In 1968 the Armenian director had signed a petition protesting the arrest of Ukrainian intellectuals, and for this reason the filming of *Sayat-Nova* – or *Tsvet granata* (The Colour of Pomegranates), the title of Sergei Yutkevich's recut 1971 version – was halted and was only completed in 1969. The movie was immediately withdrawn for "extreme deviation from Russian realism". In 1974, while he was working on a new film, Parajanov was arrested and sentenced to five years of hard labour for homosexuality, trafficking in art objects and incitement to suicide.

Fifteen days before the Venetian event, Angelo Pezzana, leader of the gay rights movement Fuori!, was expelled from the USSR for actions in support of Parajanov. Pezzana's protest continued in Venice and Ripa di Meana transformed a seminar on the director into a "solidarity meeting", alongside various international movements led by Surrealist Louis Aragon, which concluded with appeals for the director to be released and his films to circulate freely. *Tini zabutykh predkiv* (Shadows of Forgotten Ancestors) and *Sayat-Nova* were shown at the Olimpia, after an introduction in which Lino Micciché – who in 1997 would become president of La Biennale – read out a statement of protest addressed to the Soviet government and signed by filmmakers and critics. GG

### Monitor

*Teni zabytykh predkov* by Sergej Paradžanov, 1964

*Sayat nova* by Sergej Paradžanov, 1970

## 72 New Art from the Soviet Union: An Unofficial Perspective, curated by Enrico Crispolti and Gabriella Moncada, 1977

The exhibition *La nuova arte sovietica: Una prospettiva non ufficiale* (New Art from the Soviet Union: An Unofficial Perspective), curated by Enrico Crispolti (1933-2018) and Gabriella Moncada, showcased artworks alongside photographic and video documentation, gathering the work of a hundred or so artists active in the Soviet Union and other countries. Their pieces mainly belonged to private Italian collections, and some paintings and sculptures which could not be secured were shown in slide projections. The exhibition was meant to be an "unofficial perspective" in the sense of divergent from the state-approved style, Socialist Realism. Held at the Arsenale's Palazzetto dello Sport, the show was divided into seven sections: *Expressionist Figuration and Lyrical Figuration; Action, Matter, Image;*

*Post-Constructivist and Organic Abstraction; Kinetic Art; Surreal Figuration; Humour and More, Exploring the Everyday; Conceptual Mediation, Behaviour and Collective Action.* The most interesting contributions included the cybernetic experiments of the Dvizhenie movement, the work of Ilya Kabakov and Alexander Melamid, Vitaly Komar, Rimma Gerlovina, Valeriy Gerlovin, Francisco Infante Arana and the CAG group, made up of Nikita Alexeev, Georgii Kizevalter and Andrei Monastyrsky. The projects focused on dissent and the exhibition by Enrico Crispolti (a professor of contemporary art history) had an extremely powerful echo in the Italian press, highlighting the range of orientations – and of relationships with the Soviet Union – in the Italian Left.

### Projectors

A selection of 160 slides among the ones that were projected during the *New Art from the Soviet Union: An Unofficial Perspective* exhibition, Biennale 1977

## 73A The Samizdat and art-tapes exhibitions

On 15 November, an exhibition opened at Museo Correr that explored *samizdat*, self-published work. This was a very widespread phenomenon in Soviet countries, especially in the 1960s and '70s, among those seeking to evade censorship and state publishing; the Russian word *samizdat* was used to describe the typewritten production of banned texts on tissue paper. Very few copies could be made this way, but anyone who came into possession of one was supposed to replicate it in turn to disseminate new texts, in disciplines ranging from art to politics and from religion to science. Closely tied to the word *samizdat* was *tamizdat*: a text which reached the West as *samizdat*, was printed in book or pamphlet form, and returned to the Soviet Union. *Magnetizat* (or *magnitizadat*), on the other hand, was oral, recorded *samizdat*. The exhibition displayed all these forms of cultural expression, bringing thousands of documents to Venice. From June to December 1977, in addition to the exhibitions, La Biennale held dozens of conferences, seminars and workshops. In October and November, for example, some of the *art-tapes* videos produced by Maria Gloria Biccocchi were presented to the public at the new ASAC site in Ca' Corner della Regina. Called *art/tapes/22*, the production included work by Marina Abramović, Vito Acconci, Allan Kaprow, Ketty La Rocca, Urs Lüthi, Dennis Oppenheim and Bill Viola.

## 73B The end of Carlo Ripa di Meana's presidency

The 1977 Biennale was an overall success. The events focused on dissent were covered by 763 international journalists, twenty-five Italian radio and TV stations and fifteen international ones; 350 scholars from a range of different countries took part, and over 220 thousand people visited the *Samizdat* exhibition at Museo Correr. Ripa di Meana stayed on at the helm and also reconfirmed the board of directors. The theme chosen for 1978 could not have seemed further from politics – "From Nature to Art and from Art to Nature" – but as the president himself explained, this topic actually opened up "new possibilities



of participation for both highly industrialised countries and for others whose social, historical and cultural lives are very different.” Luigi Scarpa, who had already taken an organisational role in the 1976 edition, was appointed artistic director of the Visual Arts department, and the Italian pavilion was to be overseen by Luigi Carluccio, Enrico Crispolti and Lara Vinca Masini. It was unclear whether the Soviet Union and its satellite nations would be there. Only at the end of April 1978 did their unwillingness to attend become less unanimous, with the announcement that Romania would take part. After the events of 1977, many Eastern Bloc countries did not come to the Biennale for years. For the 1978 edition the Biennale Arte returned to the Giardini di Castello. The nature theme was explored, in the main exhibition, through *Sei stazioni per artenatura: La natura dell'arte* (Six Stations for Art-Nature: The Nature of Art). Curated by Jean Cristophe Amman, Achille Bonito Oliva, Antonio del Guercio and Filiberto Menna, it was a critical re-reading of modern art in relation to the environment. At the end of this Biennale, Ripa di Meana did not seek reappointment, and in 1979 he ran and was elected to the first European parliament.

## Panel

Poster for B.77 *Il dissenso culturale*, 1977  
Francesco Messina, Ferruccio Montanari

Poster for B.77 *Il dissenso culturale. 15 novembre - 15 dicembre*, 1977  
Francesco Messina, Ferruccio Montanari

Poster for B.77 *La nuova arte sovietica. Una prospettiva non ufficiale*, 1977  
Francesco Messina, Ferruccio Montanari

Poster for B.77 *Libri. Riviste. Manifesti. Fotografie. Videotapes. Samizdat*, 1977  
Francesco Messina, Ferruccio Montanari

- 1 Letter from Carlo Ripa di Meana to Alexandr Georgevic Chalturin, 31 August 1976
- 2 Exhibition signage *Il Dissenso culturale*, 1977
- 3 Enrico Crispolti and Gabriella Moncada at the conference *Avanguardie e neoavanguardie nell'est europeo*, 1977. Photo Mark E. Smith
- 4 Message to La Biennale from the Nobel Prize Andrej Sacharov, 5 November 1977
- 5 Presentation of the programme *Dissenso Culturale* of La Biennale di Venezia, 1977
- 6 Telegram from Antonio Delguercio to Carlo Ripa di Meana, 4 October 1977
- 7 Exhibition signage *Il Dissenso culturale*, 1977. Photo Cameraphoto
- 8 Moments of the convention *Il Cinema nazionalizzato*, 1977. Photo Mark E. Smith
- 9 The President of La Biennale Carlo Ripa di Meana talking to the Secretary of the P.S.I. (Partito socialista italiano) Bettino Craxi at the conference *Libertà e socialismo* during the Biennale of Dissent, 1977. Photo Cameraphoto Modena
- 10 **Ipad**  
*Samizdat* Biennale 1977  
TG2 news service about the Biennale of Dissent and interview to Carlo Ripa di Meana about his decision of resigning as the President of La Biennale, Rai, 1977  
Carlo Ripa di Meana's resignation's withdrawal, Rai, 1977
- 11 Visitors at the *New Art from the Soviet Union: An Unofficial Perspective*, 1977. Photo Cameraphoto Modena
- 12 Exhibition design project, 1977
- 13 *Specchio rotto*, Ilya Kabakov, 1966. Photo Studio Giacomelli
- 14 *Le Mouches*, Ilya Kabakov, 1969
- 15 *Le Mouches* and *Dans l'appartement*, Ilya Kabakov, 1969. Photo Studio Giacomelli
- 16 Note for the President Carlo Ripa di Meana, 26 September 1977
- 17 Ilya Kabakov's portrait, 1977. Photo Studio Giacomelli
- 18 *Bevete Breznev-Cola*  
*L'Espresso*, 7 March 1976, Umberto Eco
- 19 *Attention!*, by Erik Boulatov, 1977
- 20 Eduard Zelenin before his artwork *Madonna*, 1977
- 21 Lev Nussberg, 1977. Photo Cameraphoto
- 22 *Where is the lines between us?*, Komar & Melamid, 1977
- 23 *Cortina di ferro*, Gennady Donskoy and Mikhail Roshal-Fedorov, 1977
- 24 Visitors at the *New Art from the Soviet Union: An Unofficial Perspective* exhibition, 1977

# ROOM 8

## THE FIRST INTERNATIONAL ARCHITECTURE EXHIBITION AND POSTMODERNISM, 1980

Architecture officially became its own separate department for the first time during Giuseppe Galasso's four-year presidency (1979-1982). Galasso appointed Paolo Portoghesi to be artistic director, with four co-curators: Charles Jencks, Christian Norberg-Schulz, Vincent Scully and Kenneth Frampton. After Aldo Rossi's *Teatro del Mondo*, a temporary building anchored to Punta della Dogana in 1979-80, the new director curated the first International Architecture Exhibition, titled *La presenza del passato* (The Presence of the Past).

The theme driving this first exhibition was postmodernism, which challenged modernism's aspirations toward innovation, technology, free-plan spaces and pure geometric forms. Postmodernism, whose theorists included Charles Jencks, presented a new vision of history as a boundless reservoir of images and evocations from which architects could freely borrow forms, styles and decorative elements. This was the idea which inspired Portoghesi's *Strada Novissima*, the key exhibition at the Corderie of the Arsenale, whose historic space was opened to the public for the first time for the Biennale. *Strada Novissima* consisted of twenty facades designed by famous architects as if they were a theatrical backdrop, a hypothetical "street" of postmodern buildings. It offered visitors a direct, tactile experience of architecture, in an exhibition that was "with architecture rather than about architecture", as Portoghesi said. Famous architects from all over the world were invited to help create this *Strada Novissima*, which fostered a lively debate about postmodernism and became a symbol of the movement. They included Frank O. Gehry, Michael Graves, Hans Hollein, Rem Koolhaas, Arata Isozaki, Robert Venturi and Denise Scott Brown.

With its first architecture exhibition, La Biennale became an important part of the international architecture debate, given its ability to bring the very latest developments and experiments to Venice. With

Aldo Rossi's *Strada Novissima* and *Teatro del Mondo*, the postmodernist movement achieved international recognition.

That same year, the Visual Arts department inaugurated the first edition of *Aperto* (Open), La Biennale di Venezia's new section for young artists, which continued until 1993. In the context of the 1980s, *Aperto* registered and absorbed new impulses similar to those found in the first Biennale Architettura; it marked the birth of a postmodern sensibility that transcended the rules of modernism and the great ideological narratives of the twentieth century, rekindling an interest in history, eclecticism and the joys of the ephemeral.

A similar sensibility could also be seen the 1984 and 1986 editions of Biennale Arte directed by Maurizio Calvesi, titled *Arte e Arti – Attualità e Storia* (Art and Arts – The Current Situation and History, 1984) and *Arte e Scienza* (Art and Science, 1986), which were particularly noteworthy for their blending of contemporary and ancient art forms. MCC

## 8.1 *La Strada Novissima*, curated by Paolo Portoghesi, 1980

In 1980 La Biennale inaugurated the Architecture department as its own section. On 27 July of that same year the first International Architecture Exhibition, *La presenza del passato* (The Presence of the Past) was held, under the direction of Paolo Portoghesi with the assistance of four co-curators – Charles Jencks, Christian Norberg-Schulz, Vincent Scully and Kenneth Frampton. *La Strada Novissima*, curated by Portoghesi himself, was presented at the historic site of the Corderie in the Arsenale, opened to the public for the first time. Twenty architects from all over the world were invited to reflect on the relationship between architectural heritage and the avant-garde, exploring the idea of the city street as a sort of stage set. They designed twenty life-size house facades built by artisans from the Cinecittà film studios, which together comprised a seventy-metre-long, six-metre-high installation. This “gallery of architectural self-portraits”, as Portoghesi himself defined it, included work by the Italians Costantino Dardi, Paolo Portoghesi with Francesco Cellini and Claudio D’Amato, Franco Purini with Laura Thermes, Studio GRAU and Massimo Scolari, as well as international architects like Ricardo Bofill, Frank O. Gehry, Michael Graves, Allan Greenberg, Hans Hollein, Arata Isozaki, Josef Paul Kleihues, Rem Koolhaas, Léon Krier, Charles W. Moore, Thomas Gordon Smith, Robert A. M. Stern, Stanley Tigerman, Oswald Mathias Ungers, and Robert Venturi with Denise Scott Brown and John Rauch. Behind each facade was a room documenting each architect’s most significant work. Aldo Rossi designed the entrance portal. *La Strada Novissima* was a concrete metaphor for architecture as spectacle and revealed a new way of thinking about the discipline. By rediscovering the liberating power of practices like eclecticism and revival that had been frowned upon by modernism, it brought the international debate on postmodern architecture into the heart of La Biennale. Inside the Corderie, three solo exhibitions of work by Ignazio Gardella, Philip Johnson and Mario Ridolfi also contributed to exploring architectural roots, the central theme of the event. The upper floors of the Corderie showcased the work of seventy-six other architects, including Alessandro Mendini, Paola Navone, Daniela Pupa and Franco Raggi, who presented *Oggetto banale* (Banal Object) – a collection of forty everyday items – as well as a painting, a “banal” architectural model, and a room. Amidst the crisis in radical architecture, the idea of “banal design” was advanced by Mendini as a possibile path of future development and innovation. The exhibition and the *Strada* drew vast coverage in the international press, showing how useful it was to expand the debate beyond the specialised critical milieu. By organising the first International Architecture Exhibition at the Arsenale and symbolically recreating a piece of the city inside it, La Biennale expressed the hope that one of Venice’s most vital spaces would be restored to public use. MCC

### Blow-up

- Prospective view of *La Strada Novissima*, 1980
- 1 Entranceway, *La Presenza del Passato*, Aldo Rossi, 1980
  - 2 *The Presence of the Past: The International architecture Exhibition from the Venice Biennale* leaflet, San Francisco, 1982

- 3 *La tana o corderia dell’Arsenale*, by Antonio Lazzari and Andrea Tosini (1829), 1980
- 4, 5 Postcard with the aerial view of *La Strada Novissima*, 1980
- 6 Entranceway, *La Presenza del Passato*, Aldo Rossi, 1980
- 7, 11 Tender for the realisation of *La Strada Novissima*, s.d.
- 8 Perspective view of *La Strada Novissima*, 1980
- 9 Letter from Roberto Venturi, 18 April 1980
- 10 Design of the facade by Venturi Rauch & Scott Brown
- 12 *Biennale: memoria e provocazione*  
La Stampa, 31 July 1980, Paolo Barbaro
- 13 **Ipad**  
*La presenza del passato: Biennale Architettura 1980*, Rai Teche, 1980
- 14, 16 Collage of Hans Hollein’s facade project, 1980
- 15 Drawing of the facade by Franco Purini and Laura Thermes
- 17 Invitation letter from Giuseppe Galasso to Massimo Scolari, 1980
- 18 Drawing of the facade by Massimo Scolari
- 19 Letter from Arata Isozaki to Paolo Portoghesi, 9 July 1980
- 20, 21 Drawings of the facade by Arata Isozaki

## 8.2 Aldo Rossi’s *Theatre of the World*, 1979

In July 1979 Paolo Portoghesi invited Aldo Rossi to take part in his exhibition *Venezia e lo spazio scenico* (Venice and Theatrical Space) by designing a theatre that would conjure up the sixteenth-century tradition of spectacular floating installations. Rossi chose the morphological theme of the tower for a space that would not only be floating but enclosed, and would measure up to the historic buildings of the San Marco basin. Consciously built to be temporary, the *Teatro del Mondo* (Theatre of the World) was supported by an easy-to-disassemble frame of steel piping covered in wood, resting on a barge that allowed it to float and be transported on water. Standing around twenty-five metres high, the *Teatro* could accommodate up to 400 people. Two symmetrical flights of stairs rose about two metres over the central space, which was topped by a final zinc-roofed section with a terrace around it. The structure was crowned by a sphere with a triangular flag.

The floating theatre remained moored at the Salute for ten days in November 1979. But it was during its amazing journey through the Marghera fog, from its assembly point in the Fusina shipyards to Punta della Dogana, that *Teatro del Mondo* was at its most spectacular, even before it housed any performances. Used in 1980 by the Theatre department directed by Maurizio Scaparro for the first edition of the Venice Carnival, in the summer of that same year it was transported by sea to the Dubrovnik Theatre Festival. Probably the most famous temporary work of the twentieth century, *Teatro del Mondo* has lived on in the memories of architects, theatre people and artists. MCC

- 1, 2 Preparatory drawing for the *Theatre of the World*, Aldo Rossi, s.d.
- 3 Text by Aldo Rossi from the catalogue of the *Venezia e lo spazio scenico* exhibition, 1979
- 4 *The Theatre of the World* on the Canal Grande, 1979
- 5 *The Theatre of the World* at Punta della Dogana, 1979-1980.  
Photo Interpress Photo
- 6 **Ipad**  
*Theatre of the World*, 1979  
Images of the Theatre of the World and interview to Maurizio Scaparro, TG3 Veneto, 1979

- 7 Maurizio Scaparro inside the Theatre of the World, Carnevale del Teatro, 1980. Photo Interpress Photo
- 8 The *Theatre of the World* at Punta della Dogana, 1979-1980
- 9 Carlo Ripa di Meana inside the Theatre of the World, *Carnevale del Teatro*, 1980. Photo Interpress Photo
- 10 Press release of the *Venezia e lo spazio scenico* exhibition, 26 October 1979
- 11 Meeting, the *Theatre of the World* at Dubrovnik, 1980
- 12, 15 Text about the Theatre of the World, s.d.
- 13 *Venezia Teatro del Mondo*  
L'Avanti!, 14-15 October 1979, Paolo Portoghesi
- 14 The *Theatre of the World* at Punta della Dogana, 1979-1980.  
Photo Antonio Martinelli
- 15 The *Theatre of the World* seen from the Riva degli Schiavoni, s.d.  
Photo Antonio Martinelli
- 16 *Un galleggiante senza destino*  
Il Gazzettino, 28 November 1979
- 17 The *Theatre of the World* at Rovigno, 1980. Photo Piero Casadei
- 18 The *Theatre of the World* in Venice, 1980. Photo Piero Casadei
- 19 Press release with notes about the Theatre of the World, s.d

## Panel

Poster of *La presenza del passato* exhibition, 1980

## 0.3A *Aperto 80*, curated by Achille Bonito Oliva and Harald Szeemann

1980 marked the first edition of *Aperto* (Open), the Biennale's new section for young artists, which continued until 1993. It was curated by Achille Bonito Oliva, who was already on the Visual Arts Commission for the International Exhibition that year, together with Harald Szeemann, the famous Swiss curator who had already worked with the Biennale in 1975, bringing *The Bachelor Machines* to the same Magazzini del Sale industrial space on the Fondamenta delle Zattere. While the International Exhibition *L'arte degli anni '70* (The Art of the 1970s) focused on work of the previous decade, *Aperto 80*, as it was later called, brought together the most recent trends in art. This exhibition showed a return to painting after the upheavals of the 1970s and the waves of conceptual, performance and interdisciplinary work. The exhibiting artists included those later known as the Transavanguardia Italiana (Italian Transavantgarde) group championed by Bonito Oliva, with Sandro Chia, Francesco Clemente, Enzo Cucchi, Nicola De Maria and Mimmo Paladino, but also young international artists like Jonathan Borofsky, Tony Cragg, Ulrike Ottinger, Susan Rothenberg, Julian Schnabel and Joe Zucker. *Aperto* registered and absorbed new impulses of the 1980s much like those found in the first Biennale Architettura that same year; it marked the birth of a postmodern sensibility that transcended the rules of modernism and the great ideological narratives of the twentieth century, rekindling an interest in history, eclecticism and the joys of the ephemeral. CA

- 1 Letter from Flavio Caroli to Luigi Carluccio, 17 September 1979
  - 2 Verbal of the Visual Arts Commission's works, 12 – 13 January 1980
  - 3 General program of the 39th International Art Exhibition, 1980
  - 4 Section specification, program of the 39th International Art Exhibition, 1980
- Invitation letter from Giuseppe Galasso to the artists, 1980

- 5 Extract from the report, Mostra Internazionale dei Giovani, 1980
- Extract from the press kit, Magazzini del Sale section, 1980
- 6 *Intervista con Harald Szeemann*  
Flash Art, summer 1980
- 7 *La Biennale 80 ha detto no a gruppi e dogmi*  
Gazzetta del Popolo, 30 May 1980, Giuseppe Pareschi
- 8 *Ignoranza e cecità - Transavanguardia*  
Corriere della Sera, 1 June 1980, Giovanni Testori
- 9 *Dal funerale al kaos rock*  
Corriere d'Informazione, 4 June 1980, Mario Perazzi
- 10 *Miniguida per Aperto 80*  
Il Giornale, 1 June 1980, Vivianne Di Majo
- 11 *Bear Run II*, Bryan Hunt, 1980
- 12 *La tentazione di Sant'Antonio*, Michael Buthe, 1980
- 13 *Photograph from a press article*  
Corriere della Sera Illustrato, 14 June 1980
- 14 *Musica - occhi*, Nicola De Maria, 1980
- 15 *Installazione*, Jonathan Borofsky, 1980
- 16 *Uno sguardo al ponte dei sospiri*  
Corriere della Sera Illustrato, 14 June 1980, Gillo Dorfles
- 17 *Installazione*, Tony Cragg, 1980
- 18 *Dieci anni di arte compreso il futuro*  
Tuttolibri, 7 June 1980, Mirella Bandini

## 0.3B Maurizio Calvesi

Art historian, academic and curator Maurizio Calvesi was one of Italy's most insightful and influential postwar critics. Having studied under the famous art historians Lionello Venturi and Giulio Carlo Argan, Calvesi worked with La Biennale di Venezia for many years in a range of capacities. In various editions from 1964 to 1977 he sat on both the figurative art commission and on the jury panel. From 1980 to 1982 he was a member of the board of directors. In 1984 and in 1986 he directed the Visual Arts department, where he organised two editions titled *Arte e Arti – Attualità e Storia* (1984) and *Arte e Scienza* (1986) (Art and the Arts – Current Affairs and History and Art and Science) which stood out in particular for their blending of contemporary and historic art. From 1988 to 1997 he returned to the Biennale many times as a jury member and to sit on the expert panel for the centenary exhibition and the panel for the 1995 Italian contribution. His profound knowledge of Italian art, both historic and contemporary, yielded important literature on Baroque art and Caravaggio, Futurism and Alberto Burri. His studies on the art of the 1960s are famous, including *Le due avanguardie: dal Futurismo alla Pop Art and Avanguardia di Massa*, whose title captured many of the “mass avant-garde” transformations taking place within art, culture and social conventions, even within La Biennale, from the 1960s onwards. He imbued his two editions of Biennale Arte with his multifaceted openness to other disciplines like psychology, welcoming cross-pollination from other fields of knowledge and the very latest trends in contemporary art. CA

- 1 Opening, *Scultura-teatro*, Alberto Burri, 1984
- 2 Maurizio Calvesi's portrait, June 1983. Foto-Attualità
- 3 Maurizio Calvesi and Sandro Pertini at the opening of the 41st International Art Exhibition, 1984

- 4 *L'asso piglia tutto*  
Corriere dell'Umbria, 10 July 1984, Massimo Duranti
- 5 Report by Maurizio Calvesi about the 41st International Art Exhibition, 1984

- 5 Brochure for *Piazze di Palmanova: Designing Venice*,  
3rd International Architecture Exhibition, 1985
- 6 Posters for the entrance arches at the *Designing Venice* exhibition, 1985
- 7-9 Layout design for the entrance arches at the  
*Designing Venice* exhibition, Aldo Rossi, 1985
- 10, 15, 16 Visitors at the *Designing Venice* exhibition, 1985
- 11 *Designing Venice* exhibition leaflet, 1985
- 12 The Stone Lions awarded as prizes to the winners of the  
*Designing Venice* exhibition, 1985
- 13, 14 Francesco Cossiga and Paolo Portoghesi visiting the  
*Designing Venice* exhibition, 1985

## 8.4 3rd International Architecture Exhibition, *Designing Venice*, curated by Aldo Rossi, 1985

*Progetto Venezia* (Designing Venice) was the title of the third Biennale Architettura in 1985, with Paolo Portoghesi as artistic director and Aldo Rossi as curator. Both well-established and emerging architects were invited to present innovative ideas and designs that dealt with the issue of fitting the new into the old, of innovative architecture within historic contexts, and of Venice's relationship with its hinterland. The areas focused on for the competition were the centre of Venice – the Accademia bridge, Rialto market, Ca' Venier dei Leoni – and sites around the Veneto region – the piazzas of Badoere, Este, and Palmanova; Villa Farsetti in Santa Maria di Sala; the castles of Romeo and Juliet in Montecchio Maggiore; the fortress in Noale and Prato della Valle in Padua.

An international jury chaired by Rossi and made up of Sandro Benedetti, Gianfranco Caniggia, Claudio D'Amato, Guglielmo De Angelis D'Ossat, Diane Ghirardo, Bernard Huet, Robert Krier, Rafael Moneo, Werner Oechslin and Gino Valle selected the best proposals. The challenges and opportunities of redesigning urban space offered by *Progetto Venezia* inspired a vast number of participants, with 1500 projects coming in from around the world. "Leoni di Pietra" – Stone Lions – were awarded to Robert Venturi, Manuel Pascal Schupp, COPRAT and Franco Purini for the Ponte dell'Accademia; Raimund Abraham, Raimund Fein, Peter Nigst and Giangiacomo D'Ardia for Ca' Venier dei Leoni; Alberto Ferlenga for the piazza in Este; Daniel Liebeskind for the piazza in Palmanova; Laura Foster Nicholson for Villa Farsetti in Santa Maria di Sala, and Maria Grazia Sironi and Peter Eisenman for the castles in Montecchio Maggiore.

In addition to the "Stone Lions", Rossi selected the most significant designs from the remaining projects and created posters with the best drawings from each one. Copies of these posters were printed and used to cover "arches" set along the main avenue leading to the Central Pavilion. This officially brought architecture into the Giardini, for an edition which demonstrated, as Rossi explained at the opening, "the potential for architecture to be exhibited as a craft, a technique, a discipline that has freed itself of the ideological framework which kept it from expressing itself in a range of ways." The 3rd International Architecture Exhibition thus broke with the focus on modernism and postmodernism that had characterised the first two editions.

MCC

- 1 Press release by Aldo Rossi with the programme  
for the Architecture sector, 20 May 1983
- 2 Brochure for the 3rd International Architecture Exhibition,  
*Ca' Venier: Designing Venice*, 1985
- 3 Brochure for *Ponte dell'Accademia: Designing Venice*,  
3rd International Architecture Exhibition, 1985
- 4 Brochure for *Mercato di Rialto: Designing Venice*,  
3rd International Architecture Exhibition, 1985

# ROOM 9

## LA BIENNALE AND THE SOCIETY OF THE SPECTACLE

Right from the very first edition in 1895, the story of La Biennale di Venezia has been full of media scandals, political machinations, moments of prudery, attempts at censorship by the Church, and complaints from critics and the general public: a battle fought in the headlines, on the news, and in press releases, that would characterise many events in its history over the decades.

This room presents a selection of episodes which capture the spectacularisation of culture in an era – especially from the 1960s onwards – when new media burst onto the stage of a nascent globalised society. As channels of communication multiplied and a new international culture emerged, La Biennale became an extraordinarily powerful platform that captured the attention of the entire world, in a dramatic shift from a culture of contemplation to the culture of the event. The situation was made even more complex by artists who deliberately sought out scandal as a liberating way to bring their messages into the global arena, or as a critique of what was described, even at the time, as the “society of the spectacle”.

This room provides an overview of artworks harshly criticised by the Church, such as Jeff Koons’ *Made in Heaven*, where the artist depicted himself in explicit poses with the porn star Cicciolina: a work that was even vandalised. More than a century earlier, at the first Biennale in 1895, Giacomo Grosso exhibited *Il supremo convegno* (The Final Tryst), a large, equally explicit painting which scandalised and annoyed the Church but won the public prize. Animals have also frequently caused a hubbub at the Biennale. In 1972 the Mass Moving collective freed thousands of butterflies in Piazza San Marco, prompting anger from animal rights activists. The Film Festival has been punctuated by controversies and episodes of censorship,

with outside forces intervening in the selection or exclusion of certain films. As with the visual arts, the wrangling was over content considered too explicitly sexual, offensive to the Church, or even politically inopportune. In the 1960s Pier Paolo Pasolini’s *Mamma Roma* and Stanley Kubrick’s *Lolita* caused a stir. In 1966 Gillo Pontecorvo’s *La battaglia di Algeri* won a Golden Lion, but offended the French government with its frank criticism of France’s colonial policies.

One case which received a great deal of media attention was that of Carmelo Bene, artistic director of the 1989 Biennale Teatro; his programme was meant to focus on experimentation rather than the end product, championing a kind of “theatre without the show”. But this never came to pass. In a legendary press conference aired on RAI TV, Carmelo Bene presented his vision through a strange performance that swiftly led to his resignation. CA

## 9.1 Carmelo Bene: *The Impossible Quest*

Carmelo Bene was appointed artistic director of Biennale Teatro in 1988 and chose *La ricerca impossibile: il teatro senza spettacolo* (The Impossible Quest: Theatre without the Show) as the title of his programme. His goal was not to proclaim the futility of theatrical experimentation or salute its demise, but rather to rethink it outside the rules of performance and the constraints of production mechanisms. Any “spectacle”, as the formalised outcome of experimentation, was bound to be a product of the state, whose economic and organisational dictates would necessarily determine the time, mode, and criteria of creativity. It is now interesting to note that, budget disputes with La Biennale aside, Carmelo Bene’s programme was indeed a paradoxically consistent “theatre without the show”. The planned performances – Christopher Marlowe’s Tamburlaine the Great, divided into sections entrusted to different groups or actors, and Pierre Klossowski’s Baphomet – never saw the light of day, remaining merely what Bene had probably intended, i.e. a virtually endless workshop. This can be seen, today, from essays that retrace the buzzing hive of ideas that Carmelo Bene created by bringing together artists and scholars. Its main purpose was to investigate a key concept in his work: the “acting machine”, in which actors essentially gave up their identities and became pieces of machinery, sometimes through the use of audio devices that transformed their voices into a musical rhythm entirely antithetical to the traditional cadence of prose. Moving in this direction, Carmelo Bene’s investigation was meant to sound out the impossible, or what he called the “barbaric”, in an attempt to reconnect with the barbarism that lies at the root of theatre, as a game that transcends codified meaning or language. After many disputes with La Biennale, Bene resigned in February 1990, ushering in a period of disputes and conflicts that seriously challenged the founding principles of Biennale Teatro. But one may have to admit, in hindsight and with a bit of surprise, just how memorable his non-Biennale managed to become, and – to paraphrase something Carmelo Bene used to say about himself – just how present it was in its absence. FB

- 1 Theatrical experimentation in state representation, Carmelo Bene
- 2 *Il ricorso al Tar di Bene - Un atto di idiozia - secondo la DC*  
Il Gazzettino, 12 January 1990
- 3 *Biennale. Ultimatium del Consiglio a Carmelo Bene*  
Il Gazzettino, 27 January 1990, Roberto Pugliese
- 4 *L'unica parte lesa è chi paga le idiozie*  
La Nuova Venezia, 12 January 1990
- 5 *Biennale per Bene: licenziamento in vista?*  
L'Unità, 27 January 1990, Nicola Fano
- 6 *Fino a che punto sopportare il pessimo gusto di Bene?*  
Il Tempo, 12 January 1990
- 7 *Sarà divorzio? Non si sa Bene*  
Il Messaggero, 31 January 1990
- 8 *Bene si è dimesso*  
Il Gazzettino, 4 February 1990, Roberto Pugliese
- 9 *Bene abbandona Venezia, 1990*
- 10 *Il Carmelo furioso*  
Il Giornale, 4 February 1990

- 11 *Il sipario è strappato*  
Il Resto del Carlino, 4 February 1990, Luciano Ferraro
- 12 *Carmelo non va più Bene*  
Il Messaggero, 4 February 1990, Manuela Pivato
- 13 *Carmelo Bene, un insulto continuo*  
Il Gazzettino, 5 February 1990, Roberto Pugliese
- 14 *Pierre Klossowski aveva già anticipato il suo no:  
"Venezia è una violazione costante di se stessa. Chi non mi da ragione sfiora  
l'apologia di reato"*  
La Stampa, 5 February 1990
- 15, 16 *Dopo le dimissioni Bene attacca la Biennale  
Bene contrattacca - Inquisiti siete voi*  
La Nuova Venezia, 5 February 1990
- 17 *Biennale, colpo di scena*  
Il Messaggero, 5 February 1990, Rita Sala
- 18 *Bene: addio alla Biennale - Non accetto il processo*  
Corriere della Sera, 4 February 1990, Claudio Pasqualetto
- 19 *Con Bene abbiamo solo peccato di ottimismo*  
Il Gazzettino, 6 February 1990, Roberto Pugliese
- 20 *Bene non sarà sostituito. La Biennale senza Teatro*  
La Nuova Venezia, 6 February 1990, Enrico Tantucci
- 21 *Mai più opere di Bene*  
Il Messaggero, 10 February 1990, Rita Sala
- 22 *Il gran Carmelo della discordia*  
La Nuova Venezia, 27 February 1990
- 23 *Biennale contro Bene - Deve pagare i danni*  
La Repubblica, 24 February 1990
- 24 *Bene: la Biennale non ha soldi...Perché restare?*  
Il Gazzettino, 25 February 1990
- 25 *Non si abbandona una nave che affonda*  
Il Messaggero, 25 February 1990, Rita Sala
- 26 *Biennale. Ventimiglia dalla parte di Bene*  
Il Gazzettino, 27 February 1990
- 27 *Bene come Ronconi dopo quindici anni la storia si ripete*  
La Nuova Venezia, 27 February 1990, Dario Ventimiglia
- 28 *Il Consiglio della Biennale accetta le dimissioni di Bene*  
Il Messaggero, 8 February 1990

### Monitor

Carmelo Bene presents his programme to  
La Biennale's Board of Directors, 1989

Carmelo Bene's press conference at the Hotel des Bains, 1989

Carmelo Bene meets the audience and students at Santa Marta  
Iuav University's venue, 1989

## 9.2 James Lee Byars, *Holy Ghost*, 1975

James Lee Byars (1932-1997) was an American artist specialised in sculpture, installations and performances filled with conceptual, mystical power. In 1972 he was invited by Harald Szeemann to Documenta 5 in Kassel, where he stood on the threshold of the Fridericianum Museum for the entire vernissage, his back turned to visitors, with one foot inside the exhibition and one foot outside of it. He and Szeemann struck up a friendship, and in 1975 the curator invited him to present a performance to inaugurate *The Bachelor Machines* in Venice. At 4.30 pm on Saturday, 6 September, an immense human-shaped piece of white canvas, sixty metres long and forty metres wide, was unrolled in Piazza San Marco. Wearing a black top hat and dressed entirely in gold, the artist directed the effort to position this huge cutout, which viewers enthusiastically lifted up bit by bit and moved around for several minutes. In the end, Lee Byars gathered all the material into a black bag that was carried by boat to the Magazzini del Sale and returned to the entrance of *The Bachelor Machines*. This

performance's provocative title was *James Lee Byars Does the Holy Ghost*, suggesting religious connotations perhaps inspired by the chosen location in front of the basilica. Whilst the event was welcomed and enjoyed by those in Piazza San Marco, the newspaper reviews were extremely sarcastic, calling the work a "doll", "sheet" or "ghost". VP

### Blow-up

*Holy Ghost*, James Lee Byars, Piazza San Marco, 1975.  
Photo Lorenzo Capellini

- 1, 5, 7-13 James Lee Byars, note on the instructions sent to Franco Raggi for the performance *Holy Ghost*, 1975
  - 2, 3 James Lee Byars, projects for the performance *Holy Ghost*, 1975
  - 4 Letter from Floris Luigi Ammannati to Ditta Broggi Luigi, 25 August 1975
  - 6 List with the instructions for the realization of *Holy Ghost*, 1975
  - 14, 15, 17, 18 *Holy Ghost*, James Lee Byars, Piazza San Marco, 1975.  
Photo Lorenzo Capellini
  - 16 *Holy Ghost*, James Lee Byars, Piazza San Marco, 1975.  
Photo Antonio Martinelli
  - 19 *Happening a San Marco*  
Il Gazzettino, 7 September 1975
  - 20 *Happening a San Marco*  
Il Gazzettino, 7 September 1975
- Maquette** for the performance *Holy Ghost* in Piazza San Marco, 1975  
red tissue paper, 280x180 cm

## 9.3A Giacomo Grosso, *The Final Tryst*, 1895

At the first edition of Biennale Arte in 1895, a scandal erupted around one of Giacomo Grosso's paintings. The work depicted a man in a coffin, with five nude female figures draping themselves over the dead body in lascivious poses. It caused such an uproar that the Patriarch of Venice, Giuseppe Sarto (the future Pope Pius X), refused to visit the exhibition and wrote to the Biennale's founder, Mayor Riccardo Selvatico, telling him it had to be removed. The painting was exhibited nonetheless, and in amidst all the controversy it even won the public prize, though Selvatico lost the city elections to a moderate Catholic coalition supported by the Venetian curia. An investment company then bought the painting with the intention of taking it on tour around America, but it ended up being accidentally destroyed in a fire. CA

- 1, 2 *The Final Tryst*, Giacomo Grosso, 1895
- 3 Room D, *The Final Tryst*, Giacomo Grosso, 1895
- 4 *Uno scandalo alla Biennale*  
Il Gazzettino, 11 November 1962, Paolo Rizzi
- 5 *Il Patriarca contro il Sindaco alla Biennale di Venezia del 1895*  
Il Paese, 4 February 1950, Federico Fontanella
- 6 Telegram from Giacomo Grosso to Antonio Fradeletto, 28 September 1895
- 7 King Umberto and Queen Margherita inaugurating the 1st International Art Exhibition of the city of Venice, 1895. Photo Studio Giacomelli
- 8 *Indiscrezion. Un'ociada a le sale*  
Tonin Bonagrazia, 21 April 1895
- 9 *Famosa disputa su un quadro che non esiste più*  
Piccola, 1 July 1930, Angelo Todri
- 10 *Il supremo convegno*  
Tonin Bonagrazia, 12 May 1895
- 11 Cardinale Giuseppe Sarto's correspondence and text extracted from *60 anni della Biennale di Venezia*, Romolo Bazzoni, 1962

## 9.3A Jeff Koons, *Made in Heaven*, 1990

Jeff Koons took part in *Aperto 90*, the young art section of the 44th International Art Exhibition at the Corderie, curated by Renato Barilli, Bernard Blistène, Jacob Wenzel, Stuart Morgan, and Linda Shearer. On this occasion Koons presented *Made in Heaven*, a series of paintings and a sculpture celebrating his romantic relationship with Cicciolina, a Hungarian-born porn actress who was then in the Italian Parliament. The painting's explicitly sexual content scandalised the Italian press, which attacked it in the name of decency and morality; meanwhile, Karl Lagerfeld immortalised the couple in an amorous embrace at Hotel Danieli for *Vogue America*. The work remained on view despite demands that it be removed, but some of the paintings were vandalised on 3 September 1990. CA

- 1 Invitation letter from Giovanni Carandente to Jeff Koons, 27 January 1990
- 2 *Jeff e Ilona (Made in Heaven)*, by Jeff Koons, 1990. Photo Giorgio Zucchiatti
- 3 Plan of the exhibition space for Jeff Koons's artwork at the Corderie dell'Arsenale, 1990
- 4 **Ipad**  
Jeff Koons's scarred canvas at La Biennale 1990, RAI
- 5 *Cicciolina nuda alla Biennale*  
La Stampa, 24 May 1990, Claudio Altarocca
- 6, 7 Jeff Koons and Ilona Staller before the artwork *Jeff e Ilona (Made in Heaven)*, 1990.  
Photo Giorgio Zucchiatti
- 8 *Cicciolina alla Biennale*  
Il Secolo XIX, 24 May 1990, Francesca Pasini
- 9 Letter from Giovanni Carandente to Linda Shearer, 2 September 1990
- 10 Note for Raffaello Martelli, 2 September 1990
- 11 Fax from Ann D. Rickey to Giovanni Carandente, 4 September 1990
- 12 Fax from Gary McCraw to Giovanni Carandente, 12 September 1990
- 13 Fax from Gary McCraw to Giovanni Carandente with notes, 12 September 1990
- 14 Fax from Stefano Basilico to Antonio Zanchet, 2 October 1990
- 15 *Koons Crazy*, *Vogue*, August 1990

## 9.3A Gran Fury, *Untitled (Pope Piece)*, 1990

At the very same edition of *Aperto* where Jeff Koons' work caused such a stir, another American installation brought an angry response from the church. It was a work by Gran Fury, a New York collective of artists and activists campaigning for the rights of AIDS victims. In the Corderie spaces the group presented two large posters, one with a picture of John Paul II alongside a text denouncing the Catholic Church's attitude to the AIDS epidemic, the other a phallus surrounded by slogans encouraging the use of condoms. After protests and open condemnation by the Vatican and the general public, the artistic director of the Visual Arts department, Giovanni Carandente, considered removing the work, but ultimately stayed true to the integrity of La Biennale and the principles of free expression that have always inspired it. CA



1 *Biennale, l'arte dello scandalo*  
La Repubblica, 26 May 1990, Cecchetti

2 *Scandalo alla Biennale*  
La Stampa, 26 May 1990, Mario Lollo

3-5, 7 *Untitled*, Gran Fury, 1990. Photo Giorgio Zucchiatti

6 *Il Patriarca: è un insulto*  
La Nazione, 26 May 1990, Luciano Ferraro

### 9.3A Gino De Dominicis, *Second Solution of Immortality: The Universe Is Immobile, 1972*

Gino De Dominicis was one most prolific young Italian artists of the time, and his work was exhibited in various editions of Biennale Arte. The first occasion was in 1972, at the 36th International Art Exhibition, when Renato Barilli invited him to take part in the exhibition *Opera o comportamento* (Work or Behaviour) which the Bologna-based critic was curating with Francesco Arcangeli. The piece presented by De Dominicis caused an enormous stir. It was a installation comprised of various conceptual works created in previous years: *Cubo invisibile* (Invisible Cube, 1967), *Palla di gomma (caduta da 2 metri) nell'attimo immediatamente precedente il rimbalzo* (Rubber ball [dropped from a height of 2 meters] in the moment just before bouncing, 1968-69) e *Attesa di un casuale movimento molecolare generale in una sola direzione, tale da generare un movimento spontaneo della pietra* (Waiting for a random, general molecular movement in one direction to generate a spontaneous movement of the stone, 1969) which had already been shown at Fabio Sargentini's L'Attico gallery in 1969. On 9 June, for the opening, De Dominicis added another element to this work: Paolo Rosa, a young man with Down syndrome, who sat there in a corner contemplating the works laid out in front of him. Although this tableau vivant remained on view only for a few hours – the young man was soon replaced by a little girl sitting in the same seat with the same caption (“Second Solution of Immortality”) – it triggered extremely indignant reactions from critics and intellectuals, including Pier Paolo Pasolini and even Eugenio Montale, who mentioned the event in his Nobel acceptance speech. The outrage made it all the way to Parliament, and charges were brought against De Dominicis for “abduction of an incapacitated person”. CA

1 *L'uomo non è un rottame da esporre alle mostre pop*  
Gazzetta di Parma, 10 June 1972

2 Letter from Dr. Antonio Mavilla to Gino De Dominicis and Mario Penelope,  
2 June 1972

3 *La bambina dopo il minorato*  
Il Giorno, 13 June 1972, Marco Valsecchi

4 Telegram from the female delegates of the Democrazia Cristiana  
women's movement to La Biennale, 9 June 1972

5 *Seconda soluzione di immortalità (l'universo è immobile)*, by Gino De Dominicis,  
1972. Photo Reporter

6 Telegram from the Gruppo spontaneo handicappati to La Biennale,  
9 June 1972

7 Letter from the Comitato Unitario invalidi di Firenze, 10 June 1972

8 *Perché ho esposto un uomo*  
Epoca, 18 June 1972, Liana Bortolon

9 *Il mongoloide alla Biennale è il prodotto della sottocultura*  
Tempo, 25 June 1972, Pier Paolo Pasolini

10 *Biennale vergogna*  
Fiera Letteraria, 18 June 1972

11 *Arte bestiale*  
Lo Specchio, 18 June 1972

### 9.3B Scandals, controversies and censorship at the Film Festival

The postwar history of the Venice International Film Festival is punctuated by controversies and attempts at censorship; it points to an evolution, over the years, in the way viewers, society and institutions reacted to films considered offensive to public decency and religion, or which irritated political leaders. The most glaring example of this was Gillo Pontecorvo's 1966 film *La battaglia di Algeri* (The Battle of Algiers), which won a Golden Lion. The French delegation walked out of the theatre and left the Lido, deeming the film an attack on its government's colonial policies. Georges Sadoul, one of the leading film historians of the time, wrote: “France just lost the Battle of Algiers for the second time”. Another serious episode of interference was when Clare Boothe Luce, the US ambassador, succeeded in having Richard Brooks' film *Blackboard Jungle* taken off the programme on the grounds that it was “degenerate” and gave a counterproductive image of the United States. This interference had considerable support back home: director Joseph Mankiewicz sympathised with the ambassador, writing that European festivals were a platform for the intellectual arrogance of those who denigrated American institutions and society. Ottavio Croze, the festival director, did as he was told and replaced the film with Curtis Bernhardt's *Interrupted Melody*. In 1956, *Calle Mayor* by Juan Antonio Bardem, an opponent of the Spanish regime, prompted the intervention of General Franco himself, but this time the new artistic director, Floris Luigi Ammannati, stood his ground and the movie was screened.

Other controversies accompanied films such as Luigi Zampa's *La romana* (1954), Louis Malle's *Les Amants* (1958), Pier Paolo Pasolini's *Mamma Roma* (1961) and Stanley Kubrick's *Lolita* (1962). In 1962 Joseph Losey's *Eva* was withdrawn by the producers, after the festival had already announced it would be in the competition, and 1963 brought a standoff between Motion Picture Associated, which wanted Robert Rossen's *Lilith* to be in the running, and Luigi Chiarini, who successfully kept it out. In 1966 the scandalous film was Mai Zetterling's *Nattlek*: Cardinal Urbani, Patriarch of Venice, attacked it as “contrary to sound moral principles”, resulting in a screening where only journalists were admitted. Accusations of offending religious sensibilities were levied at Ken Russell's *The Devils* (1971), which the critic Father Claudio Sorigi defined “intolerably blasphemous in every way”, and Martin Scorsese's *The Last Temptation of Christ* (1988), which sparked protests in front of the Palazzo del Cinema and legal charges against La Biennale. GG

1, 3, 6 *La battaglia di Algeri* by Gillo Pontecorvo, 1966

2 **Ipad**  
*La battaglia di Algeri* by Gillo Pontecorvo, 1966

4 *Ancora Censura - Taccuino indiscreto del Festival di Venezia*  
Corriere d'informazione, 1/2 September 1966

- 5 *I francesi hanno disertato la Mostra*  
Momento Sera, 1/2 September 1966
- 7 *Il direttore della Mostra ha violato il regolamento?*  
Giornale d'Italia, 20-21 August 1966
- 8 *Dure critiche svedesi ai dirigenti del Festival*  
La Notte, 20 August 1966
- 9 *È necessario garantire l'autonomia della Mostra, Avanti!*, 23 August 1966
- 10, 11 *Natt lek* by Mai Zetterling, 1966
- 12 *Scandalizzati dai Diavoli i cattolici accusano Rondi*, La Stampa sera, 30 August 1971, Piero Perona
- 13 *I diavoli deplorato dal Patriarca Luciani*, Il Mattino, Napoli, 1 September 1971
- 14, 18 *The Devils* by Ken Russel, 1971
- 15 *I vescovi condannano "Teorema". Un magistrato romano lo sequestra*  
La Voce Repubblicana, 15 September 1968
- 16 *Laura Betti su sequestro Teorema*, ADNKRONOS, 13 September 1968
- 17 *Teorema* by Pier Paolo Pasolini, 1968
- 19 Telegram from Ilona Staller, 5 September 1988
- 20 *Una violenza come mai era stata vista sullo schermo*, Corriere del Giorno, 29 August 1971
- 21 *I Giudici della Procura della Repubblica di Venezia hanno manifestato l'intenzione di visionare il film L'ultima tentazione di Cristo*  
Notizie ansa, 18 August 1988
- 22 Sentence against Martin Scorsese and Paolo Portoghesi, 8 October 1988
- 23 *The Last Temptation of Christ* by Martin Scorsese, 1988

## Monitor

Clips from the following films:

*La romana* by Luigi Zampa, 1954

*Lolita* by Stanley Kubrick, 1962

*Mamma Roma* by Pier Paolo Pasolini, 1962

*The Devils* by Ken Russel, 1971

*Eva* by Joseph Losey, 1962

*Belle de jour* by Luis Buñuel, 1967

*Les Amants* by Louis Malle, 1958

*Lilith* by Robert Rossen, 1964

*Teorema* by Pier Paolo Pasolini, 1968

*The Last Temptation of Christ* by Martin Scorsese, 1988

## 9.4 Nicolás García Urriburu, *Actions in Nature*, 1968

Argentine artist Nicolás García Urriburu came to Venice in June 1968 just as major student protests were erupting around the opening of the 34th International Art Exhibition, to which Urriburu had not been officially invited. At 8 am on 19 June, Urriburu convinced a gondolier to take him out along the Grand Canal into which he poured thirty kilos of a non-toxic fluorescent substance that turned the water bright green for many hours. This surreal spectacle left the city frightened and confused, but news soon spread that it was just another action by a contemporary artist who wanted to raise awareness of environmental issues. Urriburu's work with images documenting this gesture was then officially exhibited at Biennale Arte 2017, showing him to be a pioneer of environmental art. CA

*Action dans la nature* di Nicolás García Urriburu, mute and colour version, 1968, Tate Modern

## 9.4 Mass Moving, *Biological Liberation of 10,000 Butterflies in Piazza San Marco, Venice*, 1972

The Belgian Mass Moving Project collective installed a large white sculpture in the shape of a giant cocoon at Piazza San Marco, containing 10,000 pupae of live white butterflies. On 11 June 1972 the cloth that had covered the sculpture until the day of the opening was removed and the hatched butterflies invaded the square and the rest of the city; this prompted furious reactions from animal rights activists and local groups, who pointed out the risk of damage to the lagoon ecosystem. CA

- 1, 2 Mass Moving Project: Biological Liberation of 10.000 butterflies, 1972.  
Photo Studio Giacomelli
- 3 Mass Moving Project: butterfly, 1972
- 4 *La vignetta di Mosca*  
Corriere d'Informazione, 12 June 1972
- 5 *E sarebbe un artista?*  
Il Resto del Carlino, 10 June 1972, Enzo Tortora
- 6 Happening *Progetto Mass Moving*, Piazza San Marco, 1972.  
Photo Cameraphoto Modena
- 7 *Uno svolazzo di morte che si deve evitare*  
Il Giorno, 30 May 1972, Enzo Lucchi

## 9.4 Antonio Paradiso, *Bull and Mechanical Cow*, 1978

For Biennale Arte 1978, which focused on the relationship between art and nature, Antonio Paradiso installed an enclosure containing a mechanical cow – a device generally used for artificial insemination on cattle farms – in the space in front of the Belgian pavilion. The artist then brought a massive living bull named Pinco to the Giardini; Pinco's resulting encounter with the mechanical cow prompted considerable perplexity and shock, not to mention disapproval from the pope. CA

- 8 *Bull and Mechanical Cow*, by Antonio Paradiso, 1978
- 9 *Performance di toro contestata alla mostra Biennale di Venezia*  
Corriere della Sera, 1 July 1978
- 10 *Tu non lo sai ma Pingo è sporaccione*  
Il Diario, 1 July 1978
- 11 Letter from Carlo Ripa di Meana to Antonio Paradiso, 11 May 1978
- 12 Antonio Paradiso's note about the artwork *Toro e mucca meccanica*
- 13, 14 *Bull and Mechanical Cow*, Antonio Paradiso, 1978
- 15 *Sì, anche il toro Pingo è libertà di espressione*  
La Repubblica, 2-3 July 1978, Roberto Bianchin

## 9.5 Pina Bausch in Venice, 1985

Pina Bausch (1940-2009) is a legendary name in contemporary dance. This Polish-German dancer trained at the Folkwangschule in Essen under the direction of Kurt Jooss, an anti-Nazi choreographer best known for his parable *The Green Table*, in which the rulers of the world gamble with the fates of nations on the battlefield. In 1960 Bausch began studying at Juilliard in New York City, where she met many eminent figures in American dance. On her

return to Germany she joined Jooss' Volkswang-Ballett and successfully turned her hand to choreography, ultimately directing her own Tanztheater group at Schauspielhaus in Wuppertal from 1973 to 1974. Her direction was criticised by ballet lovers, however, since traditionalists disliked the prosaic realism of her touching pieces, which were meant to be experienced empathically rather than understood intellectually. But she triumphed at the Festival Mondial du Théâtre de Nancy in 1977 and earned the admiration of Federico Fellini, who asked her to play the Countess in his 1983 film *E la nave va*. In 1985 Franco Quadri's Biennale Teatro dedicated a solo event to the choreographer and director, with eight amazing works: *Frühlingeoper* (1975), *Die sieben Todsünden* (1976), *Blaubart* (1977), *Café Müller* (1978), *Kontakthof* (1978), *1980, ein Stück von Pina Bausch* and *Bandoneon* (1980), and *Auf dem Gebirge* (1984). Her dancer-actors – people, not characters, with a tragicomic malaise that anyone can relate to – became the vectors for an enduring, pervasive “Bauschian infiltration” of Italian and European dance. EGV

- 1 Poster of *Antologia Pina Bausch*, Tanztheater Wuppertal  
Artistic direction Pina Bausch, 14 May-15 June 1985
- 2 *Blaubart* from the publication *Il Teatro di Pina Bausch*,  
Lionetta Bentivoglio, Ubulibri, 1985
- 3, 4 *Café Müller*, Pina Bausch, 1985
- 5 *Sagra della primavera/Sacre du printemps*, Pina Bausch, 1985
- 6 ‘Sulla montagna...’ *Grida dalla memoria di Pina Bausch*  
Il Manifesto, 1 June 1985, Gianni Manzella
- 7 *Auf dem gebirge hat man ein geschrei gehört*, Pina Bausch, 1985
- 8 *Uno spettacolo di Pina Bausch/Ein Stück*, Pina Bausch 1985
- 9 *Bandoneon*, Pina Bausch, 1985
- 10 *Kontakthof*, Pina Bausch, 1985
- 11 *Ma è davvero tanto triste quel sentimento chiamato tango?*  
La Repubblica, 7 June 1985, Leonetta Bentivoglio
- 12 *Il tango interiore di Pina Bausch*  
Il Manifesto, 8 June 1985, Gianni Manzella
- 13 *I sette peccati capitali/Die sieben Todsünden*, Pina Bausch, 1985
- 14 *Pallido tango argentino*  
L'Unità, 7 June 1985, Marinella Guatterini
- 15 *L'autorappresentazione di Pina Bausch*, Franco Quadri, 1985

# GIARDINO SCARPA

## TAN DUN, TRADITIONAL MUSIC AND TECHNOLOGY

From 1966 to 1976, China was gripped by the Cultural Revolution that Mao orchestrated at the end of his rule. With the Communist regime's repression of criticism and dissent (intellectuals being relegated to the lowest rung on the social ladder, the "stinking ninth category"), music, too, found itself in the censor's crosshairs: not only contemporary, modernist and avant-garde music, but also the cultured Western tradition, considered a deleterious product of Europe. It was only in the late 1970s, in the wake of Mao's death and the accusations brought against the so-called Gang of Four for the persecution and horrors of the Cultural Revolution, that Western classical music was once again cultivated and studied in Communist China. Tan Dun is emblematic of this process (1957). Born and raised in a small village in Hunan, a mountainous province in Southern China, Tan Dun assimilated its ancient shamanistic culture from an early age. He developed a passion for music, despite being sent to work in the rice paddies at the age of fifteen; it was only in 1978, when the Beijing Conservatory reopened and he was one of the first to enrol, that he came into contact with Western music. This was the starting point for the career of a composer who is one of the best examples of Eastern creativity being wedded and interwoven with the Western modern and contemporary tradition. His rediscovery of traditional Chinese culture and its deep spiritual roots made him so unpopular with the Communist regime that in 1986, immediately after his piece *On Taoism* (1985) brought him to the international limelight, Tan Dun decided to move to the United States. One perfect illustration of his melding of East and West is the opera *Marco Polo* (1995). Ritual shamanistic music has retained an essential role in Tan Dun's artistic vision and compositional technique; his holistic ideal of a musical symbiosis with the environment is expressed in compositions where natural elements like water, stone, paper, and ceramics interact with classic orchestral instruments. On the other hand, technology has also

played a decisive role in his work. A one-of-a-kind figure on the international scene, Tan Dun is one of just a handful of composers to have become a popular phenomenon, with fifteen million views on YouTube for his *Internet Symphony* (2009). Tan Dun won a Golden Lion at the Biennale Musica in 2017. *Buddha Passion* (2018) is a monumental oratorio in six acts for seven solo voices, choir and orchestra. For the very first time, it interweaves stories that have held a key place in Eastern cultures for thousands of years with the Passion tradition of Christian music. Inspired by the majestic Mogao Grottoes in Dunhuang, its subject is Buddha's teachings and the universal concepts of love, forgiveness, sacrifice and salvation. CF

### Music excerpts

Music excerpt *Concerto for Orchestra* (Da Marco Polo), Tan Dun, 2012

Music excerpt *Passacaglia: Secrets of Wind and Birds*, Tan Dun, 2015

Music excerpt *Percussion Concerto: The Tears of Nature*, Tan Dun, 2012

# ROOM 12

## THE 1990S: FROM NATION STATES TO A GLOBAL BIENNALE

This room focuses on transformations in the concept of national identity and the idea of the nation state, which played a key role in the European history and of La Biennale di Venezia for many years. The 1990s brought epoch-making changes that upset the entire global balance of power. This was the decade which followed the fall of the Berlin Wall and the end of the Cold War, the end of the standoff between the great Western and Soviet blocs and the emergence of a new borderless European community. It was also a decade of crisis for the nation state, a founding concept for the Biennale: the exhibition model presented at the Venetian institution was an outgrowth of the nineteenth-century world's fairs that trumpeted the power of colonial empires. Representing national identity through pavilions was another highly symbolic demonstration of the power that nation states attempted to exert in the twentieth century. This room offers an overview of the history of the Giardini di Castello's national pavilions, which mirrored twentieth-century geopolitical dynamics through changes to their architecture, starting with the first pavilion built in 1907, that of Belgium.

In the 1990s, La Biennale reflected the crisis of the nation state model that had played such a leading role in nineteenth and twentieth-century history. In an extraordinarily clear visual summary, the 1993 Biennale Arte illustrated the collapse of twentieth-century national identity, with three national pavilions bearing witness to the end of the great powers that had emerged at the end of World War Two, implying new frameworks and cultural transformations.

1998 was a year of major transformations: La Biennale was converted from a public body into a legal entity governed by private law, acquiring greater autonomy and flexibility. That same year Paolo Baratta was appointed president and ushered in significant changes: new exhibition spaces at Arsenale; new specific areas and auditoriums for dance, music and theatre events; a single curator appointed by La

Biennale and responsible for the International Art Exhibition; an increase in participating countries, with national pavilions in the historic centre or at new Arsenale sites. 1999 was the year of the first Biennale Danza with Carolyn Carlson as artistic director, with the opening edition focusing on women and water. That same year, Paolo Baratta appointed the famous Swiss curator Harald Szeemann to direct the Visual Arts department; he organised *dAPERTutto – APERTO over ALL – APERTO par TOUT – APERTO über ALL*, an innovative, visionary exhibition which that expanded La Biennale's customary boundaries and shook up its artistic map, bringing in artists from all over the world and paying special attention to a vast army of Chinese artists. La Biennale sensed and celebrated the dawn of a new globalised world where national borders intertwine with international phenomena – as the events of recent months have reminded us, with a remote Chinese city called Wuhan turning out to be much closer to Venice, in every way, than we ever could have imagined. CA

# ROOM 12

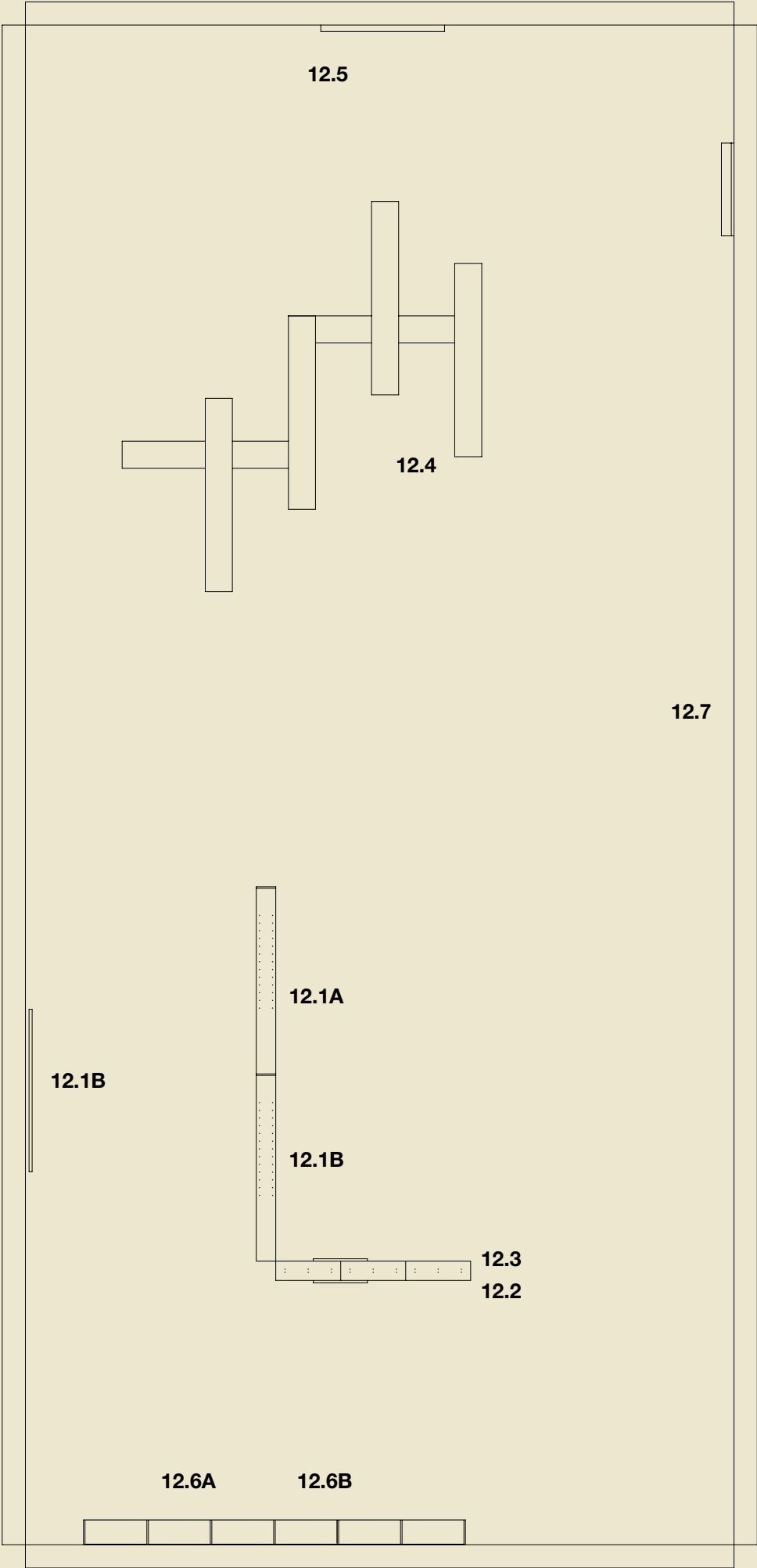

## 12.1A *Aperto 93: Emergenza/Emergency*

*Aperto 93* was the last edition of this famous section devoted to young artists, which was absorbed back into the main Biennale Arte exhibition starting in 1997.

The 45th International Art Exhibition, which should have taken place in 1992, was postponed to 1993, so that the next edition could be held in 1995 to celebrate the Biennale's centenary. In 1993 Achille Bonito Oliva curated an edition titled *Punti cardinali dell'arte* (Art's Cardinal Points) with many exhibitions spread out across the city in various spaces and institutions. Bonito Oliva also oversaw *Aperto*, inviting Helena Kontova to bring together critics, curators and art world figures such as Francesco Bonami, Nicolas Bourriaud, Jeffrey Deitch, Berta Sichel and Matthew Slotover to present the most interesting emerging talents of the moment in the Arsenale spaces. Out of the many curatorial contributions, one should note that of Francesco Bonami, who would become artistic director of Biennale Arte 2003 ten years later. He brought a whole platoon of rising American artists to *Aperto 93*, including Matthew Barney (who won the Premio Europa 2000), Jessica Diamond, Charles Ray, Mexican artist Gabriel Orozco, and Italian artists Rudolf Stingel and Maurizio Cattelan. Other sections featured the work of the very young Kai Althoff, Janine Antoni, John Currin, Sylvie Fleury, Dominique Gonzalez-Foerster, Damien Hirst, Carsten Höller, Philippe Parreno, Pipilotti Rist, Rirkrit Tiravanija, Nari Ward and Andrea Zittel, as well as many others who were to return in later editions of Biennale Arte. CA

- 1 Extract from Achille Bonito Oliva's project, 17 December 1992
- 2 Francesco Bonami's project, 8 April 1993
- 3 Fax from Sylvie Fleury to Helena Kontova, 29 March 1993
- 4 Letter from Matthew Barney to Dario Ventimiglia, 19 July 1993
- 5 Sylvie Fleury's project, 29 March 1993
- 6 *Drawing restraint 7*, Matthew Barney
- 7 Minutes of the jury, awarding of prizes, 1993
- 8 Notes, Pipilotti Rist, 1993
- 9 *Lick and lather*, Janine Antoni, 1993 and *Exodus*, Nari Ward, 1993. Photo Giorgio Zucchiatti
- 10 *Mother-child*, Kiki Smith, 1993. Photo Giorgio Zucchiatti
- 11 Nedko Solakov's project, 14 April 1993
- 12 *A to z breeding unit: for averaging eight breeds*, Andrea Zittel, 1993. Photo Giorgio Zucchiatti
- 13 *Exodus*, Nari Ward, 1993. Photo Giorgio Zucchiatti
- 14 *The world ag ant farm*, Yukinori Yanagi, 1990 and *Golden harmony*, Noboru Tsubaki, 1993. Photo Giorgio Zucchiatti
- 15 Project by Bigert & Bergström, 1993

## 12.1B The national pavilions in 1993: Hans Haacke, Richard Hamilton, Ilya Kabakov

1993 was a watershed year in which the Soviet Union crumbled, the consequences of the fall of the Berlin Wall made themselves felt, and a more general disillusionment with the nation state concept took hold. Many of the artists invited to represent their countries in the Biennale Arte's

national pavilions that year presented complex meditations in which the concept of nationality was not only a theme but almost a means of expression. In the pavilion of the German Federal Republic – representing the reunified nation for the first time – Hans Haacke's *GERMANIA* installation depicted history in ruins, tearing up the floor of the pavilion that had been remodelled in Neoclassical style by the Nazi regime in the 1930s. At the same time, it seemed to envisage a new construction site for rebuilding a reunified country. Alongside the German pavilion, the British pavilion was also worthy of note, with Richard Hamilton's paintings evoking the conflict in Northern Ireland. Following the breakup of the Soviet Union, Russia took part in the Biennale for the first time as the Commonwealth of Independent States. Ilya Kabakov was the first living artist to represent Russia in a solo exhibition. Together with Haacke's ruins, Kabakov's *Red Pavilion* was one of Biennale Arte 1993's most famous installations. Visitors passed through an empty, abandoned Russian pavilion to a new building, a miniature pavilion set up in the garden at the back. Painted a festive pink and red and decorated with Soviet-era symbols like the hammer and sickle and red stars, it wafted solemn music from marches and celebrations of the 1950s as if to remind us that the past is not too far off. Haacke's pavilion won Best National Participation; Richard Hamilton won the International Award for best artist, while Kabakov won a special mention from the jury. CA

### Blow-up

- Germania*, Hans Haacke, 1993. Photo Roman Mensing  
Courtesy Hans Haacke
- 1 Hans Haacke, text published in the catalogue *GERMANIA*, 1993
  - 2 *Germania*, Hans Haacke, 1993. Photo Roman Mensing  
Courtesy Hans Haacke
  - 3 *The citizen*, Richard Hamilton, 1993  
Courtesy Richard Hamilton
  - 4 *The state*, Richard Hamilton, 1993  
Courtesy Richard Hamilton
  - 5 *The subject*, Richard Hamilton, 1993  
Courtesy Richard Hamilton
  - 6-8 Richard Hamilton inside the Great Britain pavilion, 1993  
Courtesy Richard Hamilton
  - 9 Interior of the Great Britain pavilion, 1993. Photo Giorgio Zucchiatti
  - 10 Richard Hamilton, XLV Biennale di Venezia, British pavilion  
13 June - 10 October 1993, The British Council, 1993
  - 11 Letter from Emilia and Ilya Kabakov to Achille Bonito Oliva, 25 February 1993
  - 12 Letter from Emilia and Ilya Kabakov to Achille Bonito Oliva, 18 April 1993
  - 13 Letter from Achille Bonito Oliva to Ilya and Emilia Kabakov  
and to Vladimir Tarasov, 26 February 1993
  - 14 Letter from Achille Bonito Oliva to Tarasov Vladimir Petrovich, 19 April 1993
  - 15 Letter from Emilia and Ilya Kabakov to Achille Bonito Oliva, 23 March 1993
  - 16 Letter from the Ministry of Foreign Affairs with a list of the former  
Soviet Union's countries recognized by the Italian government, 3 July 1993
  - 17 *The Red Pavillon*, Ilya Kabakov, 1993
  - 18-20 Russian pavilion brochure, 1993
  - 21, 22 Project for the Russian pavilion, 1993

## 12.2 Jean Clair, *Identity and Alterity: Figures of the Body 1895/1995, 1995*

In 1995 La Biennale di Venezia celebrated its centenary. For this special edition Jean Clair was invited to serve as the artistic director of the Visual Arts department, the first time a non-Italian had occupied this role in the Venetian institution's hundred-year history. Jean Clair had risen to prominence in the 1980s at the Centre Pompidou, with a series of important exhibitions, and had headed the Picasso Museum in Paris since 1989. His first encounter with the Biennale came at a very young age when, in 1975, he edited the catalogue of Harald Szeemann's legendary exhibition *The Bachelor Machines*. Known for his monographic shows of the work of Marcel Duchamp, Alberto Giacometti and Balthus, but also for innovative thematic ones such as *L'âme au corps* and *Les Réalismes*, in Venice Jean Clair curated a vast exhibition titled *Identità Alterità. Figure del corpo* (Identity and Alterity: Figures of the Body 1895/1995), which traced changes in the way the human figure was depicted over the twentieth century. The exhibition was held at Palazzo Grassi (to ensure the climate control required to secure the loan of certain works), Museo Correr and the Giardini's Central Pavilion. This last site also housed the exhibition *Impronte del corpo e della mente* (Impressions of the Body and Mind), curated by Adalgisa Lugli. Some Italian critics expressed disappointment that Clair's exhibition did not explicitly celebrate La Biennale history. Further complaints arose over the cancellation of "Aperto", the section for young artists, which resulted in a Biennale more centred on the past than the future. Despite all the criticism, *Identità Alterità* stood out from all previous editions in that it was less concerned with contemporary artistic innovations and more.

### Panel

Poster of the *Identity and Alterity. Figures of the Body 1895/1995* exhibition, 1995

- 1 Synopsis of the 46th International Art Exhibition *Identity and Alterity*, 1995
- 2 *Relief Portrait of Arman*, Yves Klein, 1993
- 3 Letter from Jean Clair to Paolo Viti, 3 October 1995
- 4 *Jean Clair: Addio a Venezia ingrata*  
Corriere della Sera, 12 November 1995, Sebastiano Grasso
- 5 *Ho portato 320 mila visitatori e miliardi. L'assessore fuccia da solo, io me ne vado*  
Corriere della Sera, 12 November 1995
- 6 Jean Clair at the opening of the 46th International Art Exhibition, 1995
- 7 *Femme de Venise*, Alberto Giacometti, 1995
- 8 Francis Bacon, 1995
- 9 Giorgio de Chirico, 1995
- 10 Georg Baselitz, 1995
- 11 Marcel Gromaire and Otto Dix, 1995

## 12.3 Marina Abramović, *Balkan Baroque, 1997*

The 47th International Art Exhibition took place in a climate of uncertainty within the institution, which led to the adoption of a new statute the following year, in 1998. The artistic director of the Visual Arts department was Germano Celant, the famous curator and art historian

who was back at the Biennale after his 1976 exhibition in the Central Pavilion, *Ambiente/Arte* (Environment / Art). In 1997, with just a few months to prepare, Celant put together *Futuro Presente Passato* (Future Present Past). This exhibition did away with previous distinctions between the traditional section and *Aperto*, presenting a one-of-a-kind showcase combining work by three generations of artists active from the 1960s to the end of the 1990s. Serbian artist Marina Abramović's *Balkan Baroque*, a video installation and performance which won her the International Award for best artist, was a highlight of the Central Pavilion. For the entire duration of the exhibition, the white-clad artist sat in a dark basement space on a mountain of cow bones, scrubbing them with a wire brush. Whether seen as a cathartic rite or strange exorcism, this performance could immediately be read as a reference to the terrible episodes of ethnic cleansing in the Balkans: a tragic allegory for the fate of Yugoslavia, scarred by civil wars and ethnic conflict, which dealt yet another blow to the twentieth-century myth of the nation state and foreshadowed new localisms and sovereignties. CA

- 1 Letter from Marina Abramović, 14 April 1997
- 2 Letter from Alexander Godschalk on Marina Abramović's behalf to Germano Celant, 19 May 1997
- 3 Marina Abramović  
*Balkan Baroque*, Performance, 4 days, 6 hours  
XLVII Biennale Venice - June, 1997  
Ph: M Stefanoqski  
© Marina Abramović  
Courtesy of the Marina Abramović Archives
- 4 Marina Abramović  
*Balkan Baroque II*, Performance, 4 days, 6 hours  
XLVII Biennale Venice - June, 1997  
© Marina Abramović  
Courtesy of the Marina Abramović Archives
- 5 Marina Abramović  
*Balkan Baroque*, Performance, 4 days, 6 hours  
XLVII Biennale Venice - June, 1997  
Ph: M Stefanoqski  
© Marina Abramović  
Courtesy of the Marina Abramović Archives
- 6 Marina Abramović  
*Balkan Baroque*, Performance, 4 days, 6 hours  
XLVII Biennale Venice - June, 1997  
Ph: Elio Montanari  
© Marina Abramović  
Courtesy of the Marina Abramović Archives
- 7 Marina Abramović  
*Balkan Baroque I*, Performance, 4 days, 6 hours  
XLVII Biennale Venice - June, 1997  
© Marina Abramović  
Courtesy of the Marina Abramović Archives
- 8 Project's proposal for the performance *Balkan Baroque* by Marina Abramović, 1997
- 9 Marina Abramović  
*Balkan Baroque*, Performance, 4 days, 6 hours  
XLVII Biennale Venice - June, 1997  
Ph: Elio Montanari  
© Marina Abramović  
Courtesy of the Marina Abramović Archives

### Monitor

*Making of Balkan Baroque in Venice*, by Ramon Coelho, 1999  
Marina Abramović Archives and LIMA



## 12.4 *dAPERTutto*, Harald Szeemann's first Biennale Arte, 1999

1999 was a year of change: Paolo Baratta's presidency brought major transformations that radically altered the institutional framework of La Biennale di Venezia. Rather than a state-run body frequently affected by political dynamics, it was now a public institution governed by private law, with a smaller board of directors and greater decision-making autonomy. This transformation also ushered in a new exhibition model, which moved away from the multiple commissions of the past in the direction of a single professional curator entrusted to make subjective yet responsible choices that would offer a unique, cohesive vision of contemporary art. That year Baratta appointed Swiss curator Harald Szeemann, who had already worked with La Biennale on *The Bachelor Machines* in 1975 and on *Aperto 80*, to direct the Visual Arts department. Szeemann's exhibition was called *dAPERTutto - APERTO over ALL - APERTO par TOUT - APERTO über ALL* and the title alone revealed his aim: to integrate the *Aperto* section into the main exhibition in a way that would highlight the importance of the work being done by younger generations, welcoming in a range of influences and information from an explosive number of directions, across national and symbolic borders. The exhibition stood out for its curiosity about regions and languages typically neglected by earlier editions. It focused in particular on contemporary Chinese art, which was given equal standing alongside the work of Western artists, and with no distinctions between well-established and emerging talents. The overall impression was of a bubbling ocean of creativity, a global, non-hierarchical, endlessly interconnected landscape, which some critics saw as the definitive "festivalisation" of art as a new form of mass entertainment.

### The 1999 jury

The jury that year was made up of Zdenka Badovinac, Okwui Enwezor, Ida Gianelli, Yuko Hasegawa, and Rosa Martinez. Martinez was also invited, together with Maria de Corral, to curate the 51st International Art Exhibition of 2005, while the Nigerian curator Enwezor returned to Venice as artistic director of Biennale Arte in 2015, after curating important exhibitions around the world such as the 2002 edition of Documenta. Ida Gianelli, who was on the advisory panel in 1997, chaired the jury in 2005, and the following year curated the first Padiglione Italia at the new Tese delle Vergini site, with a presentation by Giuseppe Penone and Francesco Vezzoli. In the 1999 edition, Golden Lions for contemporary art went to Bruce Nauman and Louise Bourgeois, while Doug Aitken, Shirin Neshat, and Cai Guo-Qiang won the International Award, and Lee Bul, Georges Adéagbo, Eija-Liisa Ahtila and Katarzyna Korzyra each won a special mention. The Golden Lion for best national participation went to Italy, which did not have its own full-blown pavilion that time, but was instead taking part in the international exhibition with a sort of virtual pavilion, for which director Szeemann had singled out the work of five young female Italian artists. The winners were Monica Bonvicini, Bruna Esposito, Luisa Lambri, Paola Pivi and Grazia Toderi. CA

### Narrow table 1

1	Interview to Harald Szeemann Alias - Il Manifesto, 29 May 1999
2	Paolo Baratta, 1999. Photo Giorgio Zucchiatti
3	Performance during the opening, 1999. Photo Giorgio Zucchiatti
4	Paolo Baratta and Harald Szeemann in press conference, 1999. Photo Giorgio Zucchiatti
5-7	Giovanna Melandri visits the exhibition with Paolo Baratta and Harald Szeemann, 1999. Photo Giorgio Zucchiatti
8	Minister of Foreign Affairs Lamberto Dini's visit, 1999. Photo Giorgio Zucchiatti
9	Massimo Cacciari and Paolo Baratta, 1999. Photo Giorgio Zucchiatti
10, 21	Lee Bul's Award Ceremony, 1999. Photo Giorgio Zucchiatti
11	Harald Szeemann during the Award Ceremony, 1999. Photo Giorgio Zucchiatti
12	Award Ceremony, 1999. Photo Giorgio Zucchiatti
13, 17	The International Jury during the Award Ceremony, 1999. Photo Giorgio Zucchiatti
14, 15	Award Ceremony, Golden Lion's delivery to Italy for the best national participation, 1999. Photo Giorgio Zucchiatti
16	Okwui Enwezor awards the International Prize "La Biennale di Venezia" to Eija-Liisa Ahtila, 1999. Photo Giorgio Zucchiatti
18	Okwui Enwezor during the Award Ceremony, 1999. Photo Giorgio Zucchiatti
19	International Prize "La Biennale di Venezia" to Cai Guo Qiang, 1999. Photo Giorgio Zucchiatti
20	Honorable Mention to Georges Adéagbo, 1999. Photo Giorgio Zucchiatti
22	Katarzyna Kozyra's Award Ceremony, 1999. Photo Giorgio Zucchiatti

### Narrow table 2

1	Extract from the press kit, text by Harald Szeemann ASAC, Editorial found, Press kits
2-4	<i>The Spinning Oracle of Delphi</i> , James Lee Byars, 1999. Photo Giorgio Zucchiatti
5	<i>Untitled</i> , by Gino De Dominicis, 1999. Photo Giorgio Zucchiatti
6	<i>Three Horizontals</i> , Louise Bourgeois, 1999 <i>Torso</i> , Louise Bourgeois, 1999 <i>Untitled</i> , Louise Bourgeois, 1999. Photo Giorgio Zucchiatti
7	<i>The Cross Table</i> , Ai Weiwei, 1999 <i>72 Standard</i> , Ai Weiwei, 1999. Photo Giorgio Zucchiatti
8	<i>Rat King</i> , Katharina Fritsch, 1999. Photo Giorgio Zucchiatti
9	<i>Solo Scenes</i> , Dieter Roth, 1999. Photo Giorgio Zucchiatti
10	<i>Just For You</i> , Zhang Peili, 1999. Photo Giorgio Zucchiatti
11	<i>Marienerscheinung</i> , Sigmar Polke, 1999. Photo Giorgio Zucchiatti
12	<i>Untitled (periscope)</i> , Martin Kippenberger, 1999 <i>Kippenbinky</i> , Martin Kippenberger, 1999 <i>Sozialkistentransporter</i> , Martin Kippenberger, 1999 <i>Martin, ab in die Ecke und schäm dich</i> , Martin Kippenberger, 1999. Photo Giorgio Zucchiatti
13	<i>Nanostalgia</i> , Sarah Sze, 1999. Photo Giorgio Zucchiatti
14	<i>Mercato delle pulci - messa in vendita di informazioni d'occasione</i> , Wang Du, 1999. Photo Giorgio Zucchiatti
15	<i>TryptychonSchwarzwasser ItryptychonSchwarzwasser</i> , Franz Gertsch, 1999 No. 1998/11/15No. 1998/11/15 No. 1998/11/15 No. 1998/11/15, Fang Lijun, 1999 <i>Untitled</i> , Yang Shaobin, 1999. Photo Giorgio Zucchiatti
16	<i>Untitled</i> , Xie Nanxing, 1999. Photo Giorgio Zucchiatti
17	<i>Untitled</i> , Yang Shaobin, 1999 <i>Untitled 11</i> , Yang Shaobin, 1999. Photo Giorgio Zucchiatti
18	<i>ApproximationRezipientenbedürfniscomaUrUltraUseMaterialMimiMaxi</i> , John Bock, 1999. Photo Giorgio Zucchiatti
19	<i>Il fiore delle 1001 notte</i> , Grazia Toderi, 1999. Photo Giorgio Zucchiatti
20	No. 1998/11/15No. 1998/11/15 No. 1998/11/15 No. 1998/11/15, Fang Lijun, 1999. Photo Giorgio Zucchiatti

- 21 *We Went to Look for Love*, Zhou Tiehai, 1999. Photo Giorgio Zucchiatti
- 22 *The Great White Way Goes Black XI*, Katharina Sieverding, 1999. Photo Giorgio Zucchiatti

### Narrow table 3

- 1 Extract from the press kit, text by Paolo Baratta with the award-winners list, 1999
- 2 *Arsenale*, 1999. Photo Giorgio Zucchiatti
- 3 *Sister in The Sky – Women Pilots in War Duty During WW II*, Simone Aaberg Kaern, 1999. Photo Giorgio Zucchiatti
- 4 *Kastenhaus 1666.14*, Wolfgang Winter and Berthold Hoerbelt, 1999. Photo Giorgio Zucchiatti
- 5 *Everybody Connects to Everybody (Renherenlianxi)*, Yue Minjun, 1999  
*To Raise the Water level in a Fish Pond*, Zhang Huan, 1999. Photo Giorgio Zucchiatti
- 6 *Life*, Yue Minjun, 1999. Photo Giorgio Zucchiatti
- 7 *2 cousins*, Ghada Amer, 1999  
*Untitled #7853*, Ghada Amer, 1999 -  
*Untitled*, Ghada Amer, 1999  
*Untitled (Albers)*, Ghada Amer, 1999. Photo Giorgio Zucchiatti
- 8 *Electricearth*, Doug Aitken, 1999. Photo Giorgio Zucchiatti
- 9,10 *Pentecost*, Tim Hawkinson, 1999. Photo Giorgio Zucchiatti
- 11 *Nature Series N° 10*, Liang Shaoji, 1999. Photo Giorgio Zucchiatti
- 12 *The Dream of China*, Wang Jin, 1999  
*To Marry a Mule*, Wang Jin, 1999. Photo Giorgio Zucchiatti
- 13 *Untitled (Soli-Trac Series)*, Luisa Lambri, 1999. Photo Giorgio Zucchiatti
- 14 *Proyecto Para Estudiomóvil Para un Artista del Nuevomilenio*, Ana Laura Aláez, 1999. Photo Giorgio Zucchiatti
- 15 *I Believe in the Skin of Things as in that of the Women*, Monica Bonvicini, 1999. Photo Giorgio Zucchiatti
- 16 *Mama Vece, Videolounge*, di Costa Vece, 1999. Photo Giorgio Zucchiatti
- 17 *Staging*, Corderie dell’Arsenale, 1999. Photo Giorgio Zucchiatti
- 18-20 *Aereo*, Paola Pivi, 1999. Photo Giorgio Zucchiatti
- 21 *Hell Gate*, Chris Burden, 1999. Photo Giorgio Zucchiatti
- 22 *Cities On The Move - Bottari Truck In Exile (Dedicated to the Kosovo Refugees)*, Soo-Ja Kim, 1999. Photo Giorgio Zucchiatti

### Narrow table 4

- 1 **Ipad**  
48th International Art Exhibition, Harald Szeemann’s speech, Art’e, RAI, 1999
- 2,3 Exhibition staging, 1999. Photo Giorgio Zucchiatti
- 4 Cai Guo Qiang, 1999. Photo Giorgio Zucchiatti
- 5 Audience interacting with the artwork *Jue Chang/Fifty Strokes to each (maxime bouddhiste)* by Chen Zhen, 1999. Photo Giorgio Zucchiatti
- 6 *Cement Truck*, Wim Delvoye, 1999. Photo Giorgio Zucchiatti
- 7, 8 *Proposition*, Paul McCarthy & Jason Rhoades, 1999. Photo Giorgio Zucchiatti
- 9, 10 *Flugplatz Welt*, Thomas Hirschhorn, 1999. Photo Giorgio Zucchiatti
- 11, 12 *Solo Comprendo lo Que Pienso Cuando lo Dibujo*, Kcho, 1999. Photo Giorgio Zucchiatti
- 13, 14 *Jue Chang/Fifty Strokes to each (maxime bouddhiste)*, Chen Zhen, 1999. Photo Giorgio Zucchiatti
- 15 *Cyborg W1-W4*, Lee Bul, 1999. Photo Giorgio Zucchiatti
- 16, 17, 18 *Venice – Rent Collecting Courtyard*, Cai Guo Qiang, 1999. Photo Giorgio Zucchiatti
- 19, 20 *Nothing*, Pipilotti Rist, 1999. Photo Giorgio Zucchiatti
- 21, 22 *Fachiro*, Maurizio Cattelan, 1999. Photo Giorgio Zucchiatti
- 23, 24 *Aquarell e Madrepatria*, Bruna Esposito, 1999. Photo Giorgio Zucchiatti

## 12.5 Carolyn Carlson and the birth of Biennale Danza, 1999

Finnish American dancer and choreographer Carolyn Carlson (1943-) turns up in the history of La Biennale on many occasions. Her first appearance there in 1968 was in Alwin Nikolais’s “total artwork” *Imago*. In the 1980s she directed Teatro Danza La Fenice; this modern research group was the brainchild of Teatro La Fenice artistic director Italo Gomez, a firm champion of an entirely new approach to dance, since opera theatres traditionally work with a permanent ballet company. In 1999, this unique “imprinting” led to her launch La Biennale’s new Dance department at the invitation of President Paolo Baratta, who supported her innovative mission to explore the poetry of movement, foster personal and collective creativity, and train the next generation – as one can see from Accademia Isola Danza, which welcomed many young talents from around the world.

In 1975 France named her étoile choreographer (a new title) of the Opéra de Paris, where she headed the GRTOP ensemble. It was in France and Italy that her spiritual approach to the body and nature helped spread a form of contemporary dance fuelled by visionary improvisation. Her vibrantly imaginative approach has been a powerful inspiration to many performers and choreographers, starting with the Sosta Palmizi company founded in 1985 under her influence, which spearheaded the new current in Italian dance. She launched her cycle of work for La Biennale in 1999 with *Parabola*, created for and with her pupils at Teatro Verde, a restored open-air theatre space on the island of San Giorgio. She also presented *Il vuoto nell’acqua* and *Solo Donna* with many leading figures from the international dance world: Malou Airaudo, Mui Cheuk-Yin, Carla Fracci, Raffaella Giordano, Nina Hyvarinen, Sabine Kupferberg, Eva La Yerbabuena, Susanne Linke, Barbara Martinini, Madhavi Mugdal, Marie-Claude Pietragalla, Helena Pikon, Talia Posner, Caterina Sagna, Anna Sariola, Rina Shenfeld, Alarmel Valli, Elsa Wolliaaston, Kazuo Ohno in *La Argentina*, and Marie Chouinard, now the artistic director of La Biennale’s Dance department.

- 1 *La nuova Biennale ricomincia da tre*  
Il Gazzettino, 18 July 1998, Valeria Lipparini
- 2 *La Biennale cambia. Con tre nuovi direttori*  
Corriere della Sera, 18 July 1998, Paolo Conti
- 3 *‘Solo donna’ di Carolyn Carlson*  
Danza & Danza, September - October 1999, Marinella Guatterini
- 4 *Basta con l’occasione rara, ora si costruisce la stabilità*  
Giornale dello spettacolo, 3 September 1999, interview curated by Andrea Porcheddu
- 5 Letter from Carolyn Carlson to Alfredo Zanolta, 5 August 1999
- 6 **Ipad**  
Video *Parabola*, di Carolyn Carlson e Gianni de Luigi, 1999
- 7 *Parabola*. Evento originale di Carolyn Carlson e Gianni De Luigi per la riapertura del Teatro Verde, 1999
- 8 Fax from Carolyn Carlson to Paolo Baratta, 23 April 1999
- 9, 10, 12-14 *Parabola*, opening night, Teatro Verde, 30 July 1999. Photo Giorgio Zucchiatti
- 11 Introduction for the Accademia Isola Danza, Carolyn Carlson, 1999

## 12.6A 5th International Architecture Exhibition, curated by Francesco Dal Co, 1991

In 1988, during the second of Paolo Portoghesi's four-year terms as artistic director, Francesco Dal Co was appointed curator of the Architecture section. The fifth International Architecture Exhibition was held in 1991, and brought together Dal Co's work and initiatives over the previous four years. Convinced of the need to take the Biennale in an international direction, Dal Co brought in a new feature, modelling this edition after the Biennale Arte format and inviting over thirty-five countries to take part. The national pavilion proposals included Austria with work from Coop Himmelb(l)au, the United States with projects by Peter Eisenman and Frank O. Gehry, Switzerland with a Herzog & de Meuron retrospective and Norway with Sverre Fehn. In the Central Pavilion, Dal Co presented forty Italian architects "for the 1990s", including Gae Aulenti, Massimiliano Fuksas, Aldo Aymonino, Giancarlo De Carlo, Renzo Piano, Luciano Semerani and Ettore Sottsass.

Two episodes stood out in this edition: the construction of the Padiglione del Libro (Book Pavilion) designed by James Stirling on the avenue leading into the Giardini, and the Corderie exhibition of work from forty-three architecture schools all over the world. This marked the birth of the Premio Venezia award for schools, selected from a range of cultural, social, and historical contexts with an effort to include those marginalised from the hubs of international architectural debate. Through this initiative the Biennale created a place for dialogue and exchange, periodically turning the Corderie into a sort of temporary workshop for young architects from around the globe.

Dal Co also reiterated the importance of interaction between the Biennale and Venice, as one can see from the three competitions held during his term from 1988 onwards. They focused, respectively, on the redesign of the Central Pavilion in the Giardini (won by Francesco Cellini), the renovation of the Palazzo del Cinema on the Lido (won by Rafael Moneo), and the refurbishment of Piazzale Roma as "A Gateway to Venice", open to architects and engineers from all over the world (won by Jeremy Dixon and Edward Jones). Contrary to La Biennale's hopes, none of these proposals was ever actually carried out – unlike Stirling's Padiglione del Libro, which is considered one of the most enduring results of this edition. Massimo Scolari's Aliante installation, which was then sited by the Fondamenta della Tana as an outdoor sign of the architecture school exhibition, also survived and is now at IUAV University of Venice's Cotonificio building in Santa Marta. MCC

1 Vittorio Gregotti, Aldo Rossi and Paolo Portoghesi, 1991

2 The Fifth International Architecture Exhibition, 1991

3 James Stirling, Francesco Dal Co and Paolo Portoghesi, 1991

4 Venice prize: forty-three architecture schools in the world, 1991

5 List of the Italian universities invited to the Venice Prize, s.d.

6 Book pavilion, James Stirling at the Giardini, 1991

7 *Padiglione del libro Electa della Biennale di Venezia* di J. Stirling, M. Wilford and associates with T. Muirhead, 1991

8 *Aliante*, Massimo Scolari, 1991

9 *Tutta la Biennale*  
Casa Vogue n. 233 1991, Laura Maggi

10 Entrance to the Giardini della Biennale, 1991

11 *Peter Eisenman & Frank Gehry*, 1991

12 *Brazil: Ruy Ohtake*, Fernando Peixoto, 1991

13 *Ishii Kazuhiro, Isozaki Arata, Maki Fumihiko, Sakata Seizo, Takamatsu Shin*, 1991

14 *MAPXII (MARHI)*, 1991

15 *13 Austrian positions*, 1991

## 12.6B 6th International Architecture Exhibition, *Sensing the Future: The Architect as Seismograph*, curated by Hans Hollein, 1996

The sixth edition of Biennale Architettura was curated for the first time by a figure of international standing, Hans Hollein. This Austrian architect continued Dal Co's approach and followed the Biennale Arte model in his organisation of the event, hosting national contributions. The main exhibition set up at the Central Pavilion of the Giardini, *Sensing the Future: The Architect as Seismograph*, explored how architects can capture underground movements in the present and project them into the future. Hollein believed that in the 1990s architects no longer belonged to schools or movements but were autonomous figures, unfettered by classifications. As a result of phenomena that had yet to be taken into real consideration, such as communication systems and new technologies, architects were changing the key places in cities, challenging the traditional idea of urban space inherited from the past.

Around seventy architects were invited to exhibit projects considered especially significant, worthy of passing down to future generations. Designs by the most eminent architects on the international scene were exhibited in the Central Pavilion, including Frank O. Gehry with his Bilbao Guggenheim project, Tadao Ando, Jean Nouvel, Renzo Piano, Zaha Hadid, Coop Himmelb(l)au, Peter Eisenman, Norman Foster, Herzog & de Meuron, Arata Isozaki, Toyo Ito, Philippe Starck, Jørn Utzon, Álvaro Siza Vieira, Massimiliano Fuksas, Rem Koolhaas and Rafael Moneo.

Alongside globally recognised architects, Hollein organised the exhibition *Emerging Voices*, which displayed the work of promising young architects from all over the world, such as Odile Decq, Liz Diller with Ricardo Scofidio, Peter Zumthor, Ben van Berkel, and Kazuyo Sejima. The Central Pavilion was also the site of a retrospective titled *Radicals*, focusing on the most radical urban architecture experiments from the late 1950s to the early 1960s. The Italian section, curated by Marino Folin, was presented in the Central Pavilion with large-scale facades and designs by the generation of young architects then in their thirties. A photographic exhibition – the result of a collaboration between photographer Gabriele Basilico and architect Stefano Boeri – examined the urban and natural landscape of Italy.

In 1996 a career Golden Lion was also created for the Biennale Architettura. In its first edition it was awarded to

three great twentieth-century architects: Ignazio Gardella, Philip Johnson and Oscar Niemeyer. The Golden Lion for best national participation went to Japan that year while the awards for best project went to Odile Decq and Benoît Cornette, Juha Kaakko, Ilkka Laine, Kimmo Liimatainen, Jari Tirkkonen and Enric Miralles Moya. Three figures who had made important contributions to architecture in very different capacities were awarded special Osella awards: Pascal Maragall, mayor of Barcelona, for his architecture and town planning initiatives, Wim Wenders for his attention to architecture in media and film, and Gabriele Basilico for his photographic work. MCC

- 1 *Sensing the Future: The Architect as Seismograph* leaflet, 1996
- 2 Extract from the press kit of *Sensing the Future: The Architect as Seismograph*, text by Hans Hollein, 12 July 1996
- 3 *Che cos'è una Biennale di architettura?* Dietmar Steiner's interview with Hans Hollein, *Domus*, n. 788, 1993
- 4 Facade of the Italian pavilion, 1996
- 5 Overall view of the central hall of the Italian pavilion, 1996
- 6 *Rimini-San Marino*, Gabriele Basilico, 1996
- 7 Map for the *Paesaggio italiano* section, 1996
- 8 *Firenze-Pistoia*, Gabriele Basilico, 1996
- 9 Project *Victoria & Albert Museum*, Zaha Hadid, 1996
- 10 Extract from the press kit of *Sensing the Future*, list of the participants in the *Emerging Voices* section, 1996
- 11 Project by Odile Decq & Benoit Cornette for the *Emerging Voices* section, 1996
- 12 Odile Decq with the Golden Lion for the best project in the exhibition, 1996
- 13, 18 Project by Kazuko Sejima for the *Emerging Voices* section, 1996
- 14 Letter from Hans Hollein to Odile Decq & Benoit Cornette, 31 May 1996
- 15 Project *Musicon Bremen* by Nasrine Seraji, 1996
- 16 Project by Diller + Scofidio for the *Emerging Voices* section, 1996
- 17 Project *Survival kit for ghost*, Elsa Prochazka, 1996

## 12.7 The history of the Giardini's national pavilions

The first International Art Exhibition of the City of Venice was held at the Giardini di Castello in 1895. At that time the only exhibition space was Palazzo dell'Esposizione, which changed its name frequently in the twentieth century (Palazzo Pro Arte, Padiglione Italia, Padiglione Centrale) and hosted the main exhibitions as well as the Italian one. In 1907 the first national pavilion, Belgium's, was built in the Palazzo dell'Esposizione area, followed by those of Germany, Great Britain and Hungary in 1909, France and Holland in 1912, and Russia in 1914. In 1914, the year World War One broke out, the Giardini map reflected the great powers that were soon to become pivotal players in the diplomatic and political games of twentieth-century Europe. The construction of the national pavilions carried on the spirit of the great universal exhibitions of the late nineteenth century, expressing the desire to create an open international dialogue, and to measure Italian art – which in the first decades of the twentieth century was housed in the Palazzo dell'Esposizione – against that of other countries. In the 1930s La Biennale's secretary general, Antonio Maraini, grasped the importance of this international aspect and sped up the building of other

pavilions: the United States in 1930, Denmark in 1932, and Austria and Greece in 1934. Maraini dreamed of a Biennale that would be a "Geneva of the arts", a United Nations of Art where each country would bring its finest work to Venice. By the outbreak of World War Two there were seventeen pavilions in the Giardini. In the decades that followed new pavilions were built, expanding participation to include South American countries such as Venezuela in 1954, Uruguay in 1960, and Brazil in 1964. From the East, Japan arrived in 1956, Australia in 1987 and the Republic of Korea in 1995. By 1995 there were twenty-eight pavilions (although more countries than this were actually taking part, since some pavilions were shared by several nations). By 1986 all available space at the Giardini had been used up, and many nations were hosted in the Arsenale and other sites throughout the city. At the 2019 edition of the Biennale Arte there were eighty-eight national pavilions.

The Biennale's pavilions not only offer an overview of the art coming out of different countries, but show a complex mosaic of the ideologies, diplomatic power balances, and geopolitical and colonial dynamics underlying twentieth-century history. In over one hundred years of history, La Biennale has seen world wars, the emergence and disappearance of states – Israel, the two Germanies reunified, the Soviet Union and the former Yugoslavia – and other fluctuating fortunes. Pavilions have changed names and been closed in protest, boycotted and even occupied by other countries. Their architecture has been modernised to reflect new aspirations or hide embarrassing skeletons in the closet. These transformations have reflected changes in the very concept of the nation state, which has continued to evolve since the 1990s and in the new millennium, with the birth of a united Europe.

Okwui Enwezor, the Nigerian curator who directed the Biennale Arte 2015, made an in-depth study of the history of the pavilions, which was published in the *All the World's Futures* catalogue as the essay "Exploding Gardens": "More than just a fairground for an exhibition, the Giardini represents, in miniature, a scene of processes of national determination and social upheaval. [...] The garden is a molecular landscape of accreted fragments, a topography of atomized residue".

Some of the buildings in the Giardini are significant examples of modern architecture, like the Austrian pavilion by Josef Hoffmann (1934), the Finnish pavilion by Alvar Aalto (1956) the Dutch pavilion by Gerrit Rietveld (1953), or the Nordic pavilion by Sverre Fehn (1962). Alongside them we find the work of Italian architects, such as Carlo Scarpa's Venezuelan pavilion (1954) and the BBPR group's Canadian pavilion (1958). The national pavilion buildings are all owned either by the countries themselves or by the City of Venice, and are managed by the respective governments or by foundations responsible for building maintenance and national participation in the exhibition.

In the global panorama of biennales, the national pavilion formula is unique and exclusive to La Biennale di Venezia. Over the years this model has been criticised and accused of being anachronistic, but it has been defended with equal fervour by those who consider it an irreplaceable tool for the dissemination of art and culture. CA



# ROOM 13

## THE CENTRAL PAVILION SINCE 1895

In 1887 Venice hosted the Esposizione Nazionale Artistica (National Artistic Exposition), a major event that had already been held in other Italian cities to bolster the new national identity. The event was eagerly anticipated by the local government, which hoped it would boost the Venetian economy. Large buildings were therefore constructed on the Giardini di Castello shore, but ultimately the exhibition left a large hole in the city budget. Despite this the event was considered a dress rehearsal for the first Biennale, held in 1895. In 1894 the old riding school designed by Tommaso Meduna was partially knocked down. Over the years it had become a sort of zoo, its main attraction being a gift from the royal family to the children of Venice: Toni the elephant, also known as “the prisoner in the Giardini”. A single building was to be constructed incorporating some rooms from the former structure, like its main hall (which became the concert hall). The project was overseen by the engineer Enrico Trevisanato, while the facade was designed by the painters Bartolomeo Bezzi and Mario De Maria. Their temple of art (called “Pro Arte”) was inspired by Neoclassical architecture and especially that of Munich, home to the first Secession. In 1914 the facade was redone in Art Nouveau style by architect Guido Cirilli, who removed the colonnade, adding decorative elements and two elegant little towers on the sides. In 1928 Antonio Maraini decided to have the towers removed, and in 1932 the architect Duilio Torres was commissioned to remodel the central building entirely. The first design for the new facade dates to 1931; though the effect was quite different, it simply modified the pre-existing one by Cirilli and added four plain columns holding up the linear pediment. Above the colonnade, topped by a jutting cornice, the word ITALIA was placed between sculptor Tony Lucarda’s two square reliefs of St Mark’s lion and the imperial Roman eagle. The new facade was made of beton concrete and work was completed in just two months, from February to April 1932. As for the renovation of the interior, Torres aimed for a

clean look, choosing pale colours for the walls and attempting to create sightlines between the spaces, in a tidy string of rooms. Careful attention was paid to the arrangement of the works, “not square metres of paintings, but a spacious, serene exhibition, of almost impossible logic and symmetry”. In 1938 the facade was adorned with two large frescoes on either side of the doors, allegories of Venice and Rome by Antonio Santagata and Franco Gentilini respectively. In 1940 two large sculptures were added: allegories of painting and sculpture by Napoleone Martinuzzi and Umberto Baglioni, which are still in the Giardini. In 1968 the architect Carlo Scarpa covered over the Fascist facade with geometric elements made from various materials, effectively deconstructing Torres’ straightforward design with a cladding that remained in place throughout the 1970s. In the same year, Louis Kahn also created designs for the renovation of the Palazzo dell’Esposizione, which were never carried out. VP

## The Giardini before the Pavilion, 1887

1	Letter from the organizer Executive Committee to the City Hall of Venice, 10 January 1886
2	<i>I giardini pubblici prima della Biennale</i> , drawing by Raffaele Mainella L'Esposizione Artistica Nazionale Illustrata - Venezia n. 1, 27 March 1887
3	<i>R. D'Aronco: decorazioni esterne dell'esposizione</i> , drawing by Giuseppe Vizzotto L'Esposizione Artistica Nazionale Illustrata - Venezia n. 3, 10 April 1887
4	Letter from Pietro Fragiaco to the Committee, 27 February 1887
5	<i>Venise Exposition Nationale Artistique 1887</i> leaflet
6	Invitation, 1887
7	Letter from Lorenzo Tiepolo about the constitution of the Executive Committee, 28 June 1886
8	Declaration card of Giovanni Segantini's artworks, 11 October 1886
9	Declaration card of Ettore De Maria Bergler's artworks, 13 December 1886
10	Declaration card of Giacomo Grosso's artworks, 13 December 1886
11	Tender specifications for the construction contract of a building in bonding and iron and a brick-built Café - Restaurant, to be built in the Giardini Pubblici di Venezia, for use by the Esposizione Nazionale Artistica of 1887
12	Letter of protest from the artists to the Executive Committee, 1887
13	<i>Pianta del palazzo dell'esposizione nazionale artistica di Venezia 1887 / R. D'Aronco: lo chalet degli artisti</i> , drawing by Mainardo Pagani, L'Esposizione Artistica Nazionale Illustrata - Venezia n. 4, 17 April 1887
14	Letter from Plinio Nomellini to the Executive Committee, 13 July 1887
15	Letter from Pompeo Mariani to the Executive Committee, 1887

## The Central Pavilion, 1895

1	Construction works at the Central Pavilion, 24 January 1895
2	Facade of the Central Pavilion, 1895
3	Facade, main entrance, 1895
4	<i>Facade of the Palazzo dell'Esposizione of La Biennale di Venezia</i> , 1895 by Bartolomeo Bezzi and Mario de Maria, pencil and watercolours on paper, 58.4x90 cm
5	Map of the Central Pavilion, 1895
6	The Giardini
7	Entrance to the Giardini
8	Plan of the Central Pavilion, 1897
9	Facade of the Central Pavilion, 1907
10	The stands at the entrance of the exhibition designed by Raffaele Mainella, 1907
11	Facade of the Central Pavilion, 1914
12	Facade of the Central Pavilion, 1930. Photo Studio Giacomelli
13-15	Interior of the Café, Brenno del Giudice, 1928
16	Entrance to the Giardini, ticket office. Photo Cav. P. Fiorentini
17	<i>Plan and elevation for the café in Giardino</i> , Brenno del Giudice, 1928 pencil and colour pencils on paper, 51.5x35 cm
18	Map of the Central Pavilion, 1928
19	Facade of the Central Pavilion, architect Duilio Torres, 1932
20	Facade of the Central Pavilion, 1938
21	Facade of the Central Pavilion, 1940. Photo Studio Giacomelli
22	Facade of the Central Pavilion, 1950
23	<i>Project for a new entrance to the Giardini della Biennale at the new border's limits</i> , Carlo Scarpa, 1952. China ink on paper, 60x103 cm
24	Letter from Rodolfo Pallucchini to Carlo Scarpa, 31 May 1951
25	Letter from Rodolfo Pallucchini to Carlo Scarpa, 6 June 1952
26	Lettera from Rodolfo Pallucchini to Carlo Scarpa, 20 June 1952
27	The Carlo Scarpa's courtyard, 1952. Photo Studio Giacomelli
28	Carlo Scarpa, architectural intervention on the facade of the Central Pavilion, 1968. Photo Studio Ferruzzi

29	Letter from Carlo Scarpa to Rodolfo Pallucchini, 31 May 1951
30	Letter from Carlo Scarpa to Rodolfo Pallucchini, 30 July 1952
31	Letter to Giovanni Piccini, 19 August 1952
32	Carlo Scarpa, adaptation project of the Italian pavilion, 1963
33	Carlo Scarpa, portrait
34	Carlo Scarpa, installation at the entrance to the Central Pavilion, 1962
35	Carlo Scarpa with the audience
36	<i>Ambiente</i> by Carlo Scarpa for the <i>Linee della ricerca: dall'informale alle nuove strutture</i> exhibition, 1968
37	Carlo Scarpa, Luigi Nono, Emilio Vedova during the protest at the Giardini, 1968

# CENTRAL PAVILION

## ROOM 1

**The Film Festival, 1932-1939**

## ROOM 2A

**The Biennale during Fascism 1928 - 1945**

## ROOM 2B

**The Cold War and the New World Order 1947 -1964**

## ROOM 3

**1968: a year of protests and new ideals**

## ROOM 4

**The 1970s: interdisciplinary and political work**

## ROOM 5

*Freedom for Chile, 1974*

## ROOM 6

**Sofija Gubajdulina, applied music and absolute music**

## ROOM 7

**The Biennale of Dissent, 1977**

## ROOM 8

**The First International Architecture Exhibition and Postmodernism, 1980**

## ROOM 9

**La Biennale and the Society of the spectacle**

## GIARDINO SCARPA

**Tan Dun, traditional music and tecnologia**

## ROOM 12

**The 1990s: from Nation-States to a Global Biennale**

## ROOM 13

**Central Pavilion since 1895**





# La Biennale di Venezia

## ORGANISATIONAL STRUCTURE

### Director General

Andrea Del Mercato

### Artistic Directors

Cecilia Alemani - Art  
Alberto Barbera - Cinema  
Marie Chouinard - Dance  
Ivan Fedele - Music  
Antonio Latella - Theatre  
Hashim Sarkis - Architecture

### Artistic Directors' Staff

Marta Papini (Art)  
Giuseppe Ghigi (Cinema)  
Elisa Guzzo Vaccarino (Dance)  
Cesare Fertonani (Music)  
Federico Bellini (Theatre)

### Exhibition Design

Formafantasma

### HISTORICAL ARCHIVES OF LA BIENNALE DI VENEZIA

**Executive /  
Head of Organisation**  
Debora Rossi

### Historical Archives

Giovanna Bottaro  
Michela Campagnolo  
Maria Elena Cazzaro  
Marica Gallina  
Michele Mangione  
Adriana Rosaria Scalise  
Alice Scandiuzzi

### Library

Valentina Da Tos  
Erica De Luigi  
Valentina Greggio  
Manuela Momentè  
Annalisa Montesi  
Elena Oselladore

### Collaborators for The Disquieted Muses. When La Biennale di Venezia Meets History

Lia Durante  
Andrea Avezzi  
Valentina Campana  
Giulia Campana  
Liv Ingrid Cuniberti  
Francesco di Cesare  
Fabrizia Farragina  
Matteo Giannasi  
Enzo Magris  
Vittorio Pajusco  
Lucia Toso  
Elisabetta Vitullo

### CENTRAL SERVICES

### LEGAL AND INSTITUTIONAL AFFAIRS, HUMAN RESOURCES AND DEPUTY

### Director

Debora Rossi

### Legal and Institutional Affairs

Martina Ballarin

### Human Resurces

Graziano Carrer  
Claudia Capodiferro  
Luca Carta  
Giovanni Drudi  
Antonella Sfriso  
Alessia Viviani  
Loris Zennaro  
Rossella Zulian

### ADMINISTRATION, FINANCE, MANAGEMENT SUPERVISION AND SPONSORSHIP, PROMOTION

### Director

Valentina Borsato

### Administration, Finance, Management Supervision

Bruna Gabbiano  
Elia Canal  
Marco Caruso  
Martina Fiori  
Gregorio Granati  
Elisa Meggiato  
Emanuela Pelliccioli  
Cristina Sartorel  
Sara Vianello

### Sponsorship

Paola Pavan

### Promotion

Caterina Castellani  
Lucia De Manincor  
Elisabetta Fiorese  
Stefania Guglielmo  
Emanuela Padoan  
Marta Plevani

### SECRETARIATS

### General Secretariat

Caterina Boniollo  
Maria Cristina Cinti  
Elisabetta Mistri  
Chiara Rossi  
Lucrezia Stocco

### Protocol Office

Francesca Boglietti  
Lara De Bellis  
Laura Lerro

### Biennale College

### Secretariat

Giacinta Maria Dalla Pietà

### TECHNICAL AND LOGISTICAL SERVICES

### Director

Cristiano Frizzele

### Exhibition Design, Events and Live Performance

Massimiliano Bigarello  
Cinzia Bernardi  
Alessandra  
Durand de la Penne  
Jessica Giassi  
Valentina Malossi  
Sandra Montagner

### Facility Management

Marco Bagaggia  
Giulio Cantagalli  
Francesco Paolo Di Cui  
Piero Novello  
Maurizio Urso

### Information Technology

Andrea Bonaldo  
Michele Schiavon  
Leonardo Viale  
Jacopo Zanchi

### SPECIAL PROJECTS, PROMOTION OF VENUES

### Director

Pina Maueri

### Special Projects

Arianna Laurenzi  
Valentina Baldessari  
Davide Ferrante  
Elisabetta Parmesan

### Promotion of Venues

Nicola Bon  
Cristina Graziussi  
Alessia Rosada

### PURCHASING, PROCUREMENT AND ASSETS

### Director

Fabio Pacifico

### Purchasing and Procurement

Silvia Gatto  
Silvia Bruni  
Annamaria Colonna  
Cristiana Scavone

### Hospitality

Linda Baldan  
Jasna Zoranovic  
Donato Zotta

### Assets

Maurizio Celoni  
Antonio Fantinelli

### INSTITUTIONAL AND CINEMA PRESS OFFICE

### Head

Paolo Lughì

Michela Lazzarin  
Fiorella Tagliapietra

### EDITORIAL ACTIVITIES AND WEB

### Head

Flavia Fossa Margutti

Giovanni Alberti

Roberta Fontanin  
Giuliana Fusco  
Nicola Monaco  
Maddalena Pietragnoli

### VISUAL ARTS - ARCHITECTURE DEPARTMENT

### Executive /

**Head of Organisation**  
Joern Brandmeyer

Marina Bertaggia  
Stefania Fabris  
Stefania Guerra  
Francesca Aloisia Montorio  
Luigi Ricciari  
Micol Saleri  
Paolo Scibelli

### VISUAL ARTS - ARCHITECTURE PRESS OFFICE

### Head

Maria Cristiana Costanzo

Francesca Buccaro  
Claudia Gioia

### CINEMA DEPARTMENT

### Director General

Andrea Del Mercato

### Secretariat

Mariachiara Manci  
Alessandro Mezzalana

### Venice International Film Festival

### Programming Office

Giulia Carbone  
Silvia Menegazzi  
Daniela Persi

### Industry-Cinema

### Accreditations

Flavia Lo Mastro

### Biennale College Cinema

Valentina Bellomo

### DANCE, THEATRE, MUSIC DEPARTMENT

### Executive /

**Head of Organisation**  
Francesca Benvenuti

### Secretariat

Veronica  
Mozzetti Monterumici

### Programming and Production

Federica Colella  
Michela Mason  
Maya Romanelli

### DANCE, THEATRE, MUSIC PRESS OFFICE

### Head

Emanuela Caldirola

**LA BIENNALE DI VENEZIA  
THE DISQUIETED MUSES. WHEN LA BIENNALE DI VENEZIA MEETS HISTORY****Info Public**

Venice, Central Pavilion, Giardini della Biennale  
 29 August > 8 December 2020  
 Closed on Mondays (except 31 August, 7 September, 2 November, 7 December)  
 29 August > 5 October: 11 a.m. – 7 p.m. (last admission: 6.30 p.m.)  
 6 October > 8 December: 10 a.m. – 6 p.m. (last admission: 5.30 p.m.)

**TICKETS**

Tickets available online only, on [www.labiennale.org](http://www.labiennale.org)  
 Regular ticket € 12  
 Students € 8  
 Adult groups € 10 (min. 10 persons)  
 Tickets are strictly personal and non-transferable  
 Please choose the time of your access to the Exhibition during ticket purchase

**FREE ADMISSION**

Child until 6 y.o. (included), adults accompanying disabled visitors holding a disability ID  
 Free tickets can be requested to [promozione@labiennale.org](mailto:promozione@labiennale.org)  
 at least 3 days before the visit day

**EDUCATIONAL – GUIDED TOURS WITH RESERVATION  
FOR ORGANISED GROUPS**

Available in Italian, English, French, Spanish, and German  
 Reservation required at least 7 days before the visit date,  
 by filling out the form on [www.labiennale.org](http://www.labiennale.org)  
 Average duration 1h.  
 Admission ticket is not included and must be purchased separately  
 Available from Tuesday until Sunday, from 29 August until 8 December  
 and on special opening Mondays (31 August, 7 September, 2 November, 7 December)

**Prices\***

Adults € 40  
 Students (High-schools/Universities) € 25  
 \* prices are per group (max 20 participants per group)

**GUIDED TOURS AT STATED TIMES (for individual visitors)**

Available on Saturdays and Sundays in Italian and English, from 29 August until 8 December  
 Reservation required, at least 7 days before the visit date.  
 Average duration 1h.

**Time**

Italian: 11 a.m.  
 English: 2 p.m.

**Price € 5\***

\* Admission ticket is not included and must be purchased separately

**SERVICES FOR VISITORS**

Bar, restaurants, bookshop, toilette with changing table  
 No cloakroom available  
 Animals are not admitted to the Exhibition venue

**TICKETS AND GUIDED TOURS INFORMATION**

Ticket purchase and guided tour reservation available online: [www.labiennale.org](http://www.labiennale.org)

**EDUCATION AND PROMOTION OFFICE**

[promozione@labiennale.org](mailto:promozione@labiennale.org)  
 Ph. +39 041 5218 828  
 (Mon>Fri 10 a.m.-1.30 p.m. and 2.30 p.m. – 5.30 p.m.)

**HOW TO REACH THE EXHIBITION VENUES**

From Venice Bus Station (Piazzale Roma) and from Railway Station (Venezia S. Lucia):  
 to Giardini: ACTV lines 1, 2, 4.1, 5.1, (6 only from Piazzale Roma)

**PLAN YOUR VISIT**

**NOTICE: to comply with the health emergency protocols required for cultural activities, visitors are requested to come with face masks, and to respect their chosen visit day and time slot.**

**Visitors are kindly asked to wear face masks inside the Central Pavilion and to keep a one-metre safety distance from other people during their visit.**

Marina Abramovic  
 Rita Donough  
 Gregorio Gonnella  
 Hans Haacke  
 Dodie Kazanjian  
 Nigel McKernaghan  
 Stefano Mutu  
 Clarissa Ricci  
 Pietro Rigolo

Marco Borghi  
 Enrico Bufalini  
 Annalisa Ciampi  
 Carla Consalvi  
 Natalie Giacobino  
 Gabriella Macchiarulo  
 Cristiano Migliorelli  
 Gianluca Picciotti  
 Roland Sejko  
 Fabiola Solvi  
 Grazina Subelyte  
 Karole Vail

**La Biennale di Venezia****Editorial Activities and Web****Head**

Flavia Fossa Margutti

**Texts by**

Cecilia Alemani CA  
 Federico Bellini FB  
 Maria Cristina Costanzo MCC  
 Cesare Fertonani CF  
 Giuseppe Ghigi GG  
 Elisa Guzzo Vaccarino EGV  
 Vittorio Pajusco VP  
 Marta Papini MP  
 Debora Rossi DR

**Redaction**

La Biennale di Venezia  
*collaborator* Lucia Toso

**Graphic Design and Layout**

La Biennale di Venezia  
 Nicola Monaco, Riccardo Cavallaro  
*with the collaboration of*  
 Ornella Mogno and Francesca Pavanel

**Translations**

INTRAS Congressi Srl  
 Isabelle Johnson

**English Editing**

Johanna Bishop

First Edition: August 2020

© La Biennale di Venezia 2020

All Rights Reserved

under international copyright conventions.  
 Print: L'Artegrafica di Zaia P., Casale sul Sile (TV)

No part of this book may be reproduced or utilised in any form or by any means, electronic or mechanical, including photocopying, recording or any information storage and retrieval system, without permission in writing from the publisher.

**29.08 – 4.10 h. 11 – 19**  
**6.10 – 8.12 h. 10 – 18**  
**closed on mondays**

**promozione@labiennale.org**  
**#BiennaleArchivio**  
**#MuseInquiete**  
**labiennale.org**

